



Meubles de Qualité à Prix Abordable
Affordable Quality Home Furniture

BUREAU 60"L MÉTAL ARGENT / NOYER HOLLOW-CORE
WALNUT HOLLOW-CORE / SILVER METAL 60"L OFFICE DESK

I 7083

INSTRUCTIONS D'ASSEMBLAGE
ASSEMBLY INSTRUCTIONS

MONARCH SPECIALTIES INC.



**POUR DE L'ASSISTANCE OU POUR COMMANDER
DES PIÈCES CONTACTEZ NOTRE DÉPARTEMENT
DE SERVICE À LA CLIENTÈLE.**

**FOR ASSISTANCE OR TO ORDER PARTS
CONTACT OUR CUSTOMER SERVICE DEPARTMENT**

WWW.MONARCHSERVICE.COM



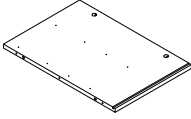
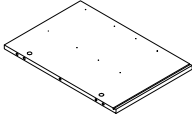
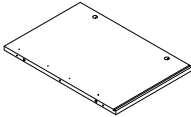
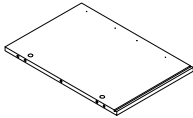
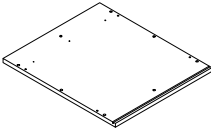
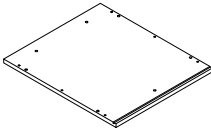
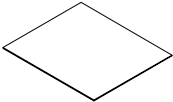
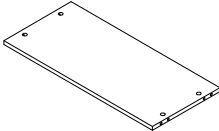
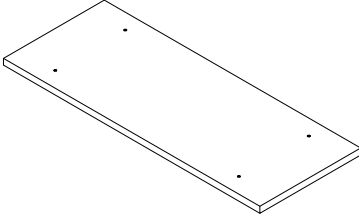
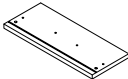



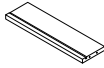
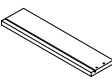
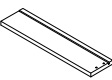
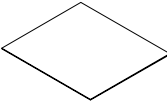
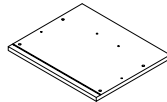
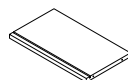
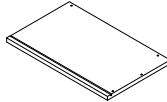
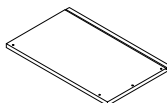
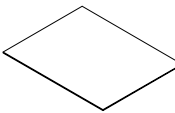
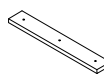



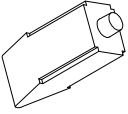

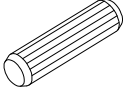

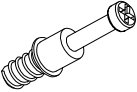

IDENTIFICATION DES PIÈCES
PARTS IDENTIFICATION

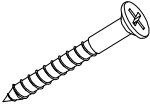
1		PANNEAU CÔTÉ GAUCHE LEFT SIDE PANEL	1MC 1PC
2		PANNEAU CÔTÉ DROIT RIGHT SIDE PANEL	1MC 1PC
3		PANNEAU CÔTÉ GAUCHE LEFT SIDE PANEL	1MC 1PC
4		PANNEAU CÔTÉ DROIT RIGHT SIDE PANEL	1MC 1PC
5		PANNEAU DU BAS BOTTOM PANEL	2MCX 2PCS
6		PANNEAU DU DESSUS TOP PANEL	2MCX 2PCS
7		PANNEAU ARRIÈRE BACK PANEL	2MCX 2PCS
8		PANNEAU ARRIÈRE BACK PANEL	1MC 1PC
9		PANNEAU DU DESSUS TOP PANEL	1MC 1PC
10		PANNEAU DEVANT GAUCHE DU TIROIR LEFT DRAWER FRONT PANEL	2MCX 2PCS

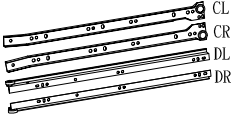
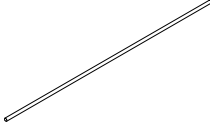
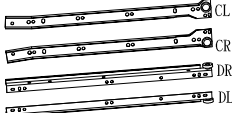
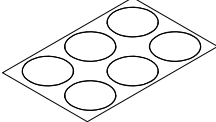
IDENTIFICATION DES PIÈCES
PARTS IDENTIFICATION

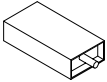
11		PANNEAU ARRIÈRE DU TIROIR DRAWER BACK PANEL	2MCX 2PCS
12		PANNEAU CÔTÉ GAUCHE DU TIROIR LEFT DRAWER SIDE PANEL	2MCX 2PCS
13		PANNEAU CÔTÉ DROIT DU TIROIR RIGHT DRAWER SIDE PANEL	2MCX 2PCS
14		PANNEAU DU FOND DU TIROIR DRAWER BOTTOM PANEL	2MCX 2PCS
15		PANNEAU DEVANT DROIT DU TIROIR RIGHT DRAWER FRONT PANEL	1MC 1PC
16		PANNEAU ARRIÈRE DU TIROIR DRAWER BACK PANEL	1MC 1PC
17		PANNEAU CÔTÉ GAUCHE DU TIROIR LEFT DRAWER SIDE PANEL	1MC 1PC
18		PANNEAU CÔTÉ DROIT DU TIROIR RIGHT DRAWER SIDE PANEL	1MC 1PC
19		PANNEAU DU FOND DU TIROIR DRAWER BOTTOM PANEL	1MC 1PC
20		PLAQUE TRANSVERSALE CROSS PANEL	2MCX 2PCS

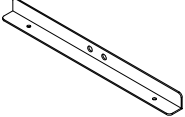
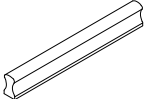
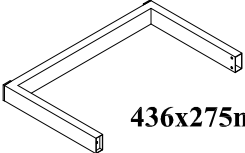
IDENTIFICATION DES PIÈCES DE MONTAGE
HARDWARE IDENTIFICATION

A		COLLE/GLUE(40g)	1MC / PC	L		35mm	6MCX / PCS
B		Ø8 x 30mm	32MCX / PCS	M		28mm	4MCX / PCS
C		35mm	18MCX / PCS	N		15mm	4MCX / PCS
D		Ø15x12mm	18MCX / PCS	O		28mm	6MCX / PCS
E		42mm	12MCX / PCS	P		57x21mm	1MC / PC
F		L 450mm	1 ENS / SET	Q		362mm	2MCX / PCS
G		L 400mm	2 ENS / SET	R		Ø20mm	3MCX / PCS
H		10mm	42MCX / PCS	S		80mm	4MCX / PCS
I		35mm	12MCX / PCS	T		300mm	2MCX / PCS
J		L 120mm	3MCX / PCS	U		436x275mm	2MCX / PCS
K		22.5mm	6MCX / PCS				

ÉTAPE / STEP 1

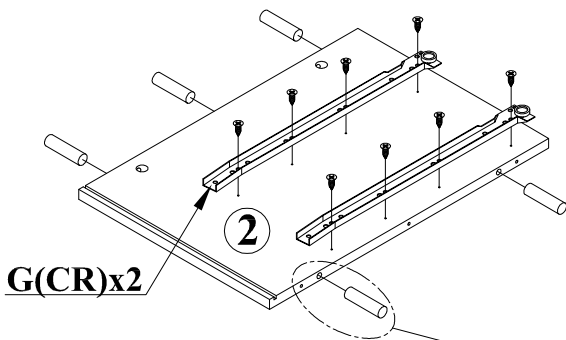
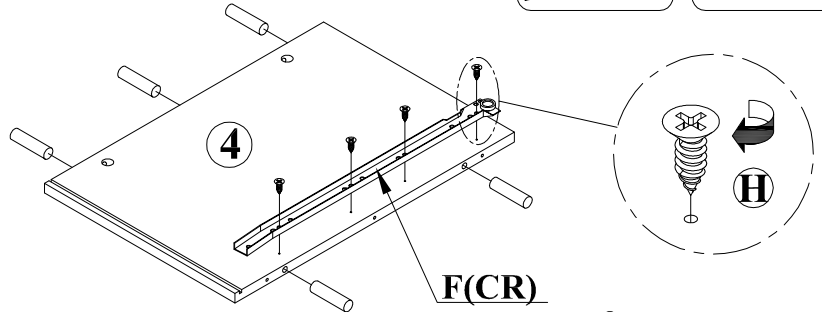
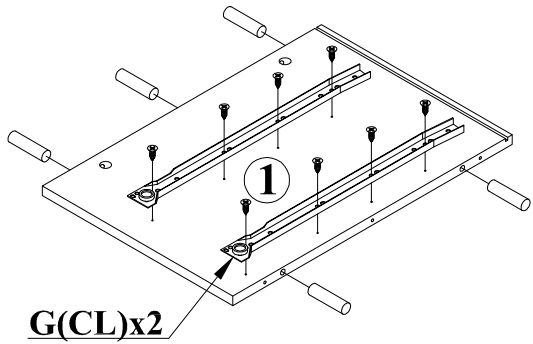
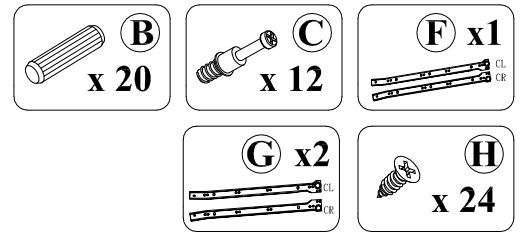

côté renversé /
 the reverse side

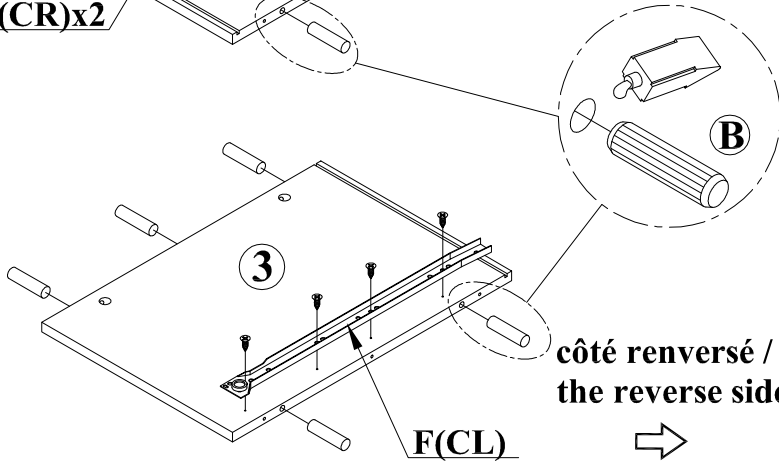
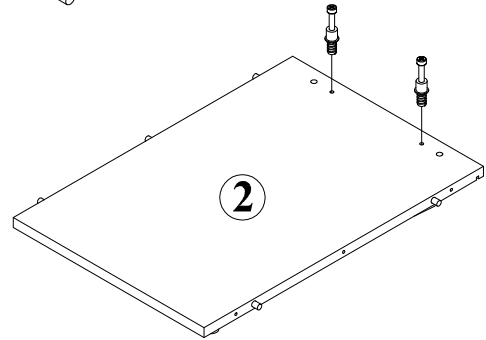

côté renversé /
 the reverse side

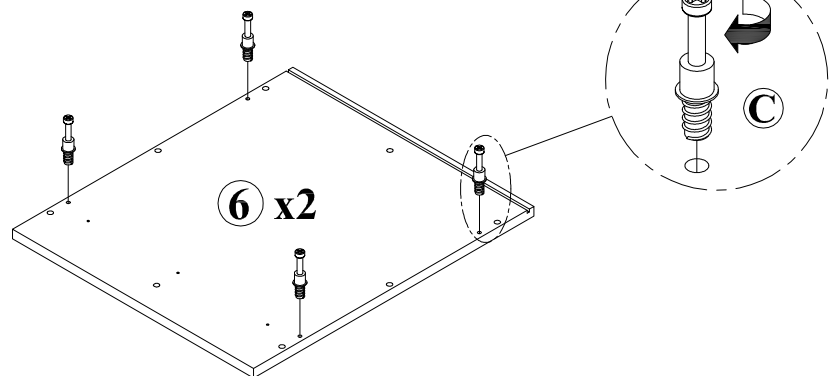
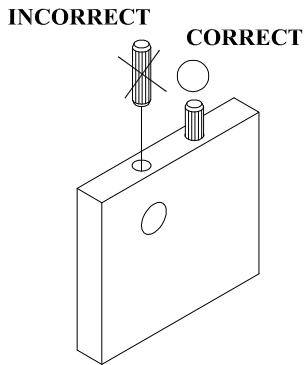
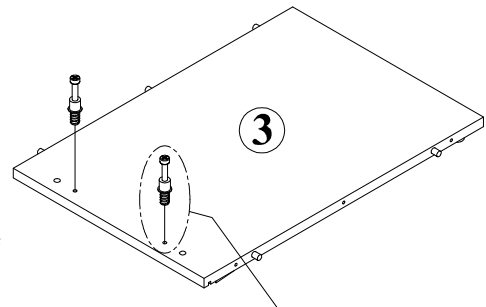

La colle (A) doit être utilisée aux endroits indiqués afin de solidifier l'étagère assemblée.
 The Glue (A) should be used in the indicated locations to help solidify the assembled unit.

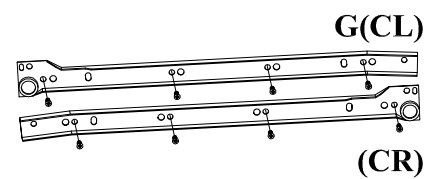
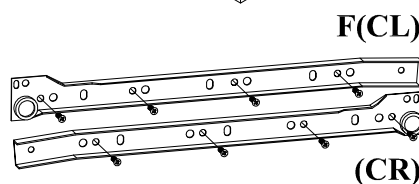

ÉTAPE / STEP 2

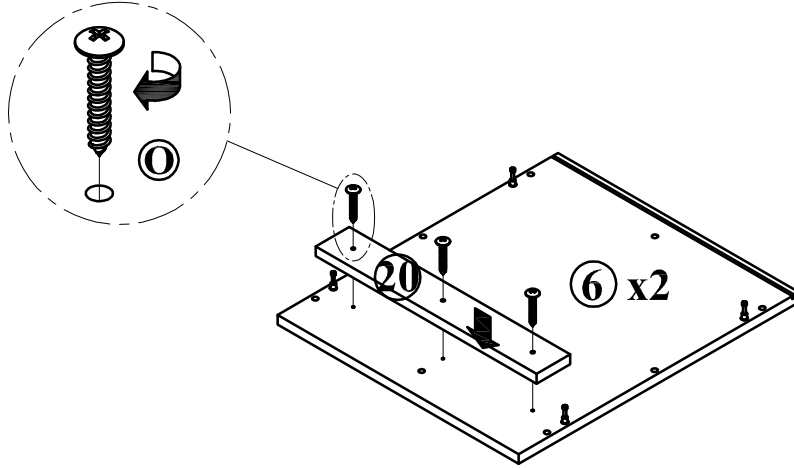
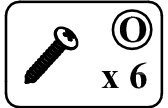

ÉTAPE / STEP 3

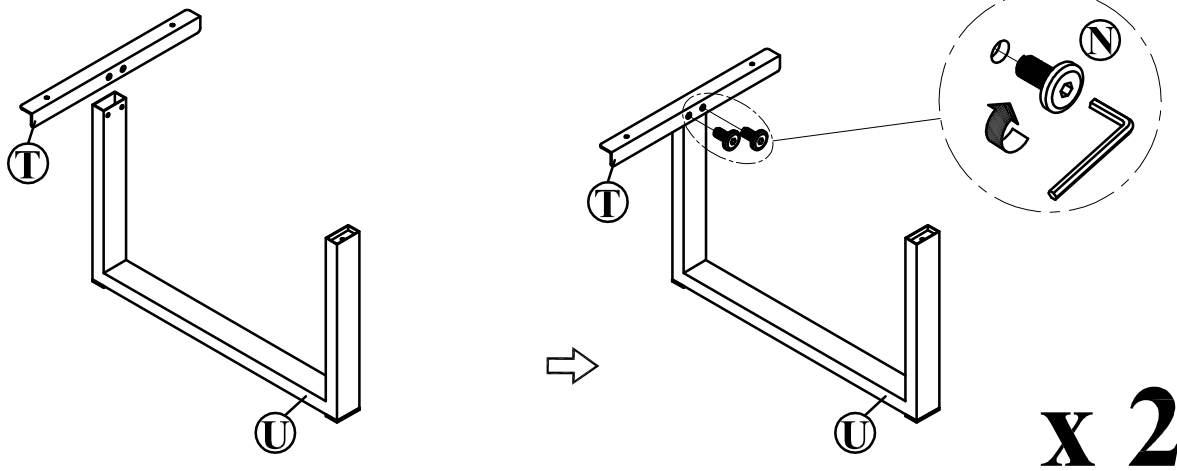
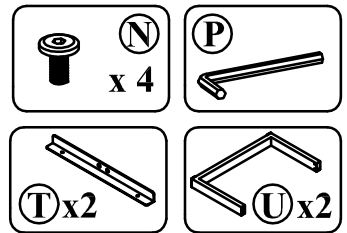

ÉTAPE / STEP 4

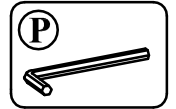
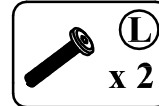
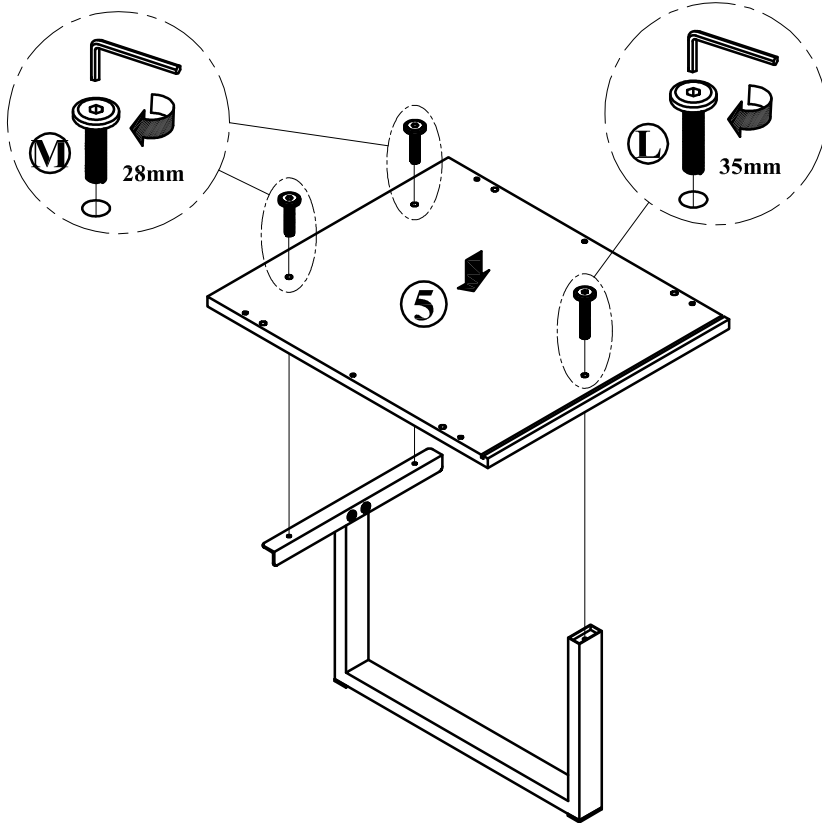

x 2

ÉTAPE / STEP 5

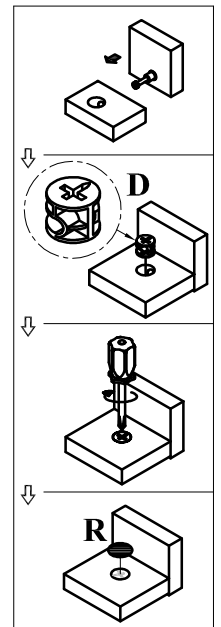
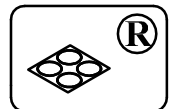
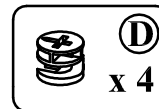
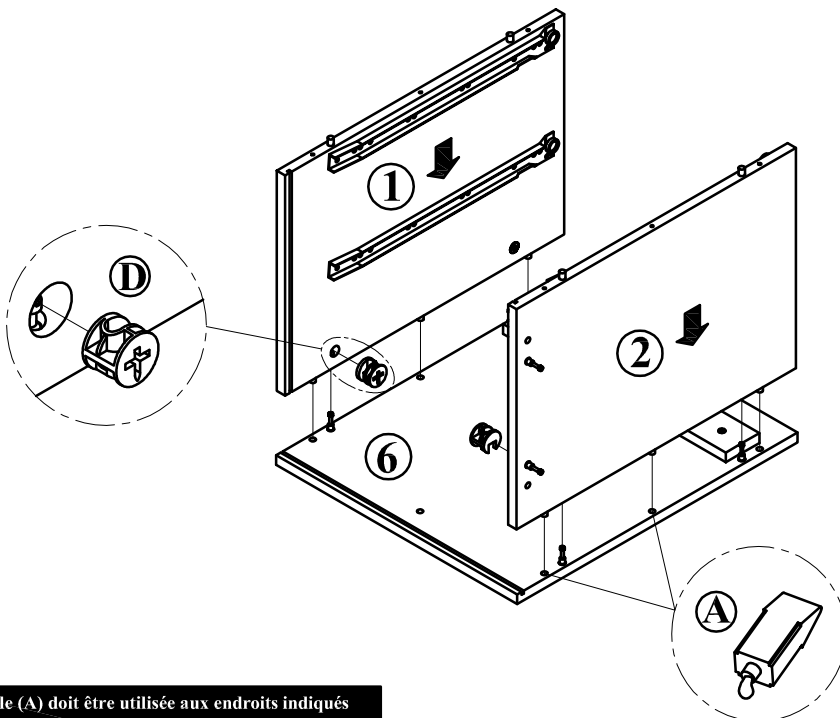

La colle (A) doit être utilisée aux endroits indiqués afin de solidifier l'étagère assemblée.
 The Glue (A) should be used in the indicated locations to help solidify the assembled unit.

ÉTAPE / STEP 6

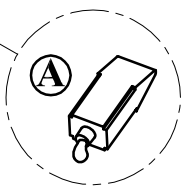
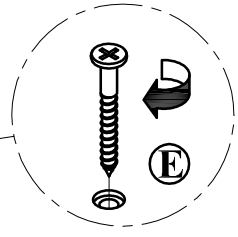
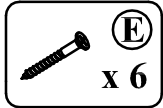
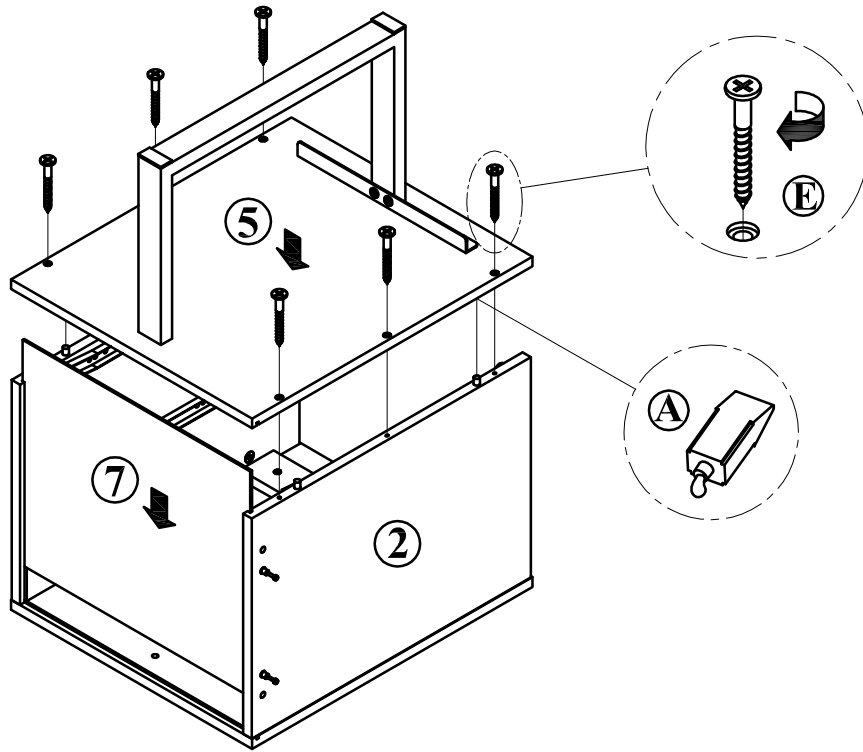

La colle (A) doit être utilisée aux endroits indiqués afin de solidifier l'étagère assemblée.
 The Glue (A) should be used in the indicated locations to help solidify the assembled unit.

ÉTAPE / STEP 7

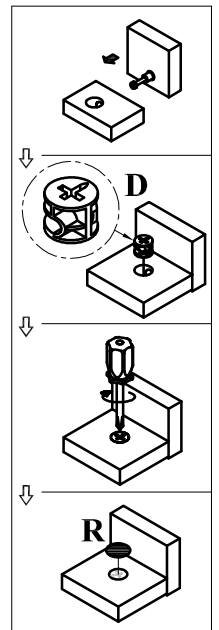
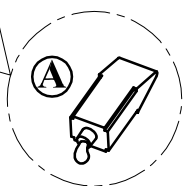
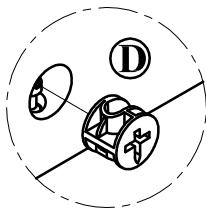
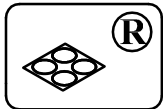
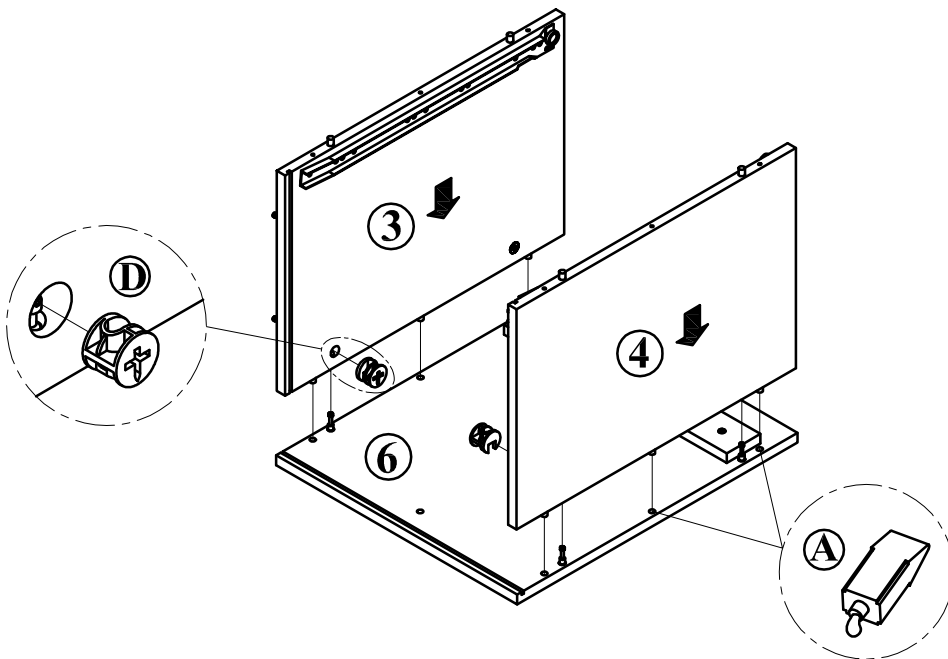

ÉTAPE / STEP 8

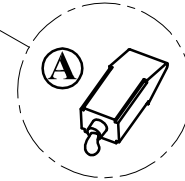
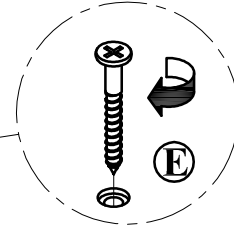
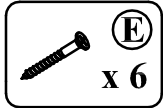
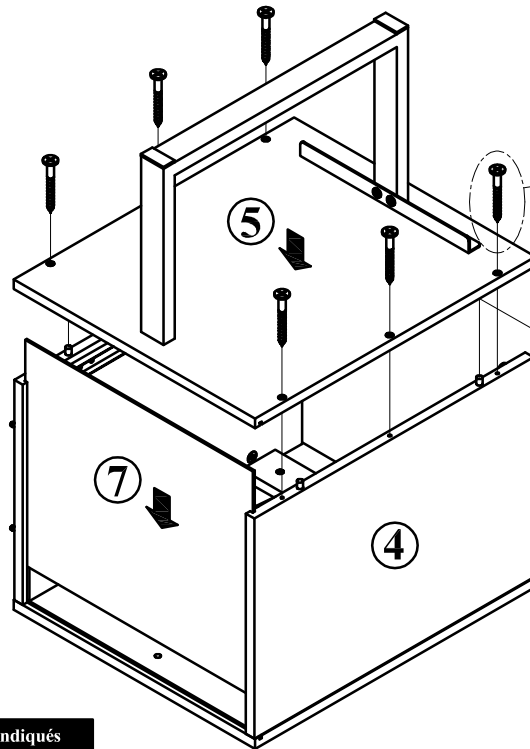

La colle (A) doit être utilisée aux endroits indiqués afin de solidifier l'étagère assemblée.
The Glue (A) should be used in the indicated locations to help solidify the assembled unit.

ÉTAPE / STEP 9

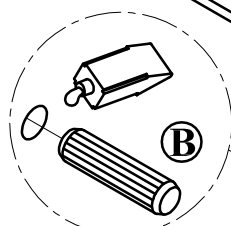
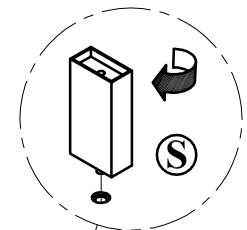
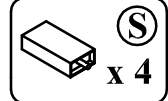
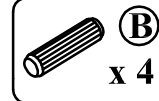
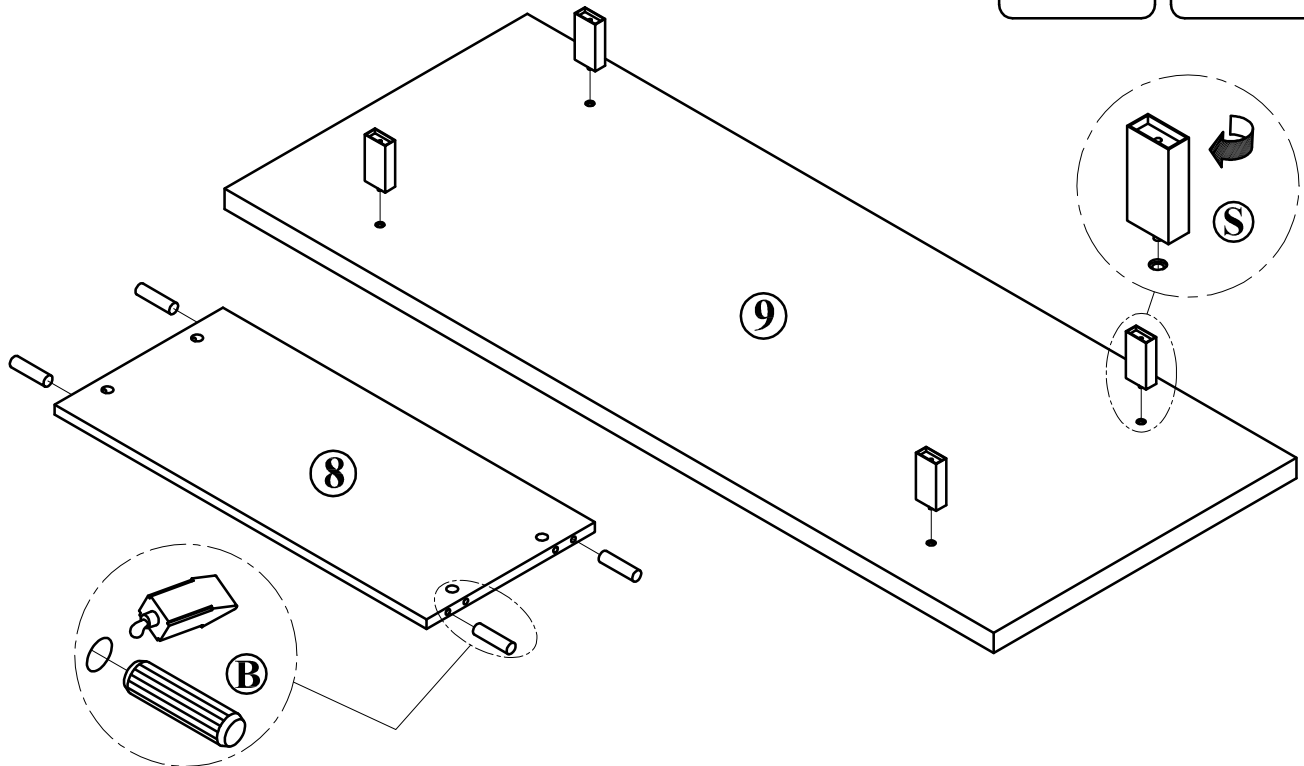

ÉTAPE / STEP 10

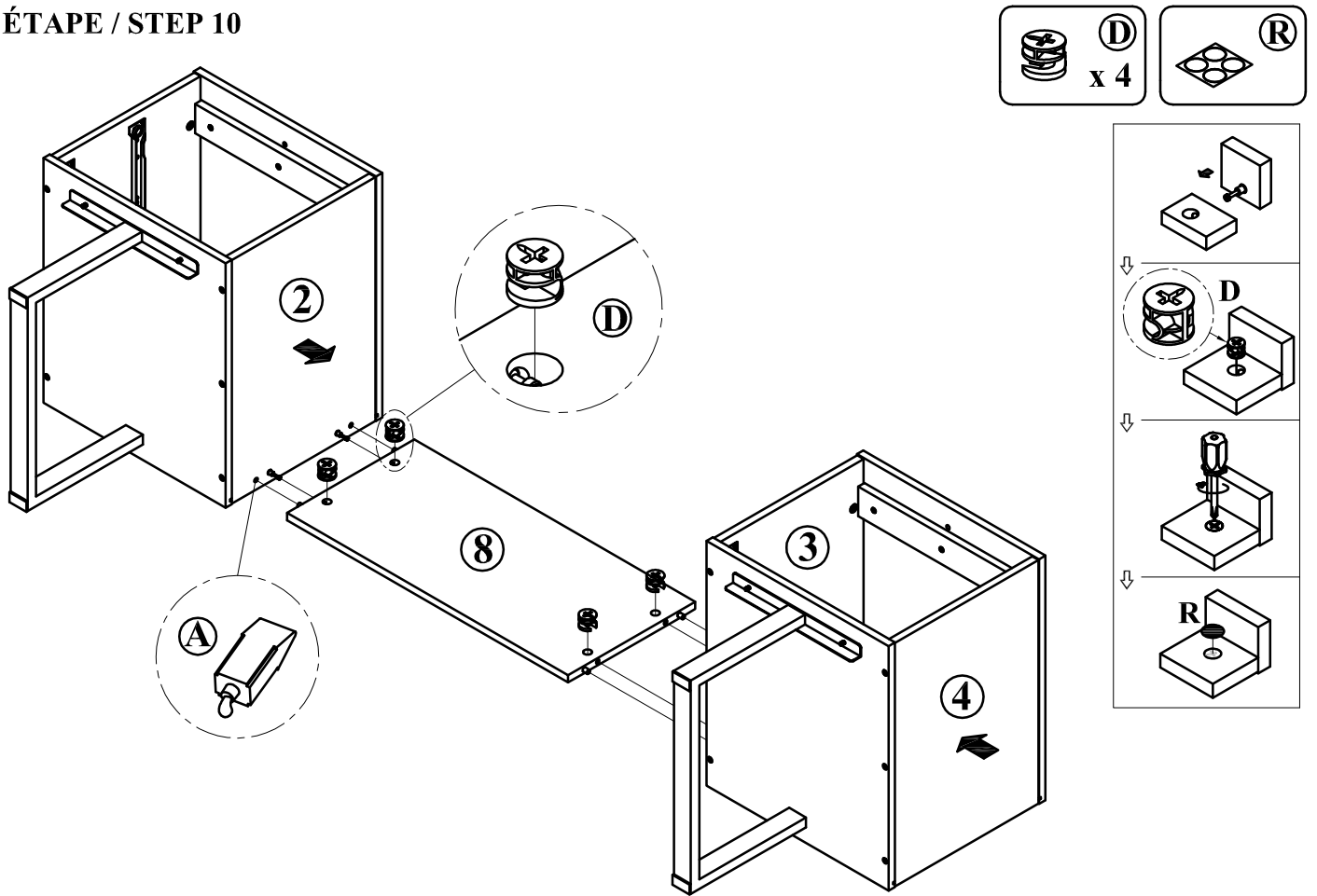

ÉTAPE / STEP 11

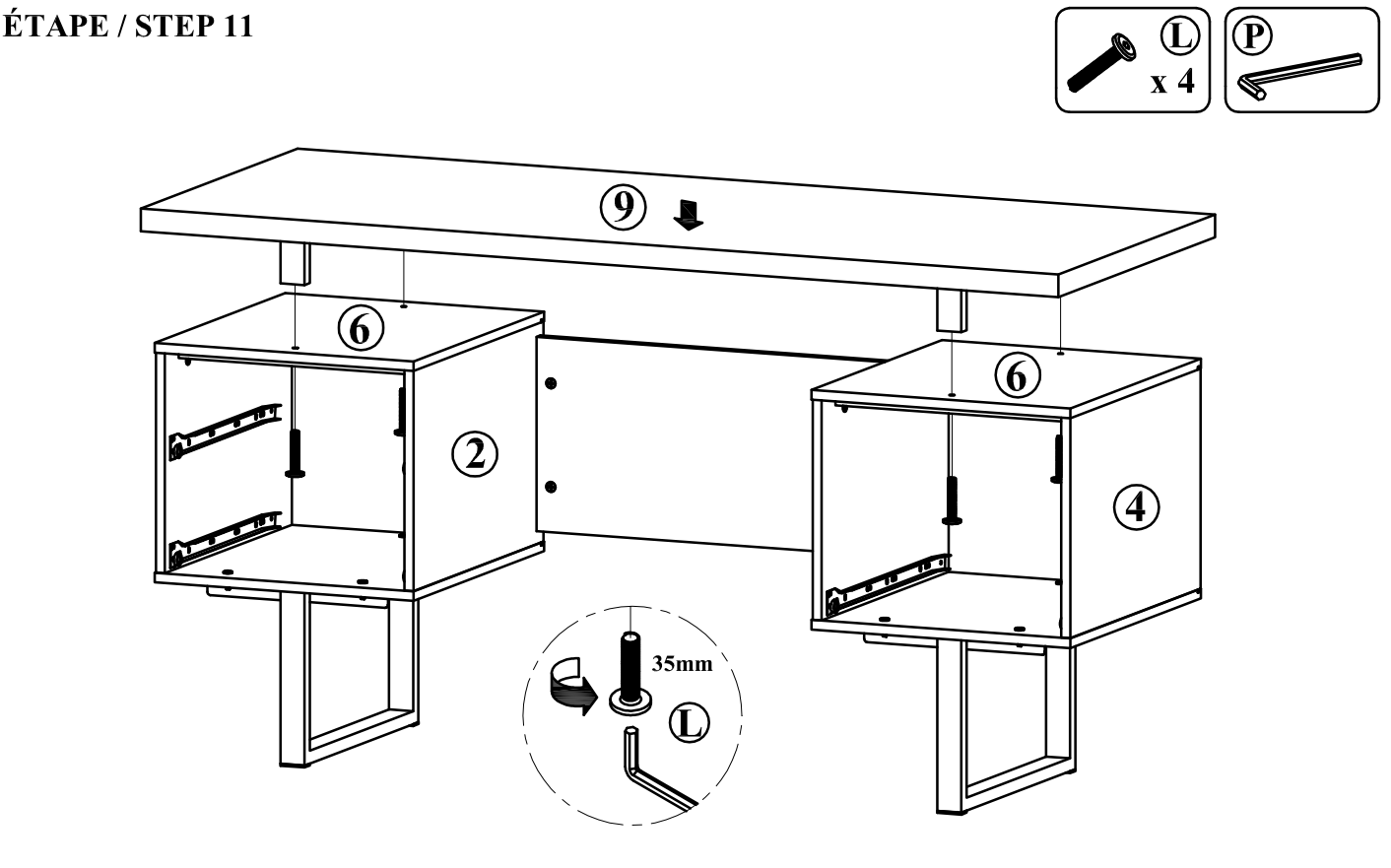

ÉTAPE / STEP 12

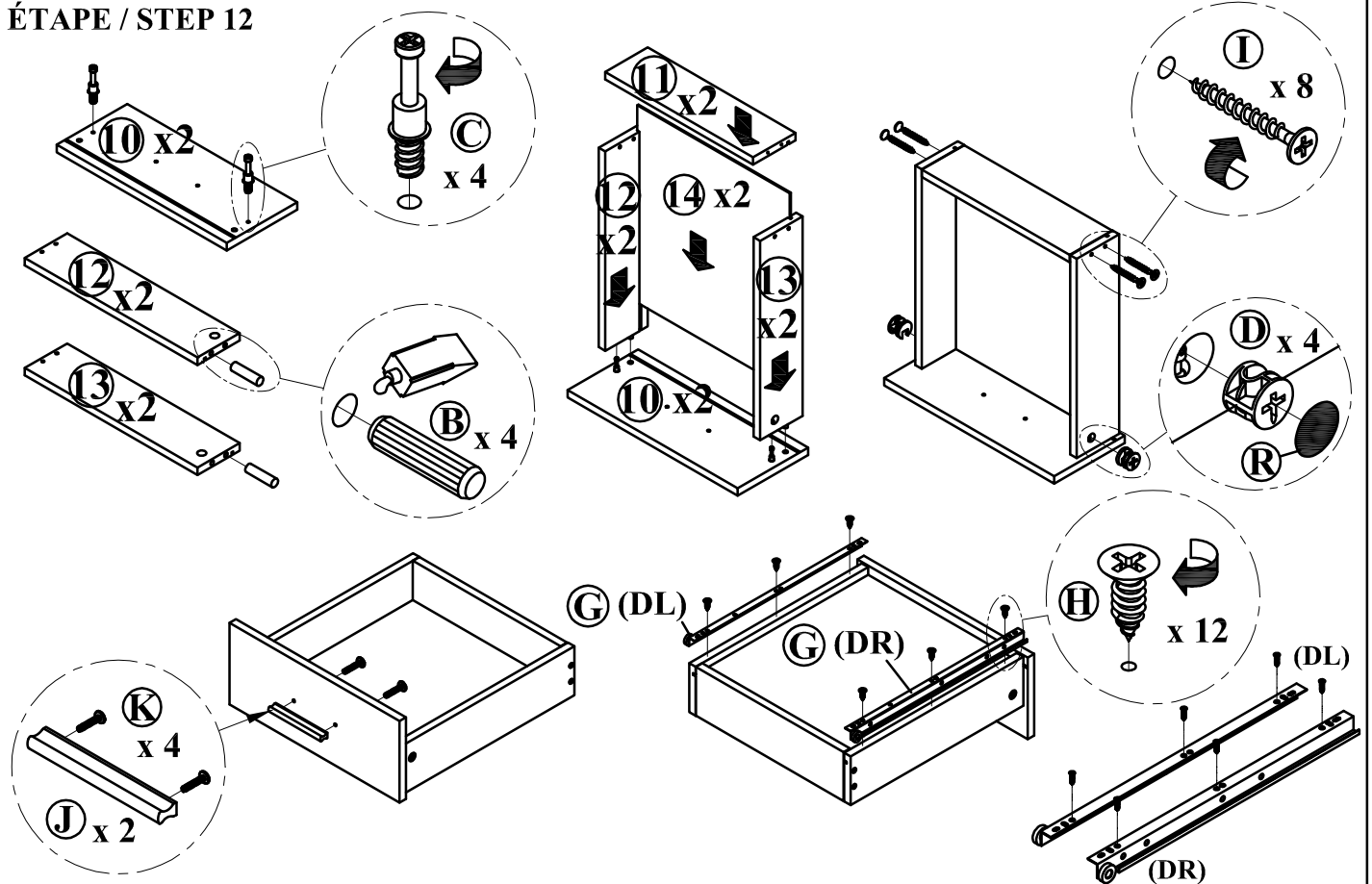

ÉTAPE / STEP 13

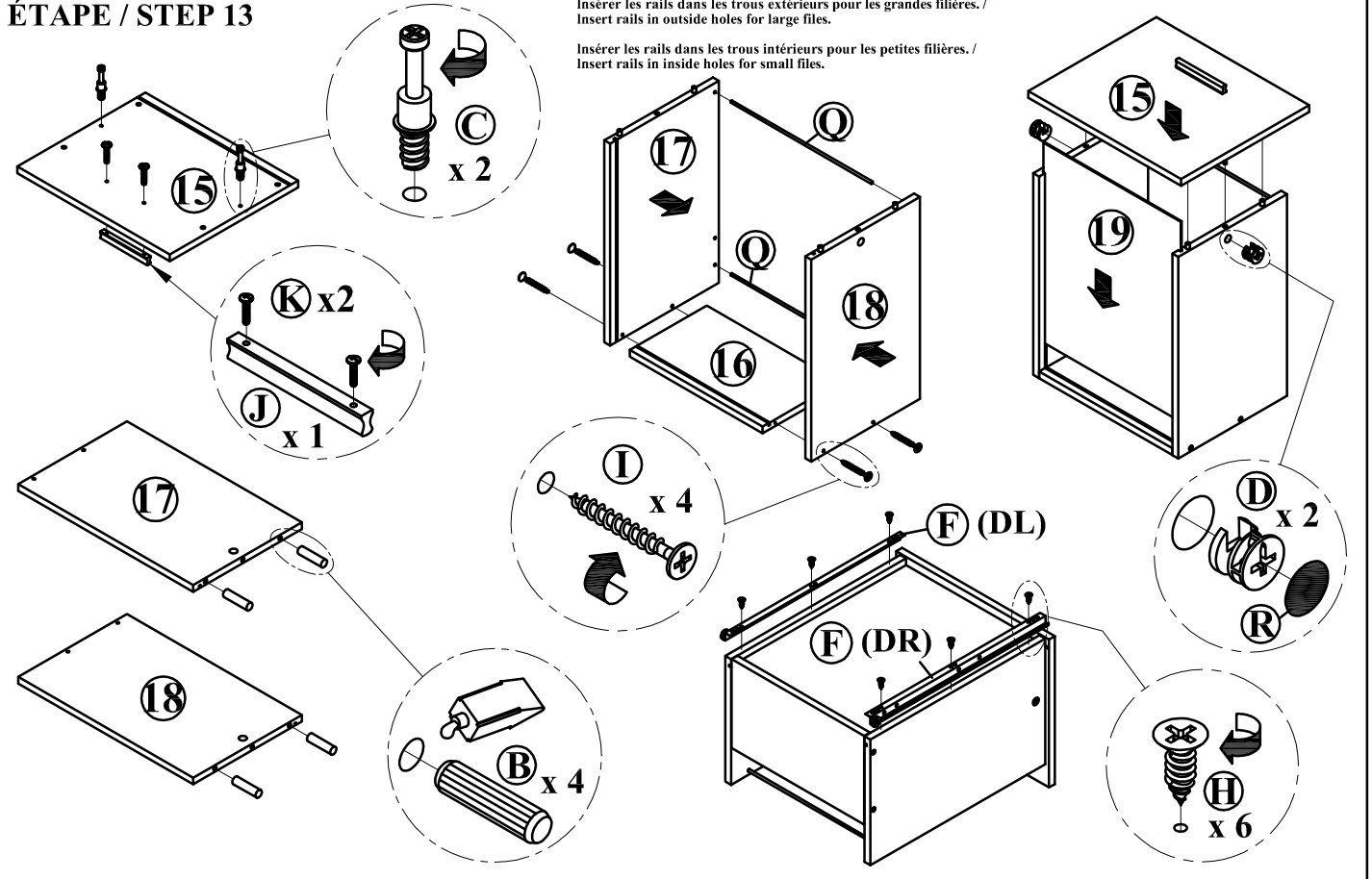

ÉTAPE / STEP 14

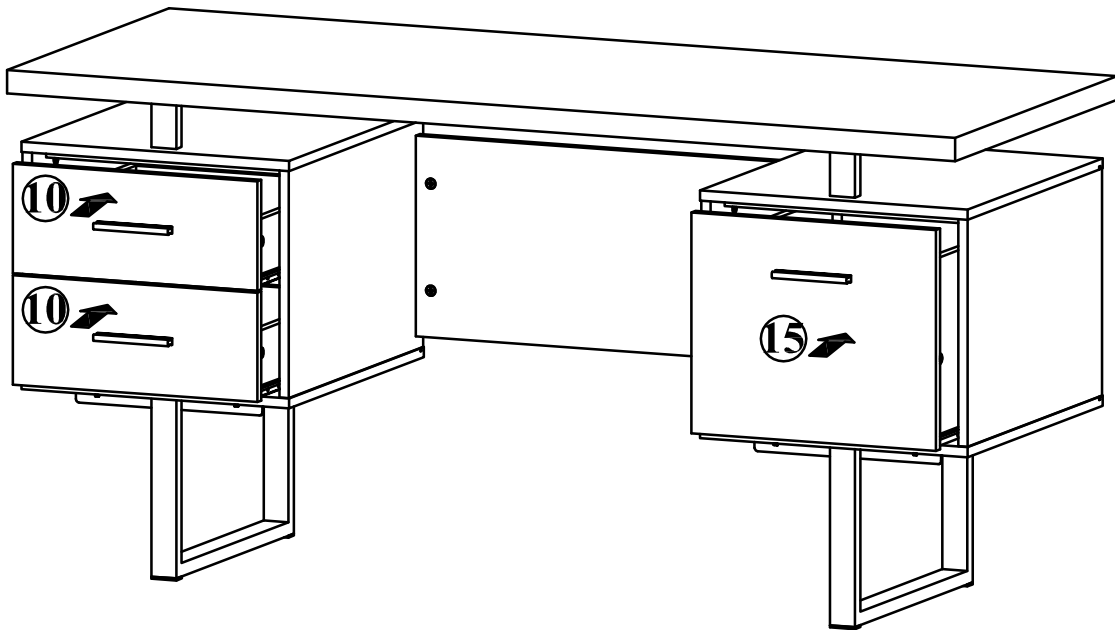

TERMINER / FINISH

