

30" JX3™ GAS DOWNDRAFT COOKTOP

JGD3430G – 29⁵⁹/₆₄" x 18⁵/₁₆" x 21¹/₂"

PRODUCT DIMENSIONS

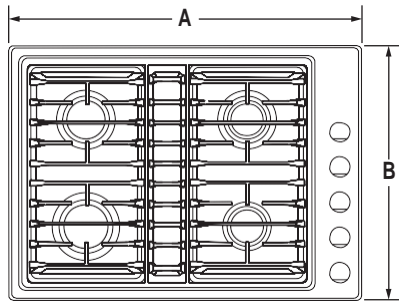

TOP VIEW

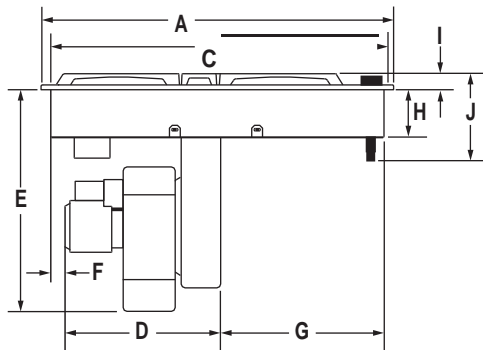

FRONT VIEW

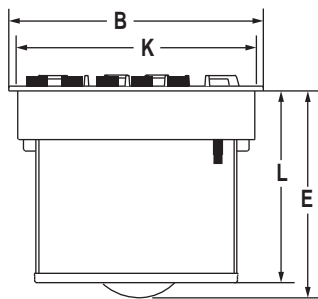

SIDE VIEW

MODEL#		JGD3430G	
		in	cm
A	Overall width	29 ⁵⁹ / ₆₄	76.0
B	Overall depth	21 ¹ / ₂	54.6
C	Width of cooktop base	28 ²⁵ / ₆₄	72.1
D	Width of assembled blower motor and plenum	14 ²⁹ / ₆₄	36.7
E	Height from blower motor to underside of cooktop	18 ⁵ / ₁₆	46.5
F	Width from left side of cooktop base to blower motor	1 ⁷ / ₃₂	3.1
G	Width from plenum to right side of cooktop base	12 ²³ / ₃₂	32.3
H	Height of cooktop base	4 ⁹ / ₆₄	10.5
I	Height of cooktop with grates	1 ³⁷ / ₆₄	4.0
J	Height from gas inlet to top of grates	6 ⁴⁷ / ₆₄	17.1
K	Depth of cooktop base	19 ⁶¹ / ₆₄	50.7
L	Height from plenum to underside of cooktop	16 ⁴⁹ / ₆₄	42.6

IMPORTANT: Dimensional specifications are provided for planning purposes only.

Do not make any cutouts based on this information. Refer to the Installation Guide *BEFORE* selecting cabinetry, verifying electrical/gas connections, making cutouts or beginning installation.

All Jenn-Air® appliances are appropriately UL, CUL or CSA approved.

30" JX3™ GAS DOWNDRAFT COOKTOP
JGD3430G – 29⁵⁹/₆₄" x 18⁵/₁₆" x 21¹/₂"

OPENING/CLEARANCE DIMENSIONS

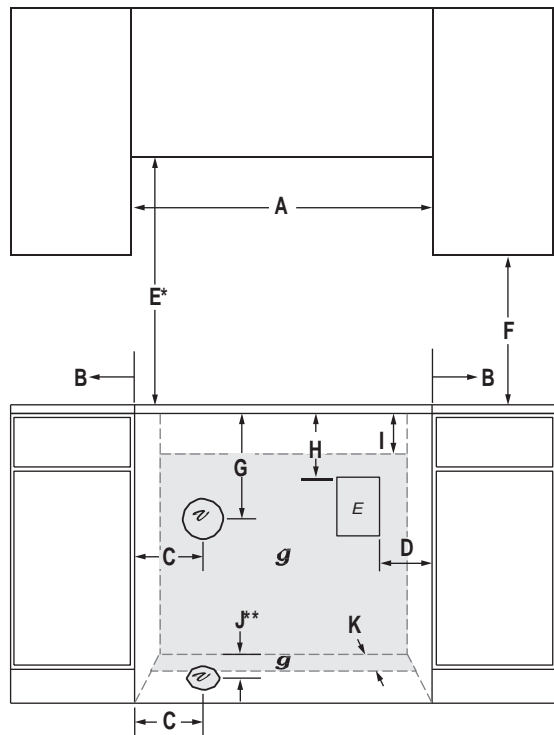

FRONT VIEW

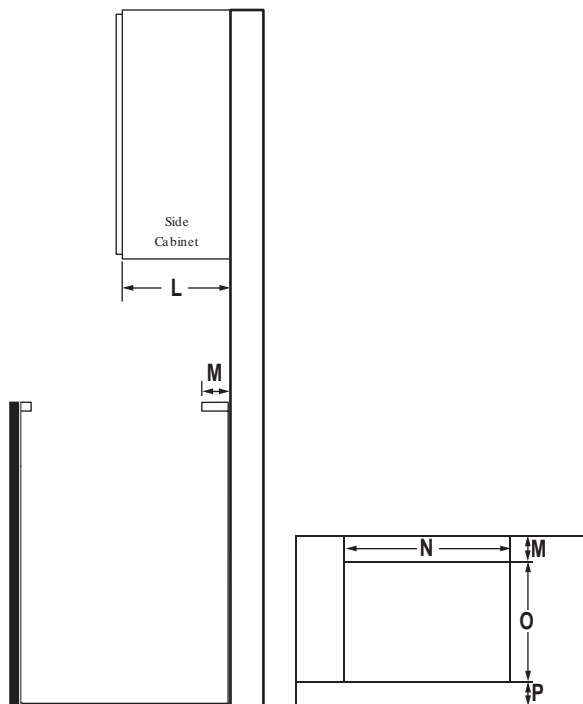

SIDE VIEW

TOP VIEW

MODEL#		JGD3430G	
		in	cm
A	Width of combustible area above cooking surface (min.)	30	76.2
B	Width from cooktop to fixed wall or other combustible material (min.)	6	15.2
C	Width to center of vent opening option (min.)	7 ¹ / ₈	20.0
D	Width to outer edge of outlet (min.)	10	25.4
E*	Height to bottom of uncovered wood or metal cabinet above cooking surface (min.)	30	76.2
F	Height to bottom of uncovered wood or metal cabinet (min.)	18	45.7
G	Height to center of vent opening option	14 ¹¹ / ₁₆	37.3
H	Height to top edge of outlet (min.)	12	30.5
I	Height to top of gas installation area (wall installation)	6	15.2
J**	Depth to center of vent opening option	17 ¹ / ₈	43.5
K	Depth of gas installation area (floor installation)	6	15.2
L	Depth of upper cabinet (recommended)	13	33.0
M	Depth from cutout to wall (min.)	2 ¹³ / ₃₂	6.1
N	Width of cutout	28 ⁵ / ₈	72.7
O	Depth of cutout	19 ¹⁵ / ₁₆	50.6
P	Depth from cutout to front of countertop (min.)	2 ¹ / ₈	5.4
E	Recommended electrical access location		
G	Recommended gas supply line location		
V	Recommended venting location – see pages 3-4 for ducting information		

*Dimension can be reduced by 6" (15.2 cm) when bottom of wood or metal cabinet is covered by not less than 1/4" (0.6 cm) flame retardant millboard covered with not less than No. 28 MSG sheet metal, 0.015" (0.4 mm) stainless steel, 0.024" (0.6 mm) aluminum or 0.020" (0.5 mm) copper.
 **Based on installation in a 24" (61.0 cm) deep by 34¹/₂" (87.6 cm) high base cabinet with a 1¹/₂" (3.8 cm) thick counter top.

GAS REQUIREMENTS

Natural Gas

This cooktop is factory-set for use with natural gas.

LP Gas Conversion

Conversion must be done by a qualified service technician. To convert to LP gas, use the LP gas conversion kit provided with the cooktop.

ELECTRICAL REQUIREMENTS

120 volt, 60 Hz, AC only, 40-amp fused, electrical circuit is required. A time-delay fuse or dedicated circuit is recommended.

VENTING REQUIREMENTS

This cooktop must be exhausted outdoors unless using the duct-free filter kit (JDA7000WX). Refer to kit instructions for further information.

LOCATION REQUIREMENTS

- To ensure cooktop base clearance, cabinet side walls need to be wider than the cutout.
- A minimum clearance of 2" (5.1 cm) is recommended between the blower motor and cabinet for proper cooling. A 6" (15.2 cm) clearance is recommended for servicing access.
- An under counter built-in oven cannot be installed under this cooktop.

IMPORTANT: Dimensional specifications are provided for planning purposes only.

Do not make any cutouts based on this information. Refer to the Installation Guide *BEFORE* selecting cabinetry, verifying electrical/gas connections, making cutouts or beginning installation.

All Jenn-Air® appliances are appropriately UL, CUL or CSA approved.



DUCT-FREE KIT

JDA7000WX – 17⁵/₈" x 10³/₈" x 7¹/₂"

JX3™ DOWNDRAFT COOKTOPS WITH DUCT-FREE VENTILATION

The duct-free filter kit (JDA7000WX) is approved for use with JX3™ downdraft cooktop models JGD3536G, JGD3430G, JED4536G, JED3536G, JED4430G and JED3430G. The kit filters the air from the downdraft system and ventilates the conditioned air into the room through the toe kick of the base cabinet. Do not ventilate the air from the downdraft system into the base cabinet, base cabinet pedestal, crawl space, wall or attic.

PRODUCT DIMENSIONS

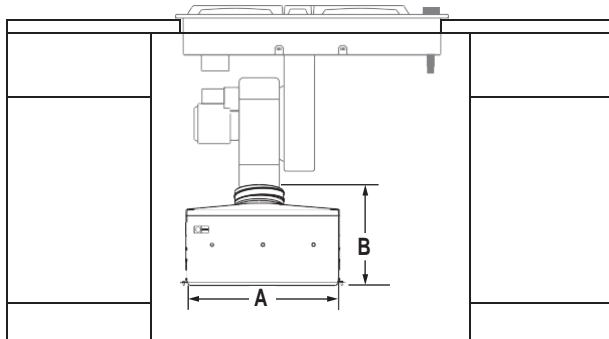

FRONT VIEW

MODEL#		JDA7000WX	
		in	cm
A	Width of housing	17 ⁵ / ₈	44.7
B	Height of housing	10 ³ / ₈	26.5
C	Depth of housing	7 ¹ / ₂	19.0
D	Minimum height of toe kick	3	7.6
E	Minimum depth to toe kick	2 ¹ / ₂	6.4

EXHAUST CUTOUT LOCATION

The cutout location in the toe kick area of the cabinet floor is dependent upon the dimensions of the cooktop and base cabinet.

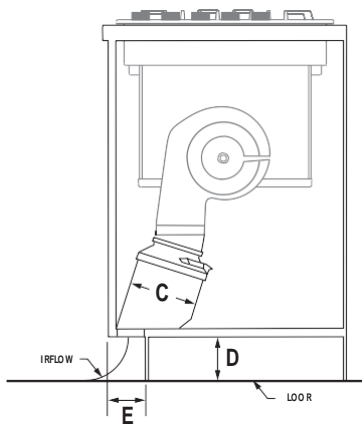

SIDE VIEW

IMPORTANT: Dimensional specifications are provided for planning purposes only. Do not make any cutouts based on this information. Refer to the Installation Guide BEFORE selecting cabinetry, verifying electrical/gas connections, making cutouts or beginning installation. All Jenn-Air® appliances are appropriately UL, CUL or CSA approved.

DOWNDRAFT COOKTOP DUCTING ARRANGEMENTS

The diagrams below show typical duct arrangements for downdraft cooktops. JX3™ downdraft cooktops also offer a duct-free installation option. For more details, refer to page 3.

DUCTING CONFIGURATIONS

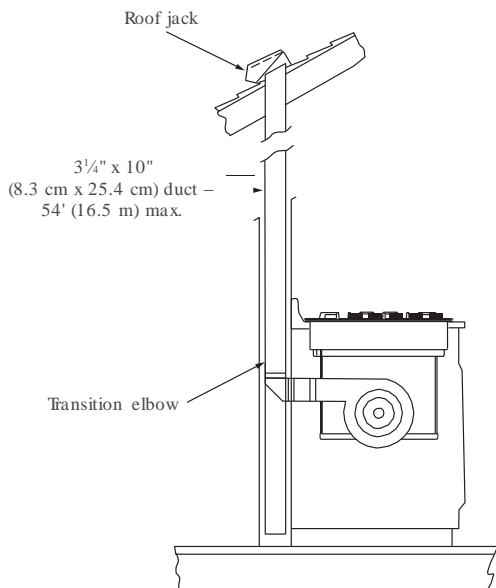

DUCTING REQUIREMENTS

COOKTOP	DUCT LENGTH	DUCT SIZE
Gas	10' (3.0 m) or less*	5" (12.7 cm) diameter*
	Between 10' (3.0 m) and 60' (18.3 m)	6" (15.2 cm) diameter 3 1/4" x 10" (8.3 cm x 25.4 cm)
Electric	10' (3.0 m) or less**	5" (12.7 cm) diameter**
	Between 10' (3.0 m) and 60' (18.3 m)	6" (15.2 cm) diameter 3 1/4" x 10" (8.3 cm x 25.4 cm)

* Gas cooktops must use 5" (12.7 cm) diameter for runs of 10' (3.0 m) or less.
 ** May be used to vent straight out the back of the cooktop and directly through the wall.

REAR DUCTING IN WALL TO ROOF

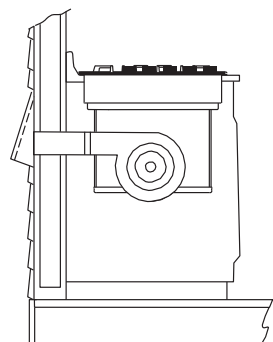

CALCULATING MAXIMUM DUCTING LENGTH

- Maximum ducting length is 60' (18.3 m).
- Each 90° elbow equals 5' (1.5 m) duct.
- Use no more than three 90° elbows.
- Flexible metal vent is not recommended.
- Do not install two elbows together.

NOTES:

- For ducting runs up to 30' (9.1 m), install cooktop as shipped.
- For ducting runs of 31' (9.4 m) to 60' (15.2 cm), remove the restricter ring on the blower inlet housing.
- For altitudes above 4500' (1272.0 m), reduce recommended vent run by 20% for best performance.

REAR DUCTING THROUGH WALL TO OUTSIDE

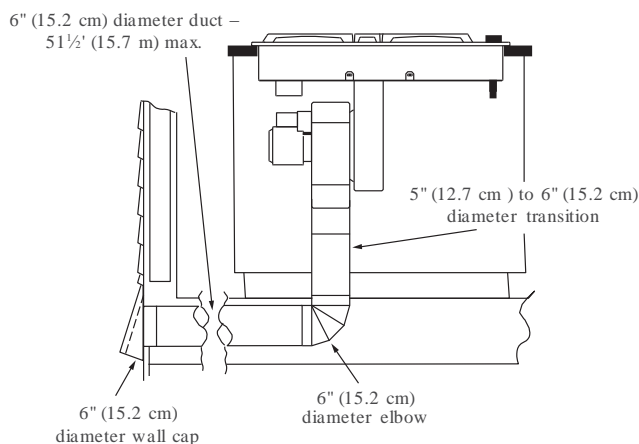
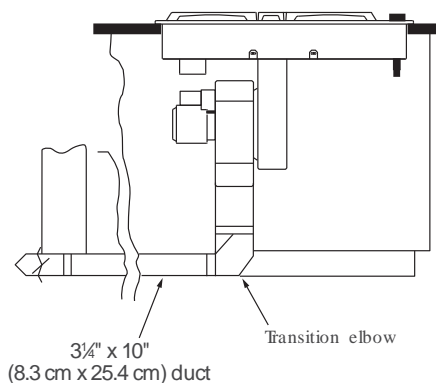

SIDE DUCTING IN TOE KICK TO OUTSIDE

THROUGH FLOOR BETWEEN JOISTS TO OUTSIDE

IMPORTANT: Dimensional specifications are provided for planning purposes only. Do not make any cutouts based on this information. Refer to the Installation Guide BEFORE selecting cabinetry, verifying electrical/gas connections, making cutouts or beginning installation. All Jenn-Air® appliances are appropriately UL, CUL or CSA approved.