



**INSTRUCTIONS D'ASSEMBLAGE**  
**ASSEMBLY INSTRUCTIONS**

---

**M**ONARCH  
SPECIALTIES INC.

**I 7149**

---

**BUREAU -**  
**48" L / BLANC / METAL ARGENT**

**COMPUTER DESK -**  
**48" L / WHITE / SILVER METAL**



**POUR DE L'ASSISTANCE OU POUR COMMANDER  
DES PIÈCES CONTACTEZ NOTRE DÉPARTEMENT  
DE SERVICE À LA CLIENTÈLE.**

**FOR ASSISTANCE OR TO ORDER PARTS  
CONTACT OUR CUSTOMER SERVICE DEPARTMENT**

**WWW.MONARCHSERVICE.COM**

**LISTE DES PIÈCES**  
**PARTS LIST**

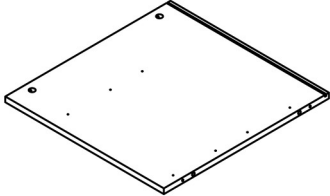
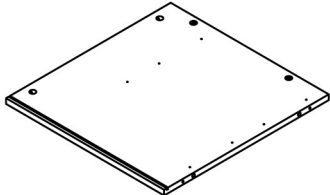
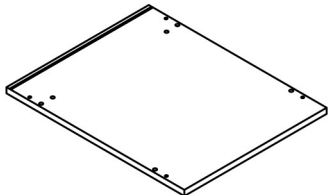
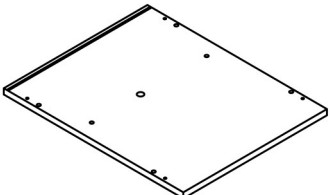
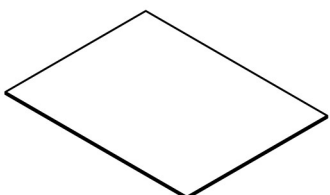
PIÈCE / PART #	IMAGE	DESCRIPTION	QTY / QTÉ
1		FRONT FACING LEFT SIDE PANEL PANNEAU DE CÔTÉ GAUCHE	1
2		FRONT FACING RIGHT SIDE PANEL PANNEAU DE CÔTÉ AVANT DROIT	1
3		BOTTOM PANEL PANNEAU DU BAS	1
4		TOP PANEL PANNEAU DE SURFACE	1
5		BACK PANEL PANNEAU ARRIÈRE	1

**LISTE DES PIÈCES**  
**PARTS LIST**

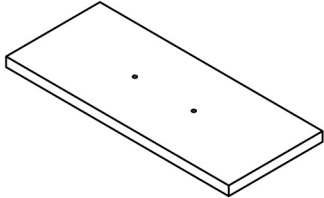
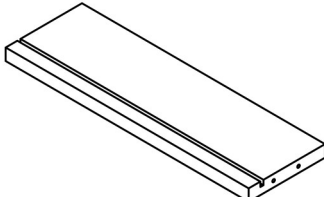
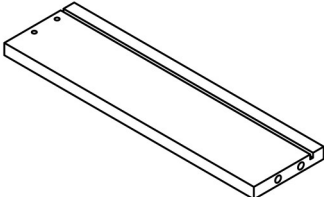
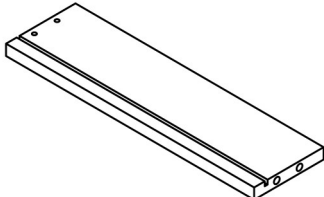
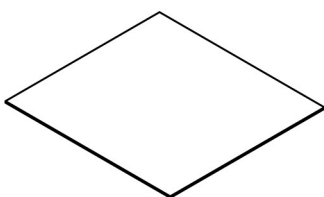
PIÈCE / PART #	IMAGE	DESCRIPTION	QTY / QTÉ
6		DRAWER FRONT PANEL PANNEAU AVANT TIROIR	1
7		DRAWER BACK PANEL PANNEAU ARRIÈRE TIROIR	1
8		DRAWER SIDE PANEL PANNEAU DE CÔTÉ TIROIR	1
9		DRAWER SIDE PANEL PANNEAU DE CÔTÉ TIROIR	1
10		DRAWER BOTTOM PANEL PANNEAU DU BAS TIROIR	1

**LISTE DES PIÈCES**  
**PARTS LIST**

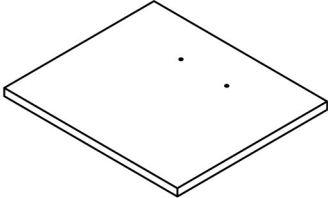
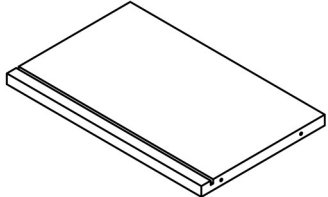
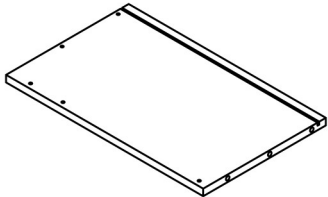
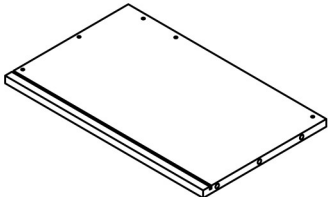
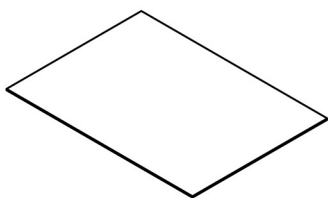
PIÈCE / PART #	IMAGE	DESCRIPTION	QTY / QTÉ
11		DRAWER FRONT PANEL PANNEAU AVANT TIROIR	1
12		DRAWER BACK PANEL PANNEAU ARRIÈRE TIROIR	1
13		DRAWER SIDE PANEL PANNEAU DE CÔTÉ TIROIR	1
14		DRAWER SIDE PANEL PANNEAU DE CÔTÉ TIROIR	1
15		DRAWER BOTTOM PANEL PANNEAU DU BAS TIROIR	1

**LISTE DES PIÈCES**  
**PARTS LIST**

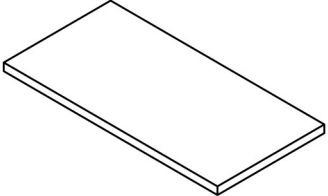
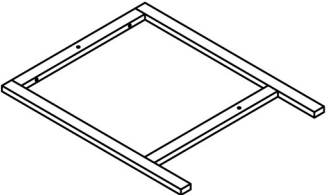
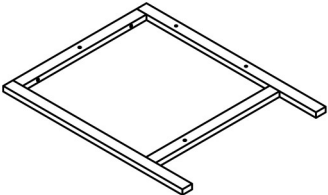
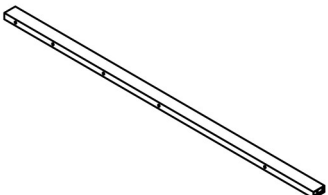
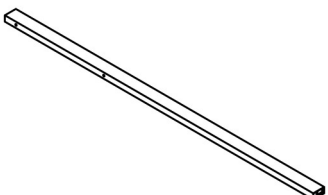
PIÈCE / PART #	IMAGE	DESCRIPTION	QTY / QTÉ
16		TABLE TOP SURFACE DE TABLE	1
17		FRONT FACING LEFT LEG PATTE AVANT GAUCHE	1
18		FRONT FACING RIGHT LEG PATTE AVANT DROITE	1
19		SUPPORT BAR BARRE DE SOUTIEN	1
20		SUPPORT BAR BARRE DE SOUTIEN	1

**LISTE DES PIÈCES DE MONTAGE**  
**HARDWARE LIST**

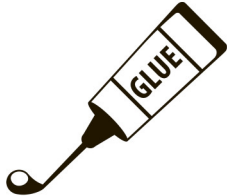
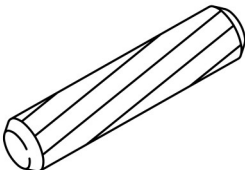
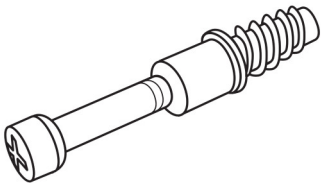
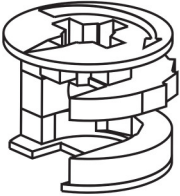
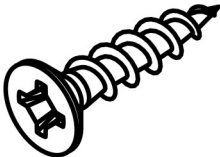
PIÈCE / PART #	IMAGE	DESCRIPTION	QTY / QTÉ
A		GLUE - 15G COLLE - 15G	1
B		WOOD DOWEL - Ø3/8" X 1 1/8" GOUJON DE BOIS - Ø3/8" X 1 1/8"	14
C		CAM LOCK SCREW - 1 3/8" VIS CAM LOCK - 1 3/8"	8
D		CAM LOCK CONNECTOR - Ø5/8" X 1/2" ÉCROU CAM LOCK - Ø5/8" X 1/2"	8
E		ASSEMBLING SCREW - 1 3/8" VIS D'ASSEMBLAGE - 1 3/8"	8

**LISTE DES PIÈCES DE MONTAGE**  
**HARDWARE LIST**

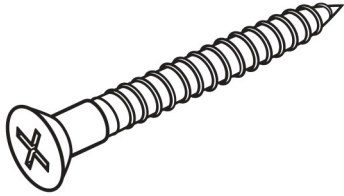
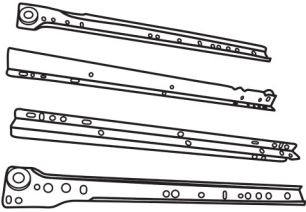
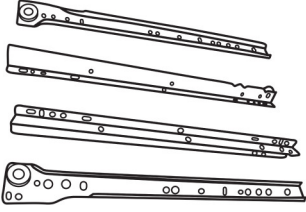
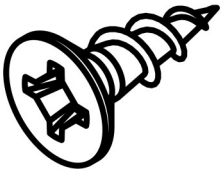
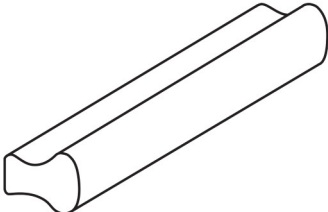
PIÈCE / PART #	IMAGE	DESCRIPTION	QTY / QTÉ
<b>F</b>		ASSEMBLING SCREW - 1 5/8" VIS D'ASSEMBLAGE - 1 5/8"	<b>4</b>
<b>G</b>		METAL DRAWER SLIDE - 13 3/4" COULISSE DE MÉTAL - 13 3/4"	<b>1</b>
<b>H</b>		METAL DRAWER SLIDE - 17 3/4" COULISSE DE MÉTAL - 17 3/4"	<b>1</b>
<b>I</b>		ASSEMBLING SCREW - 1/2" VIS D'ASSEMBLAGE - 1/2"	<b>26</b>
<b>J</b>		HANDLE - 4 3/4" POIGNÉE - 4 3/4"	<b>2</b>

**LISTE DES PIÈCES DE MONTAGE**  
**HARDWARE LIST**

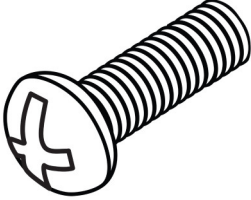
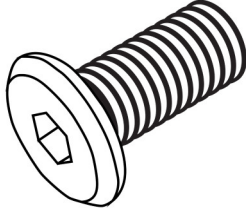
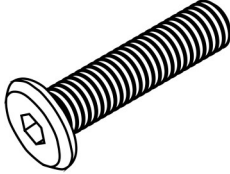
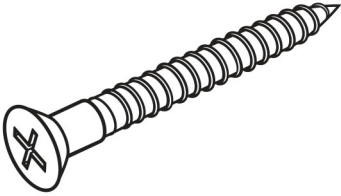
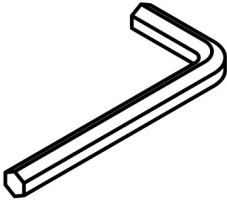
PIÈCE / PART #	IMAGE	DESCRIPTION	QTY / QTÉ
<b>K</b>		ASSEMBLING BOLT - 7/8" BOULON D'ASSEMBLAGE - 7/8"	4
<b>L</b>		ASSEMBLING BOLT - 1 1/8" BOULON D'ASSEMBLAGE - 1 1/8"	6
<b>M</b>		ASSEMBLING BOLT - 2 1/2" BOULON D'ASSEMBLAGE - 2 1/2"	8
<b>N</b>		ASSEMBLING SCREW - 2 1/2" VIS D'ASSEMBLAGE - 2 1/2"	3
<b>O</b>		HEX KEY CLÉ HEXAGONALE	1

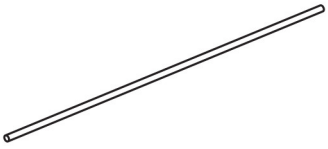
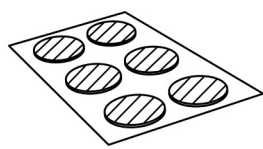

**LISTE DES PIÈCES DE MONTAGE**  
**HARDWARE LIST**

PIÈCE / PART #	IMAGE	DESCRIPTION	QTY / QTÉ
P		<p align="center">HANGING FOLDER BAR - 13" BARRE DE DOSSIER SUSPENDUE - 13"</p>	2
Q		<p align="center">FINISHING STICKER - Ø3/4" COLLANT DE FINITION - Ø3/4"</p>	8

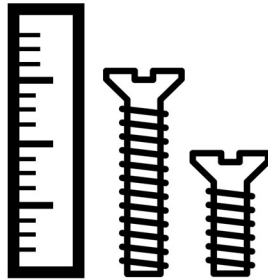

OUTIL DE VÉRIFICATION DE DIMENSIONS DES PIÈCES  
HARDWARE DIMENSIONS VERIFICATION TOOL

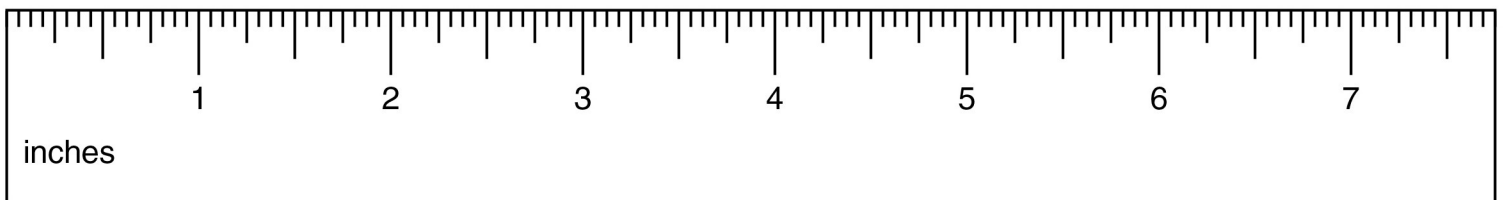

**ÉTAPE / STEP 1**

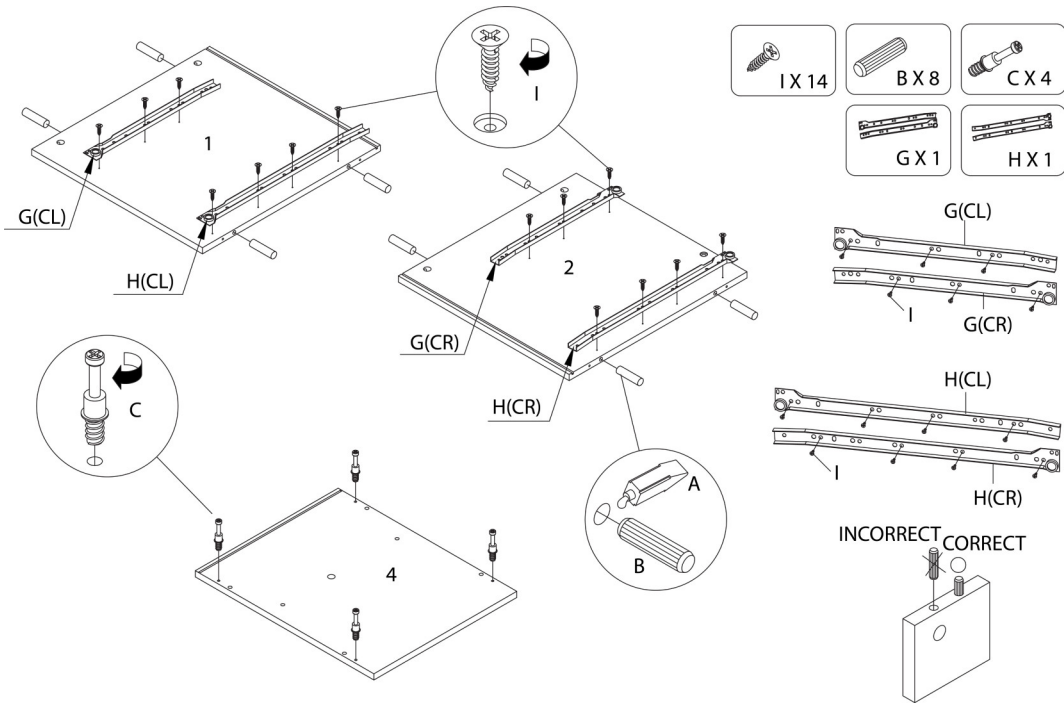

**ÉTAPE / STEP 2**

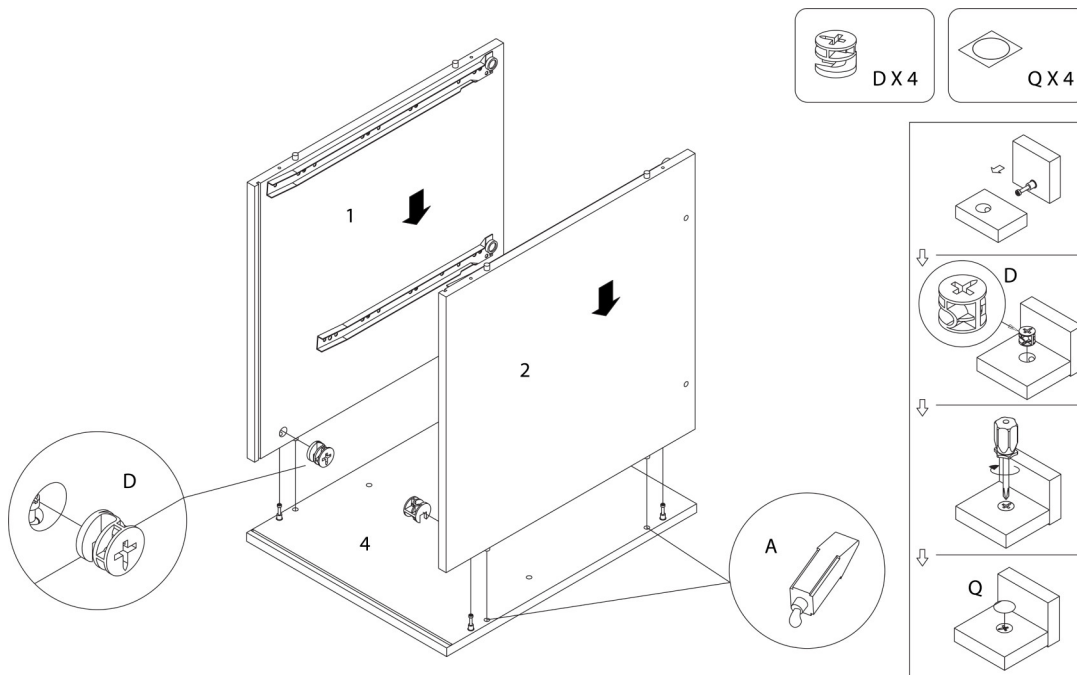

ÉTAPE / STEP 3

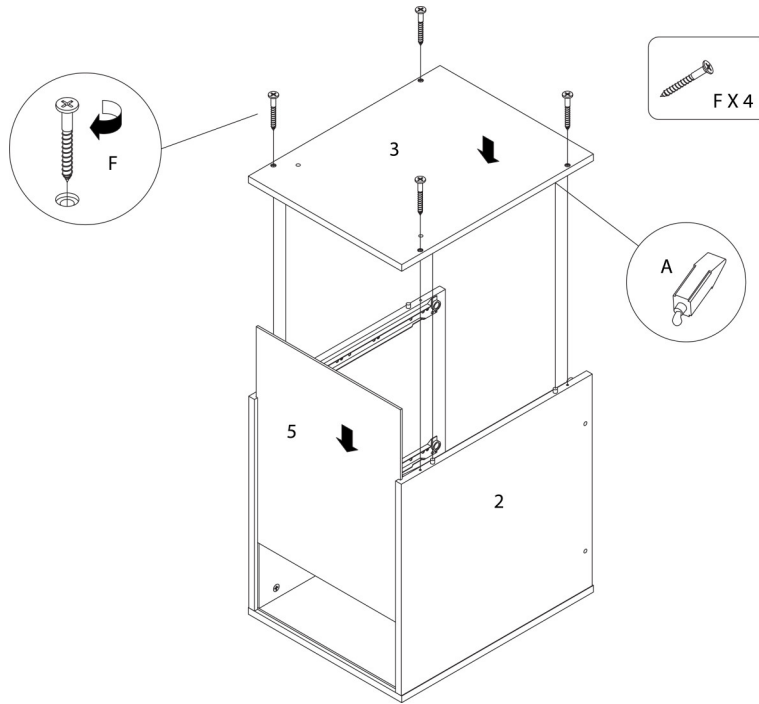

ÉTAPE / STEP 4

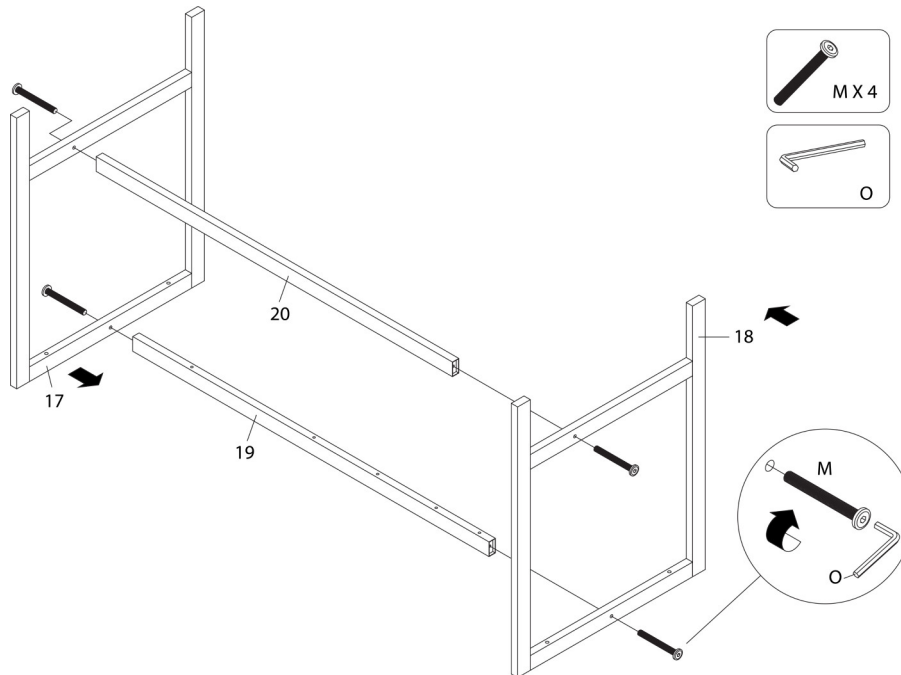

ÉTAPE / STEP 5

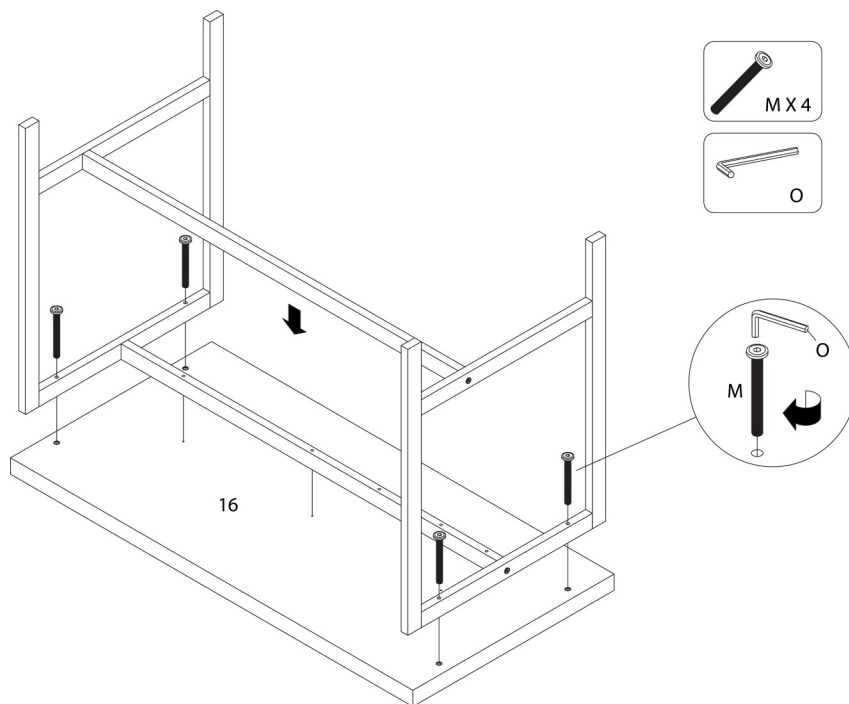

ÉTAPE / STEP 6

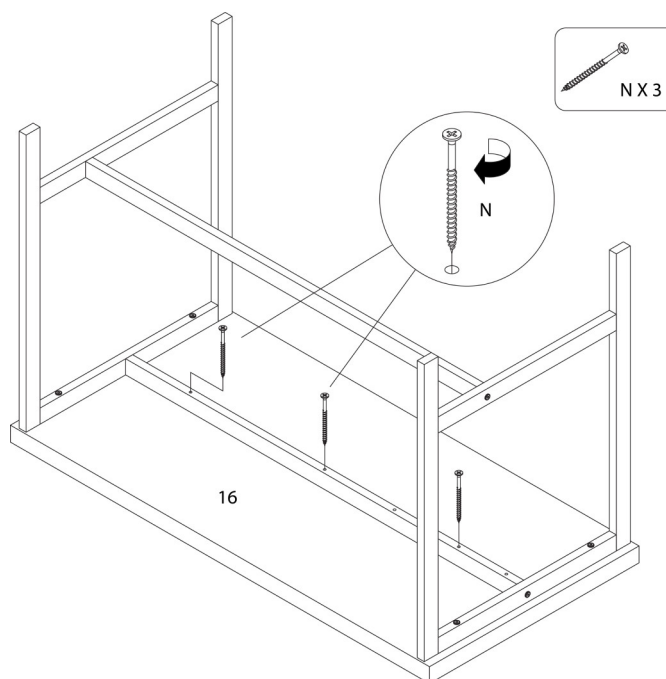

ÉTAPE / STEP 7

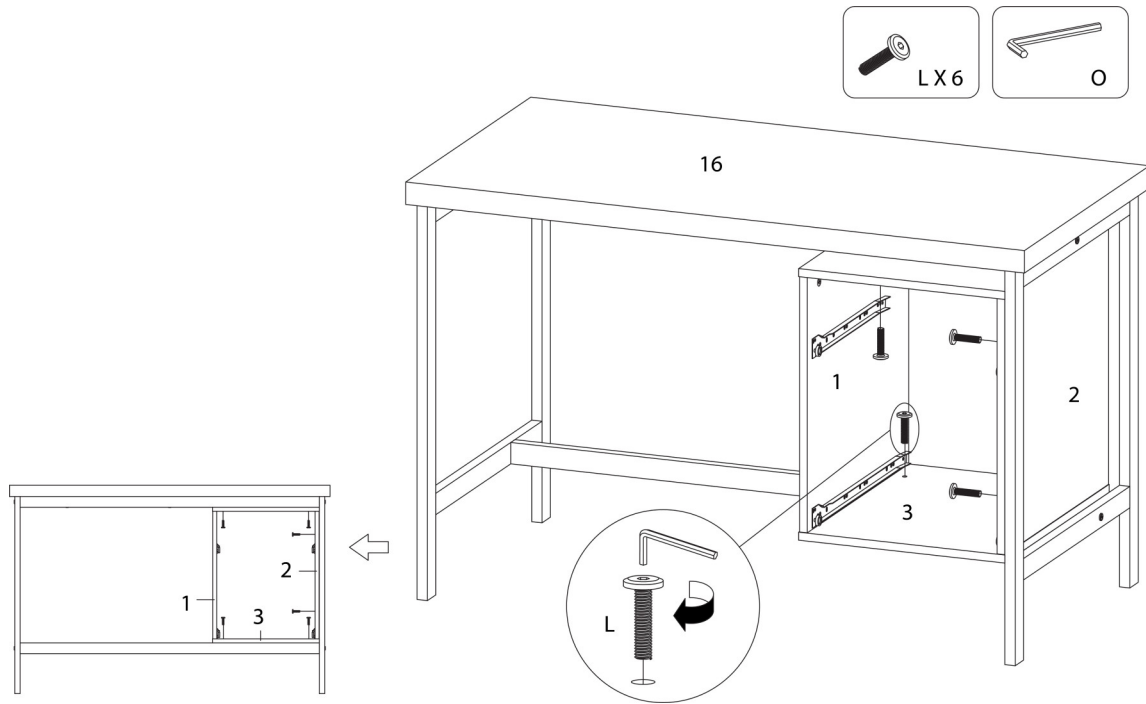

ÉTAPE / STEP 8

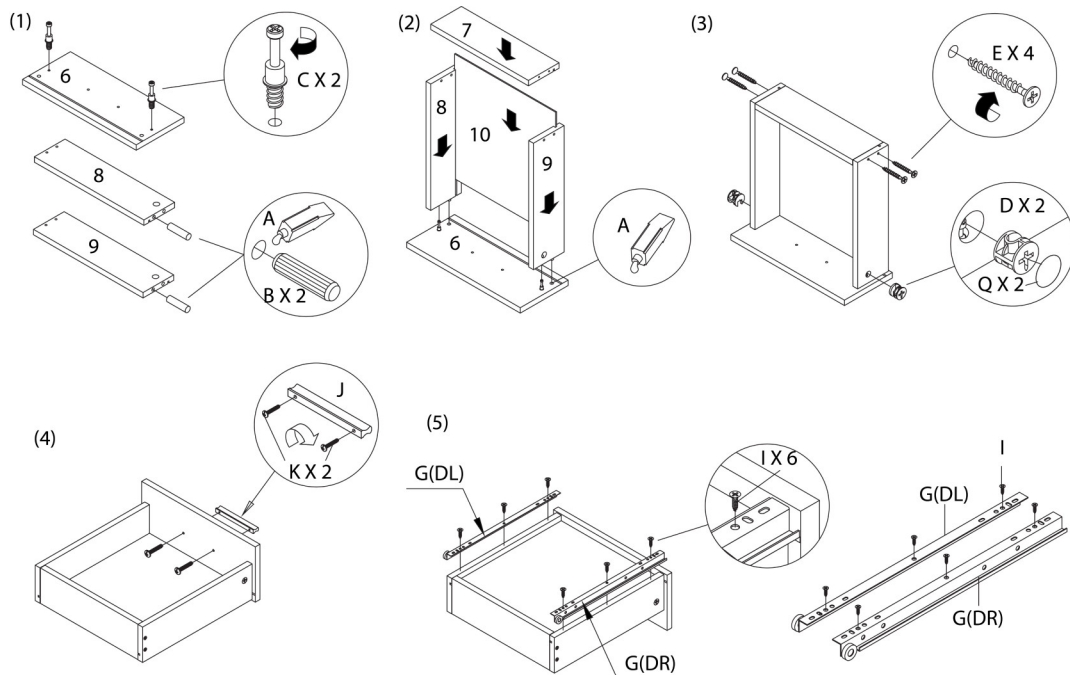

ÉTAPE / STEP 9

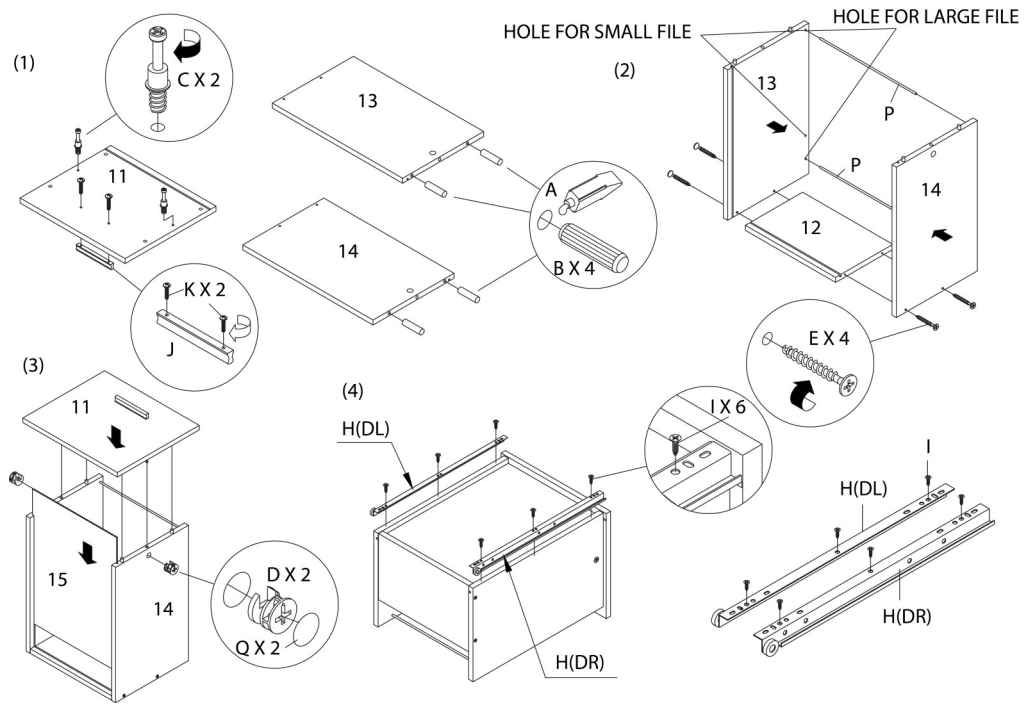

ÉTAPE / STEP 10

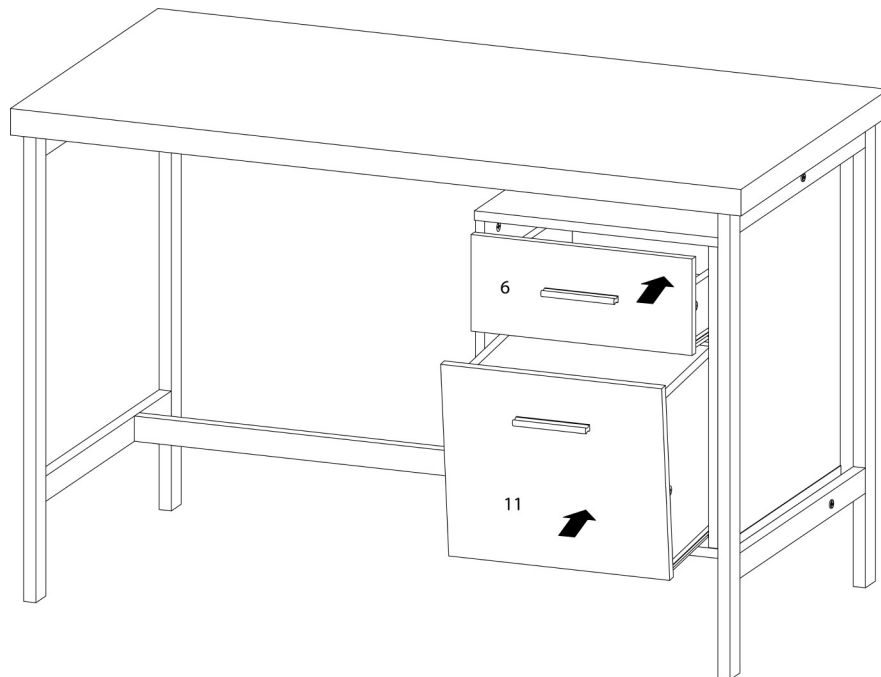

ÉTAPE / STEP 11

