

SOJAG

produits saisonniers • seasonal products

QUESTIONS? 1 866-901-1649

Assembly Manual / Guide d'assemblage / Manual de ensamblaje / 조립 설명서 / Montageanleitung

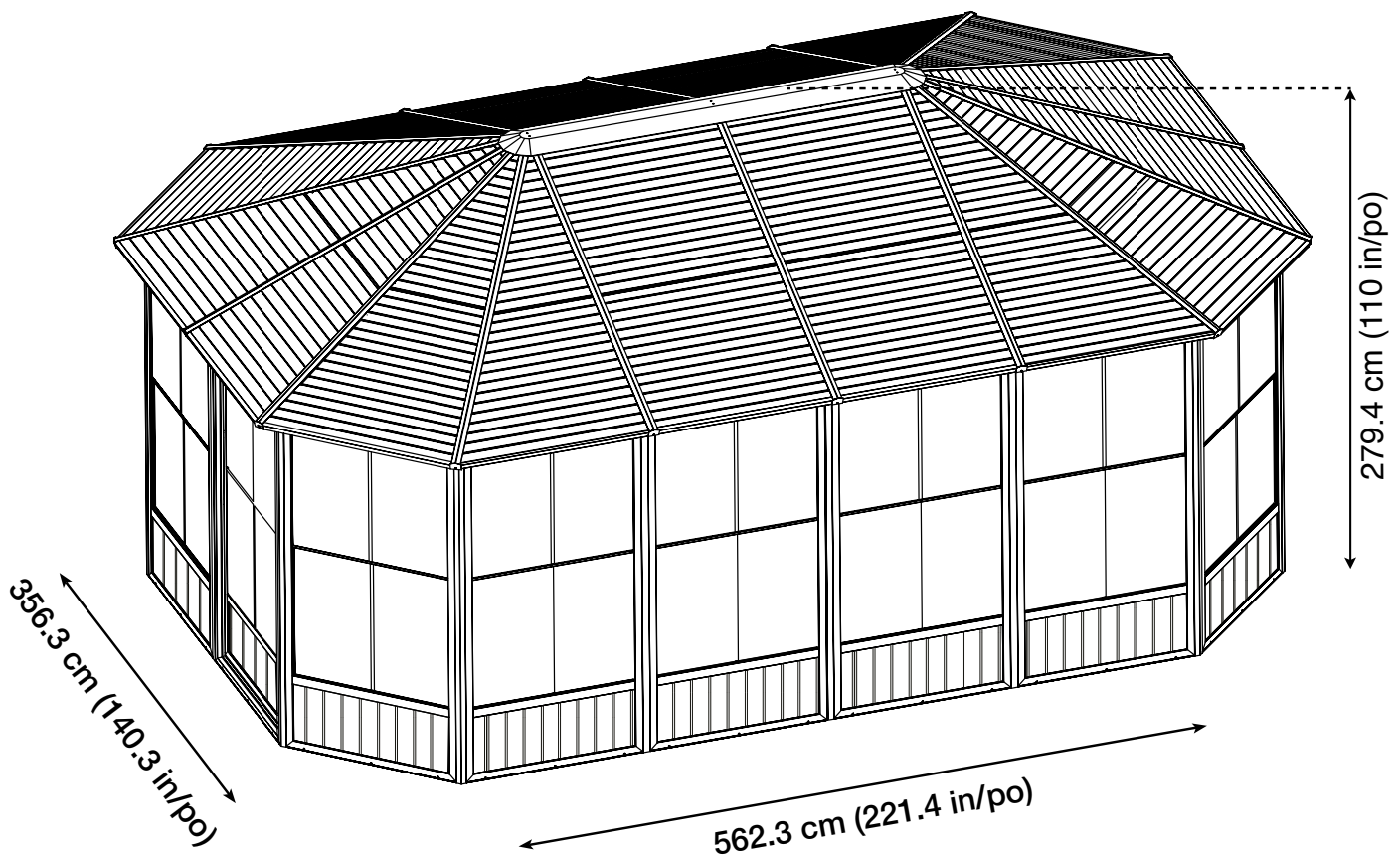

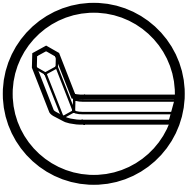

Use the hex keys in the box. / Utilisez les clés hexagonales fournies dans la boîte. /
Utilice las llaves hexagonales en la caja. / 상자에 육각 키를 사용 하십시오. / Verwenden Sie
die Sechskantschlüssel in der Box.

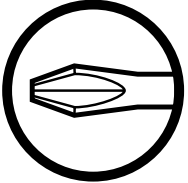

Please use a Phillips screwdriver. / Utilisez un tournevis de type Phillips / Por favor,
use un destornillador Phillips. / 십자 드라이버를 사용 하십시오. / Bitte verwenden
Sie einen Kreuzschraubenzieher.



You may need to use a drill for this step. / Vous pouvez avoir besoin d'utiliser une
perceuse pour cette étape. / Puede que tenga que utilizar un taladro para este paso. /
이 단계에선 드릴을 사용해야 할 수도 있습니다. / Für diesen Schritt können Sie einen
Bohrer verwenden.



Wearing protective gloves is recommended. / Le port de gants de protection est recommandé /
El uso de guantes de protección se recomienda. / 보호 장갑을 착용 하는 것이 좋습니다. /
Das Tragen von Schutzhandschuhen wird empfohlen.



Two or more people are required at this stage. / Deux personnes ou plus sont nécessaires à cette
étape. / Dos o más personas se requieren en esta etapa. / 이 단계에서는 두 명 이상 이 필요합니다. /
Für diesen Bauschritt sind 2 oder mehr Personen erforderlich.



Do not tighten screws all the way for now. / Ne pas visser fermement pour l'instant. /
No atornille con firmeza por ahora. / 아직 나사를 단단히 조이지 마십시오. / Bitte die
Schrauben zum jetzigen Zeitpunkt noch nicht fest anziehen.



Sold separately. / Vendus séparément. / vendido en las opciones. /
옵션 판매 / Optional erhältlich

R X 16 (+4)

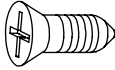

S X 32 (+4)



S1 X 16 (+2)



T X 40 (+6)

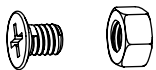

U X 80 (+8)

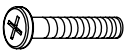

V X 74 (+8)

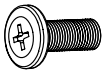

W X 24 (+3)

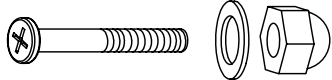

X X 3



V1 X 3 (+1)

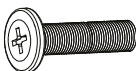

Y X 1

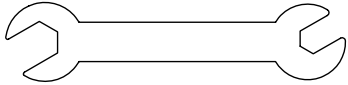

A X 12

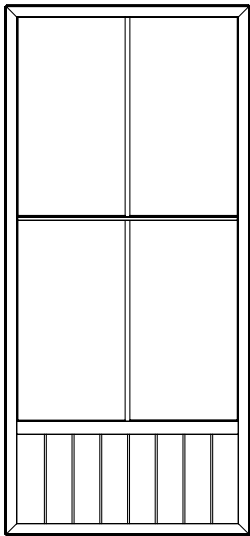

A1 X 2

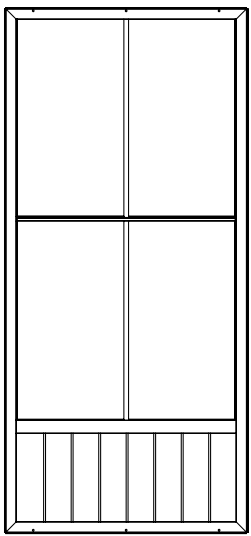

B X 2

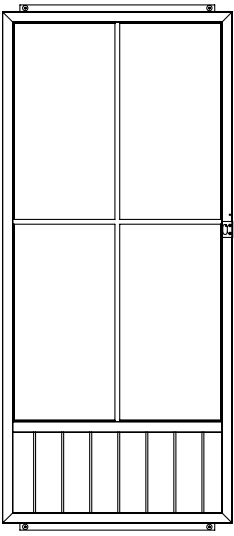

B1 X 2

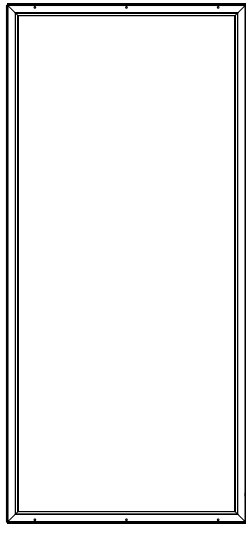

C X 16



D X 4



D1 X 8

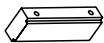

E X 8



E1 X 8



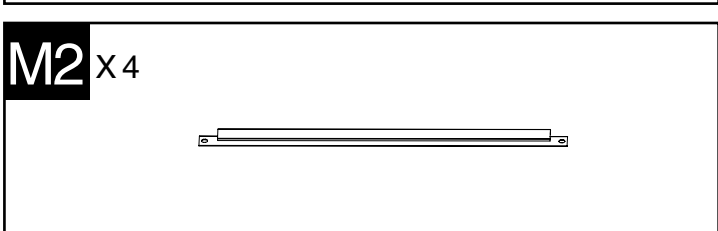
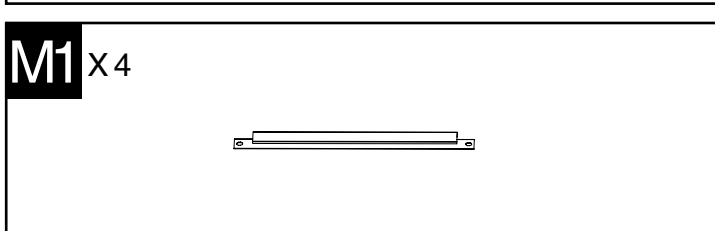
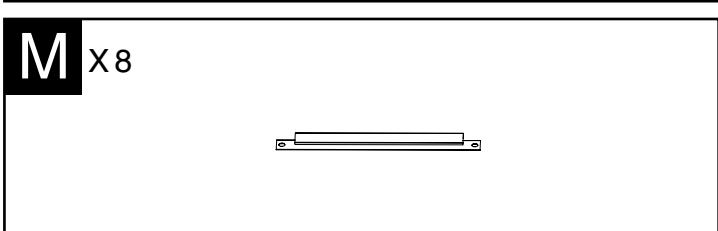
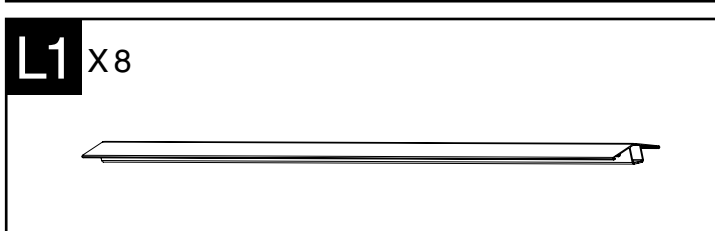
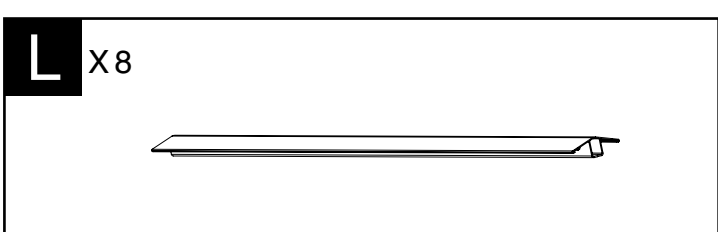
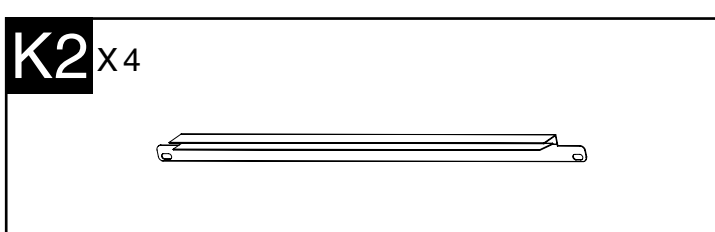
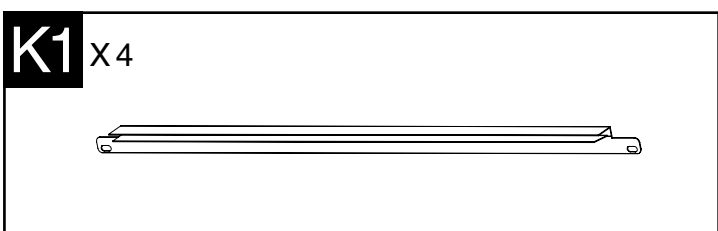
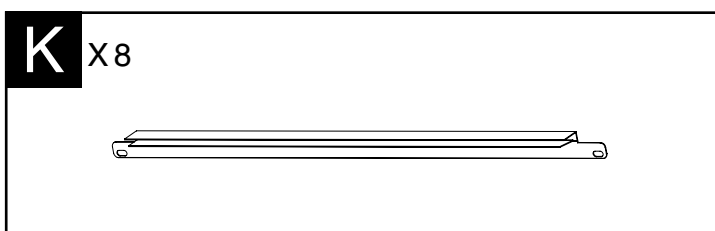
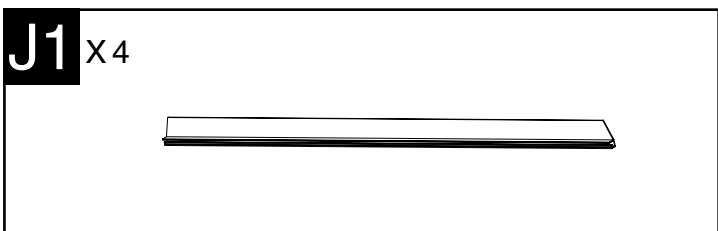
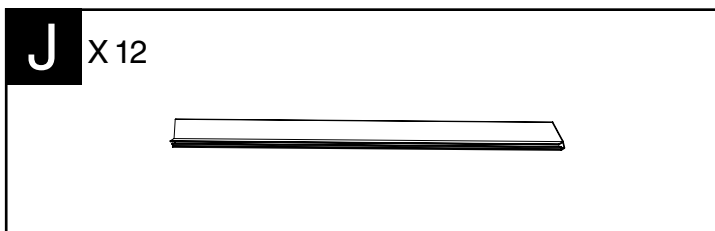
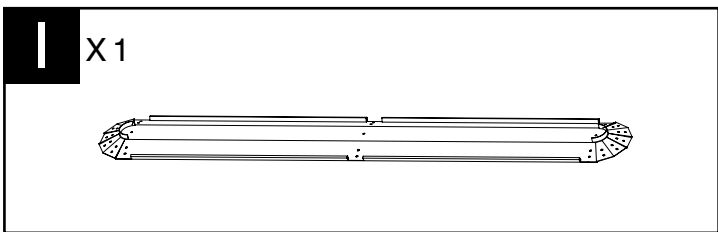
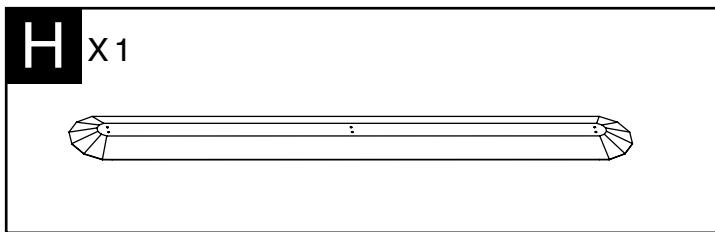
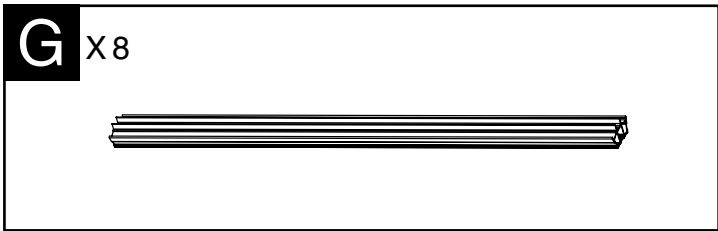
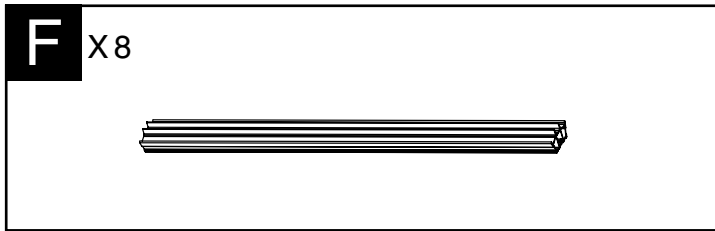

B3 x8

N x8

O x8

P x16

Q x2

Qa x4

Qb x4

Qc x4

Ra x4

Rb x4

R1a x4

R1b x4

Sa x4

Sb x4

Z x3

Winter Bar / Barre hivernale Ajustable

X2

X2

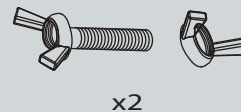
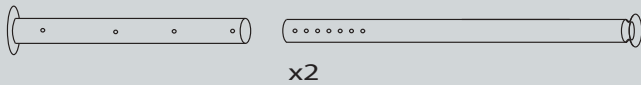
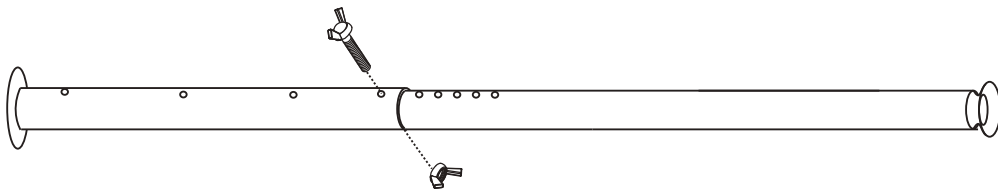
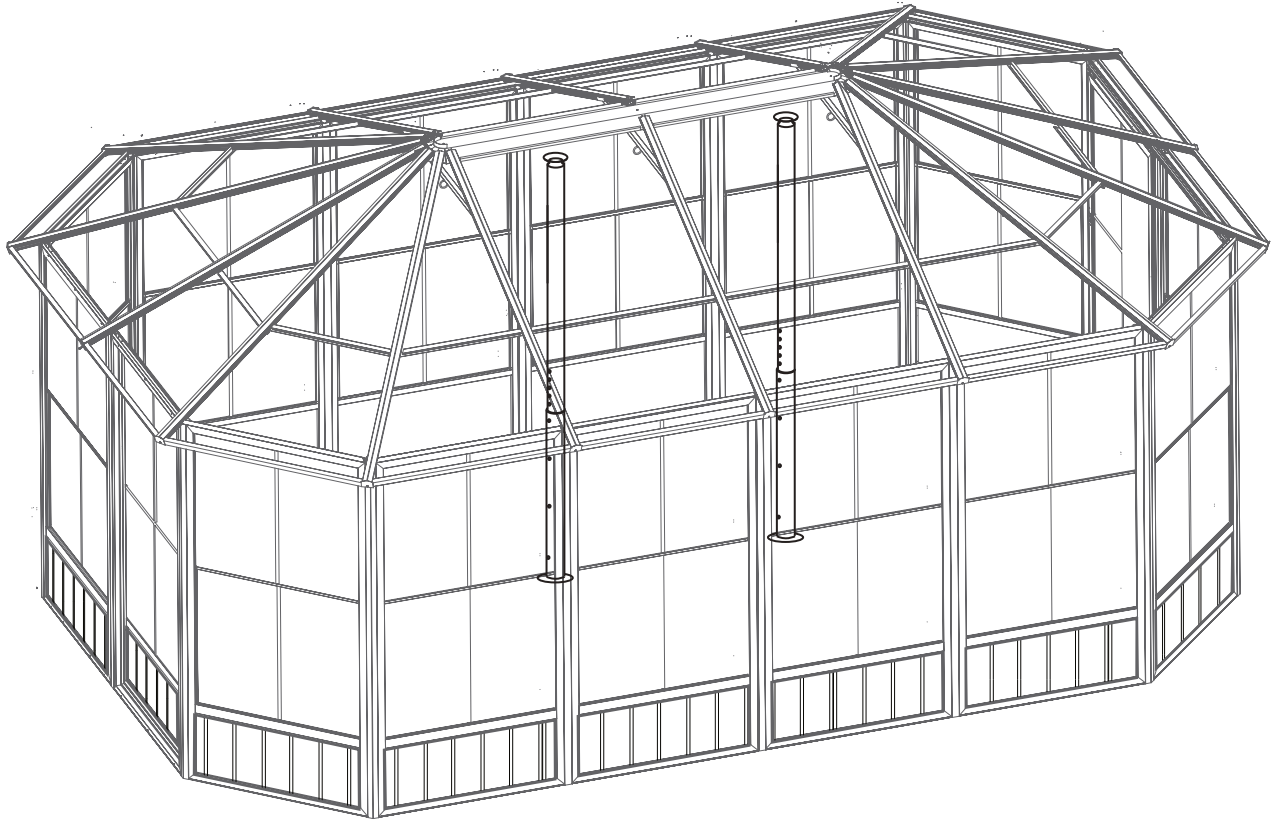
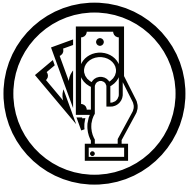

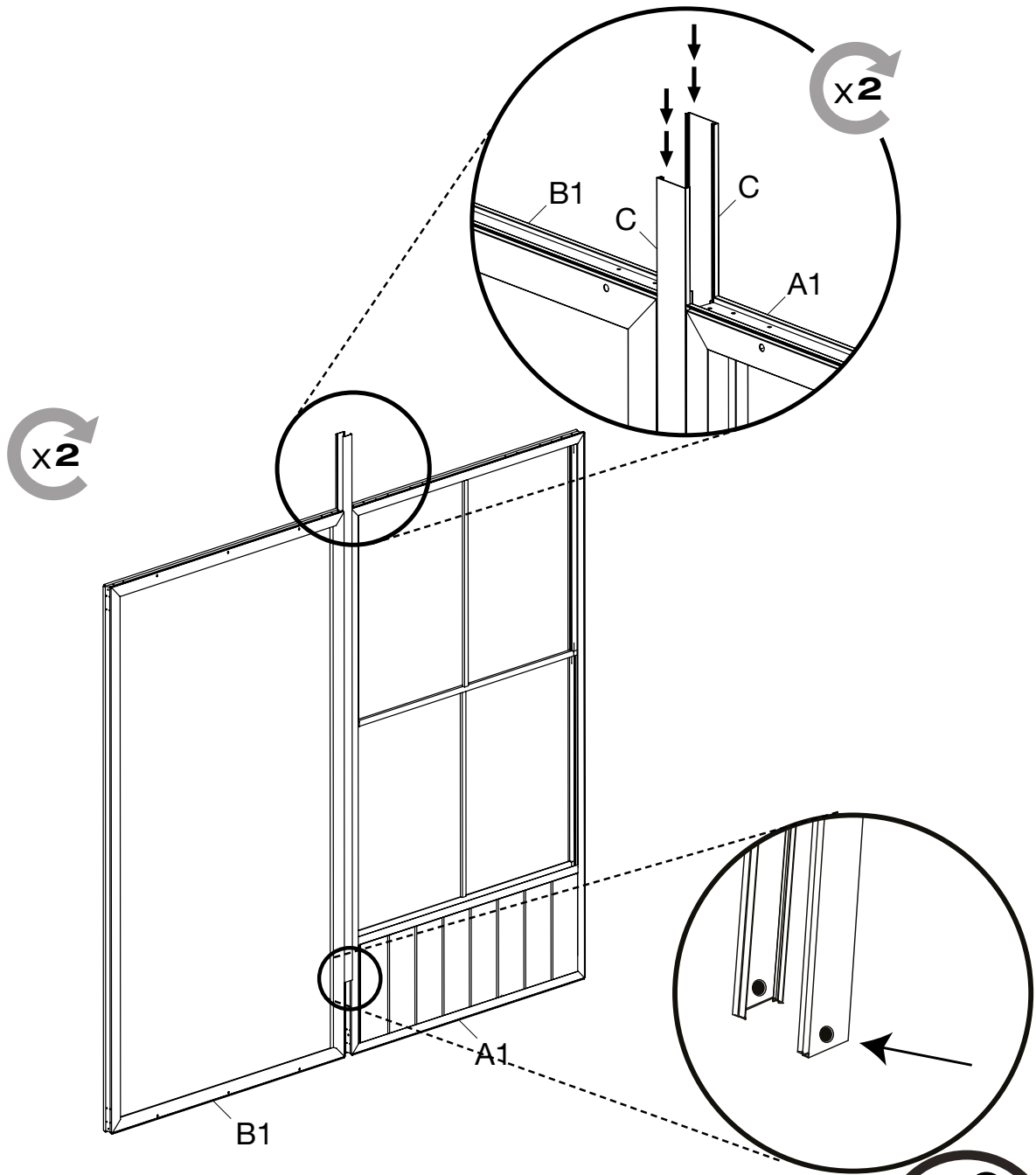

This section contains a parts list and an icon. On the left, there are two window icons: one with a grid pattern labeled 'A1x2' and one with a solid frame labeled 'B1x2'. In the center, there is a long horizontal bar labeled 'Cx4'. On the right, there is a circular icon containing two stylized human figures and the text '2+', indicating that two people are required for installation.

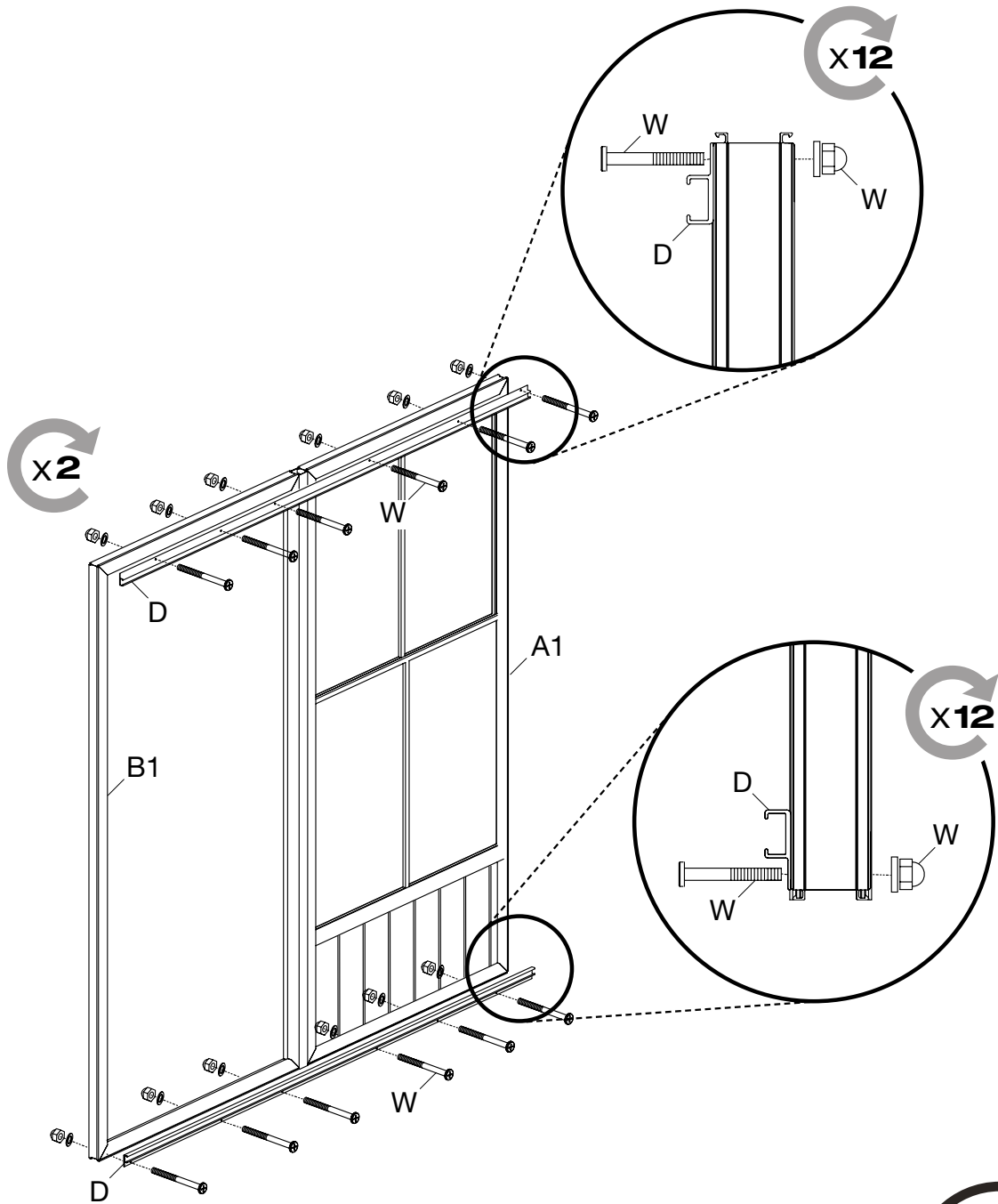

This section contains a parts list and an icon. On the left, there is a bolt labeled **Wx24**, a washer, and a nut. In the center, there is a long, thin metal bar labeled **Dx4**. On the right, there is a circular icon containing two stylized human figures and the text **2+**, indicating that two or more people are required for this step.

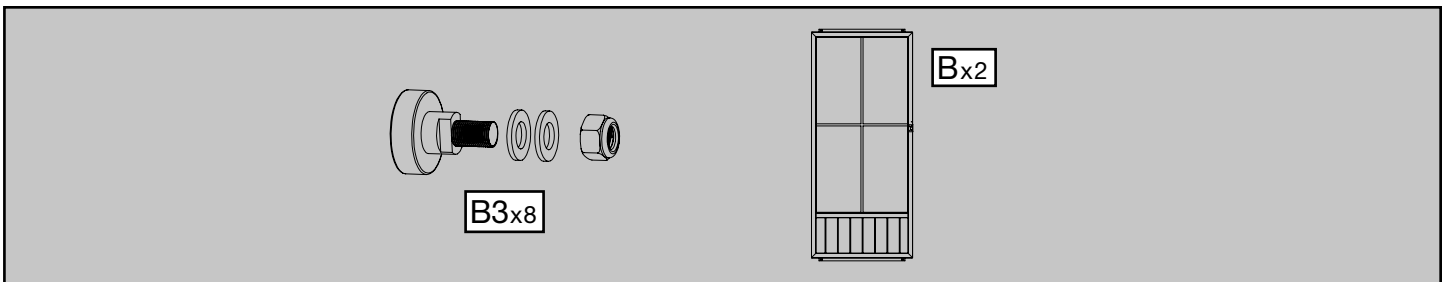
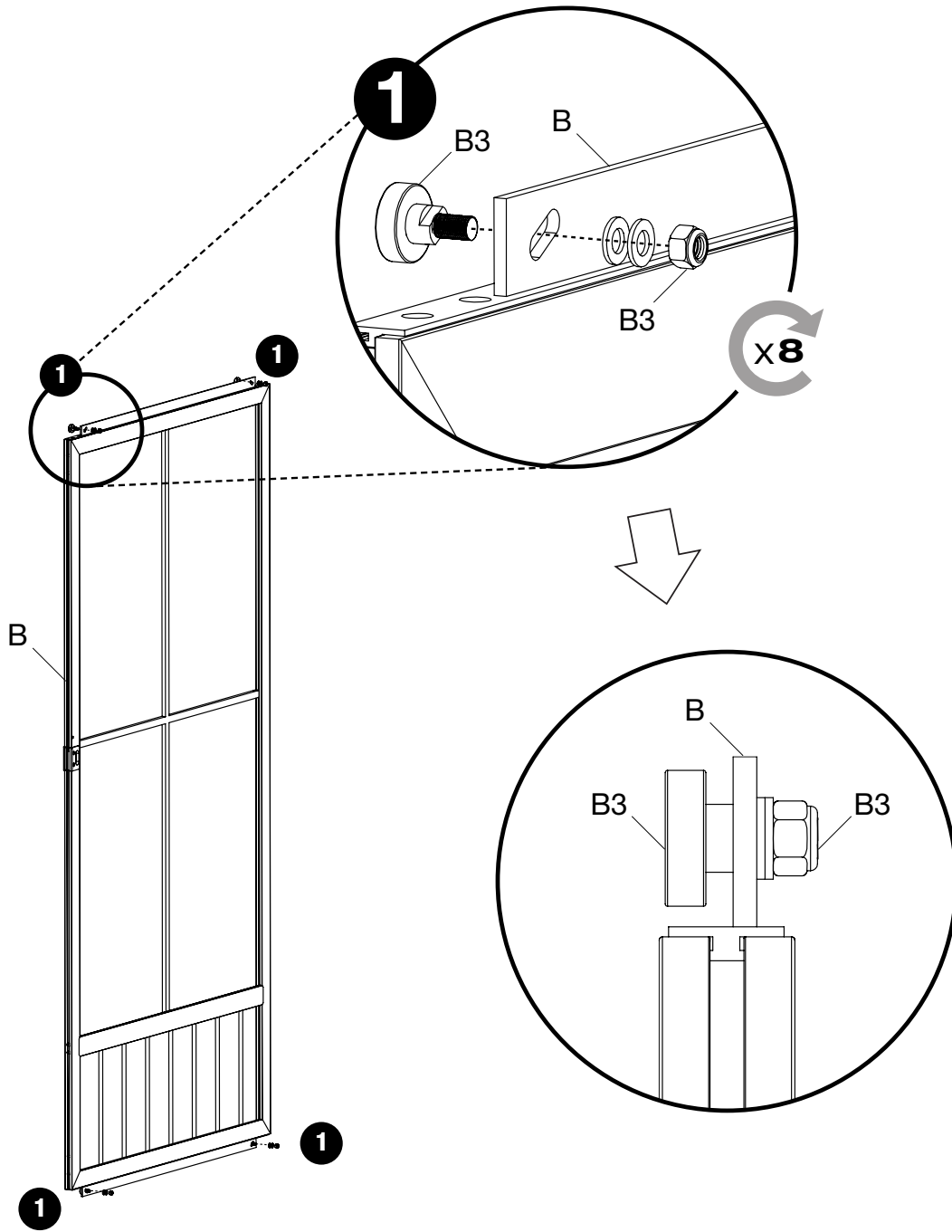

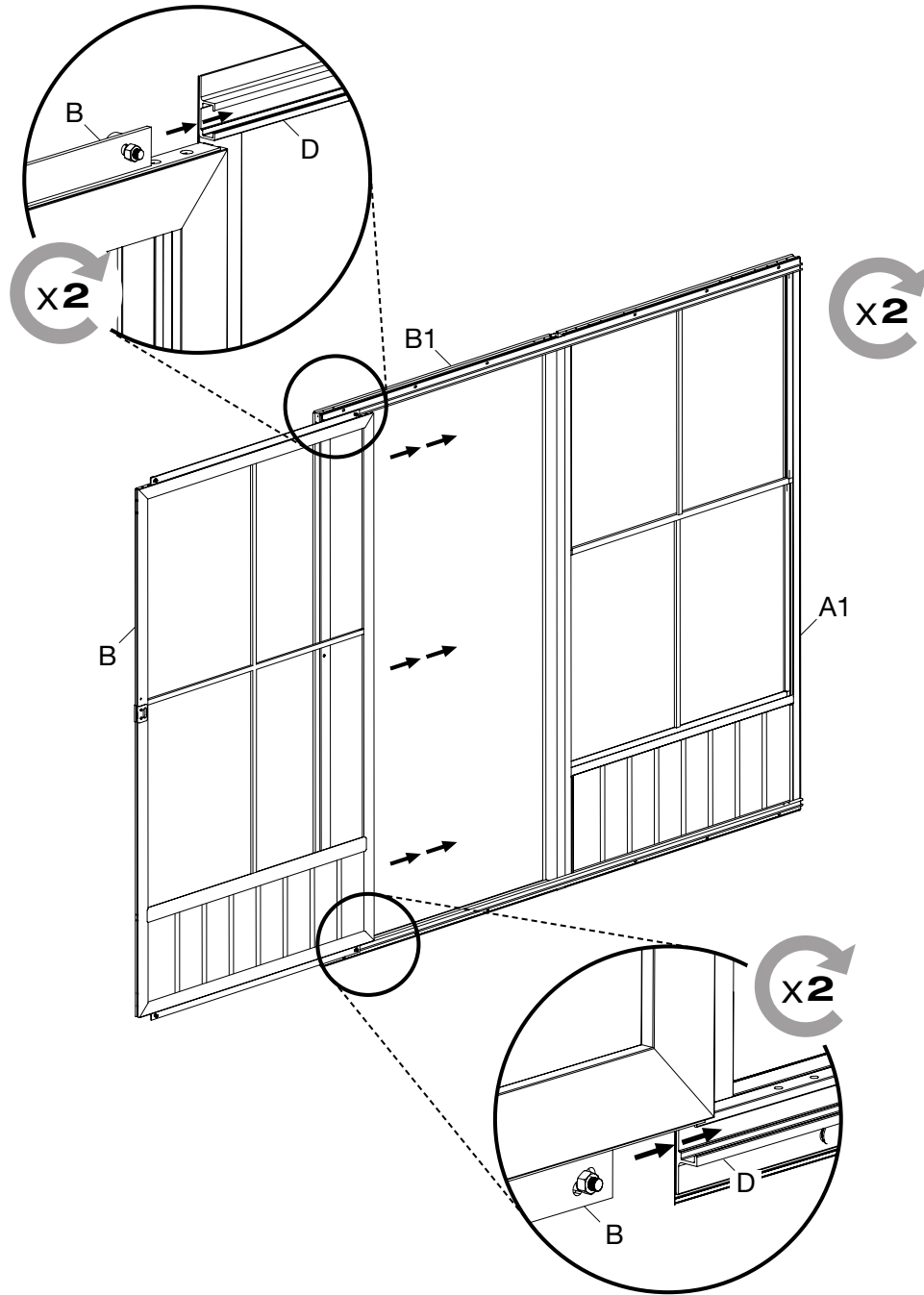

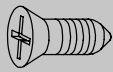
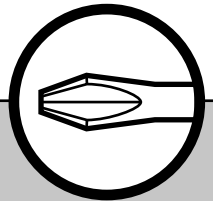
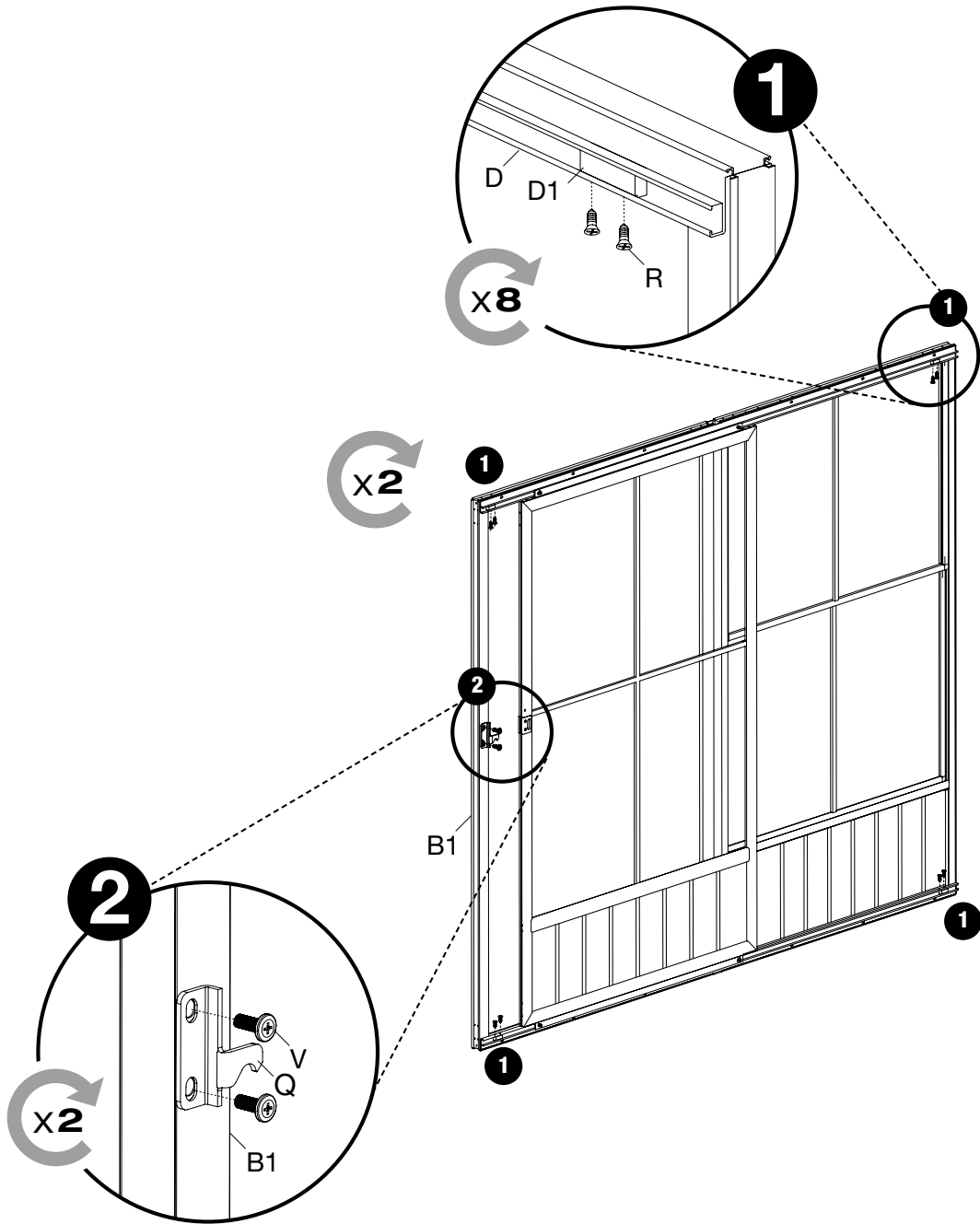

Rx16

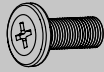

Vx4

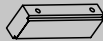

D1x8

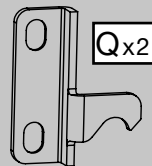

Qx2

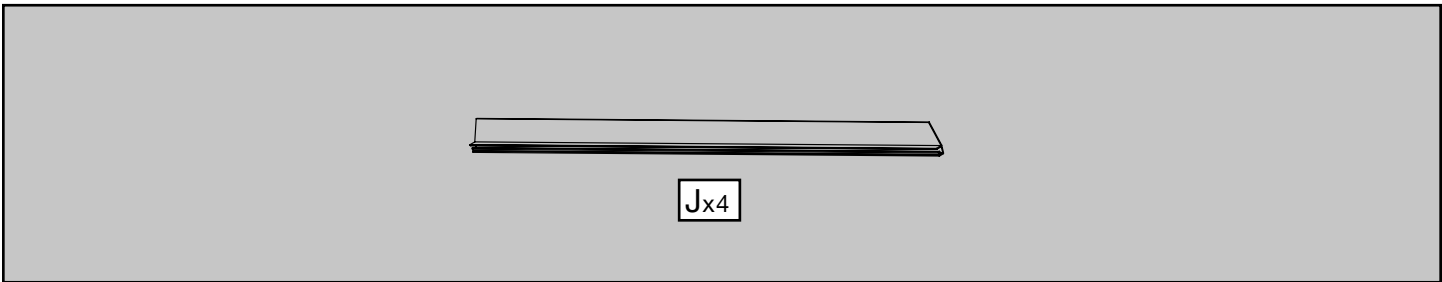
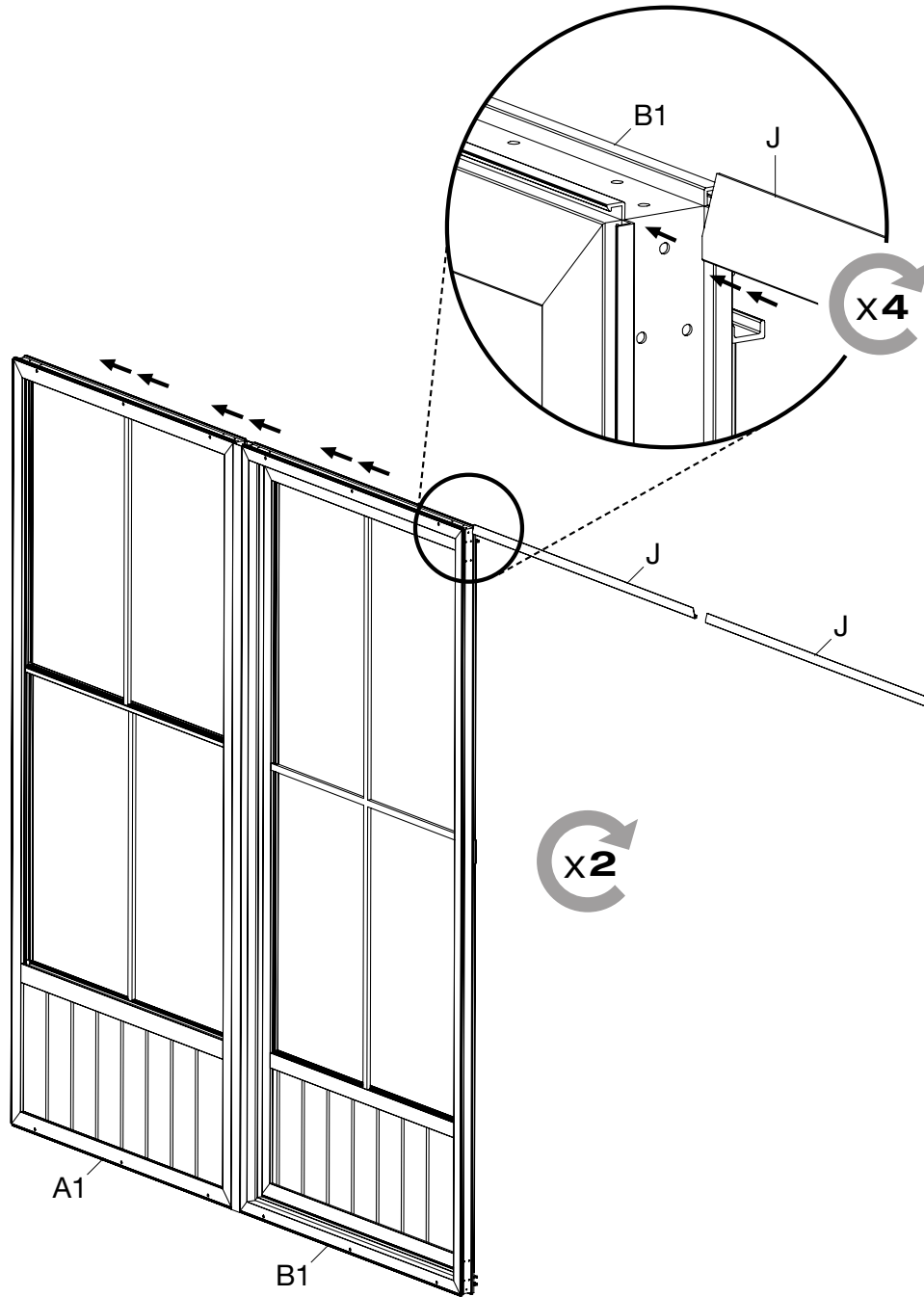

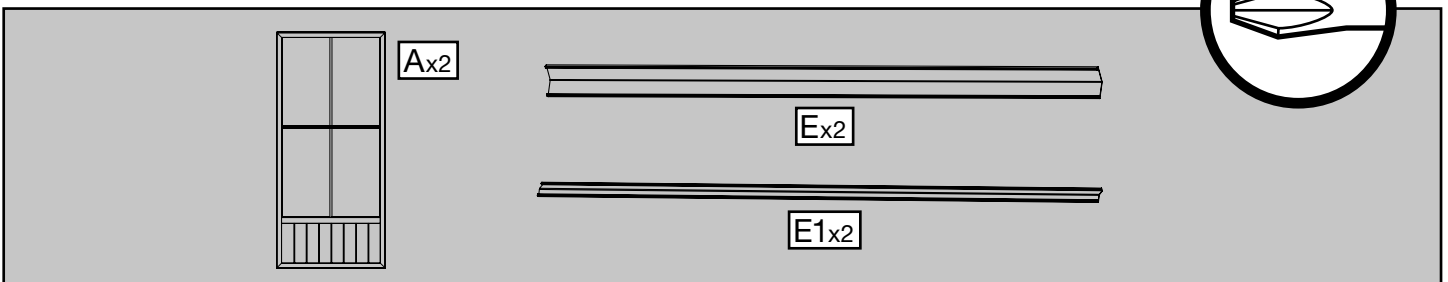
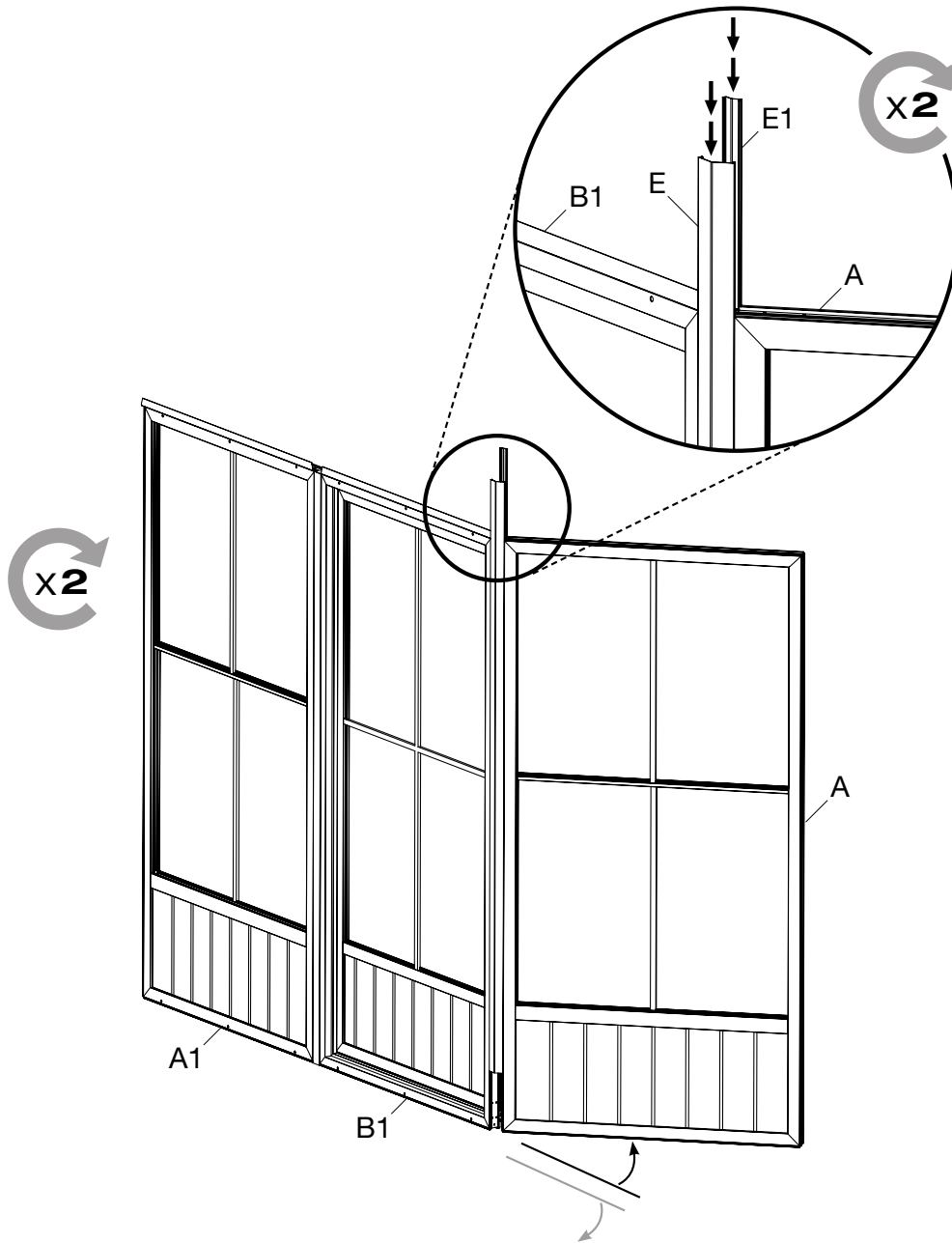

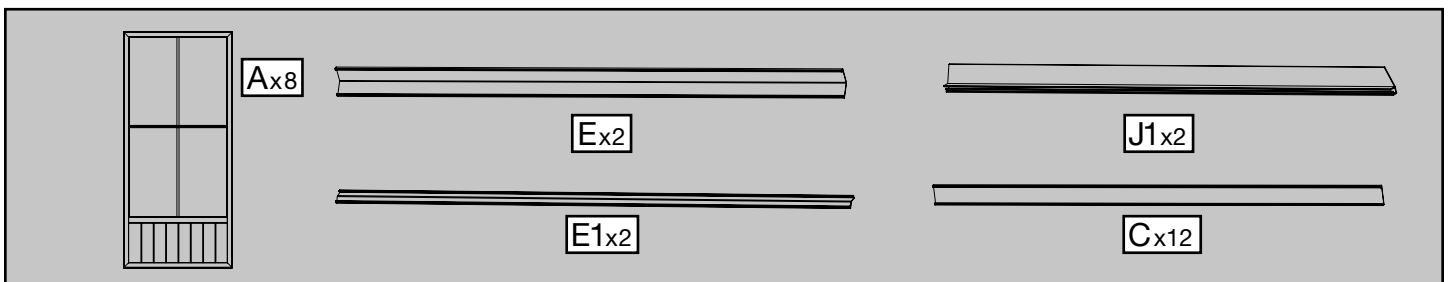
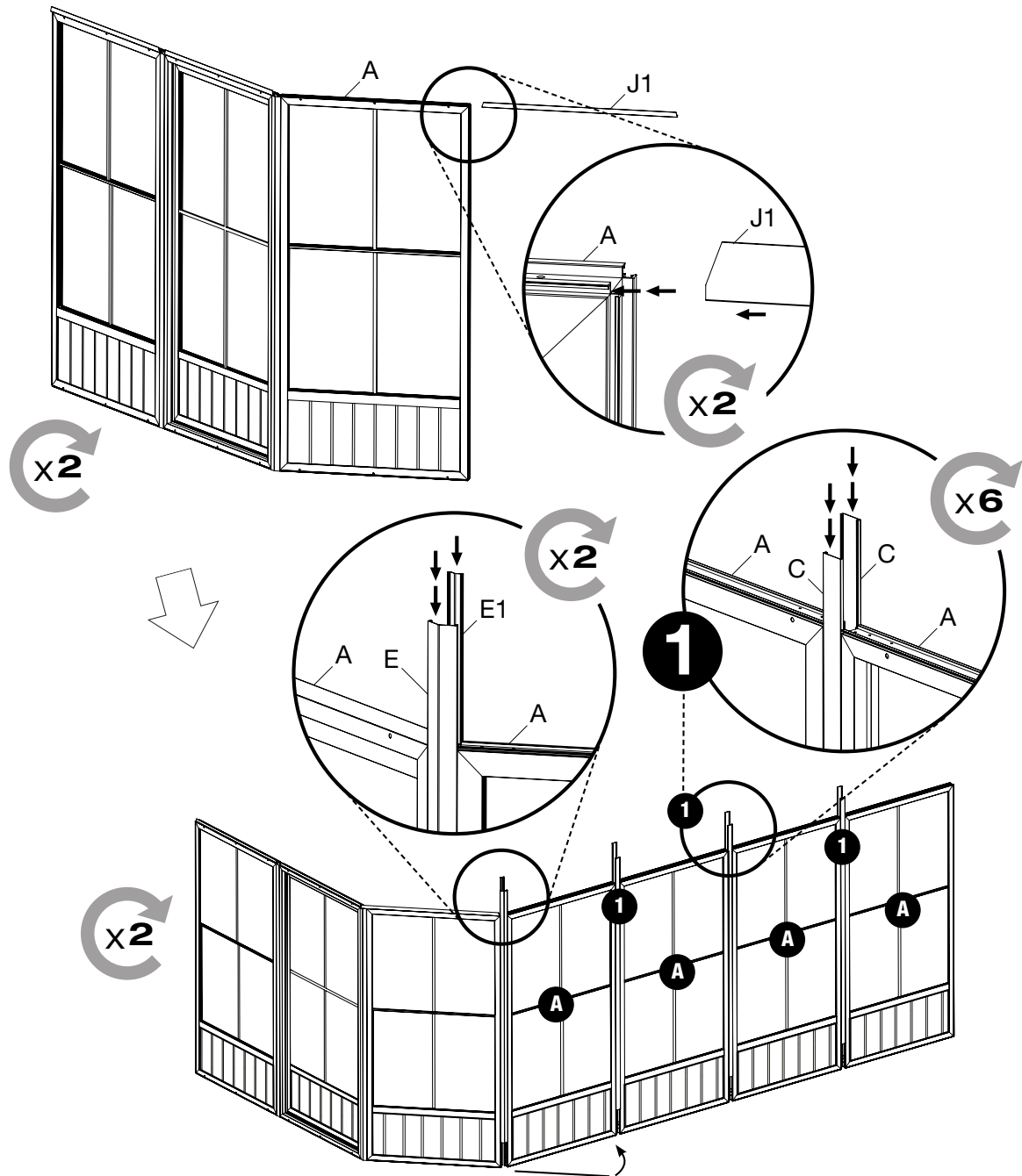

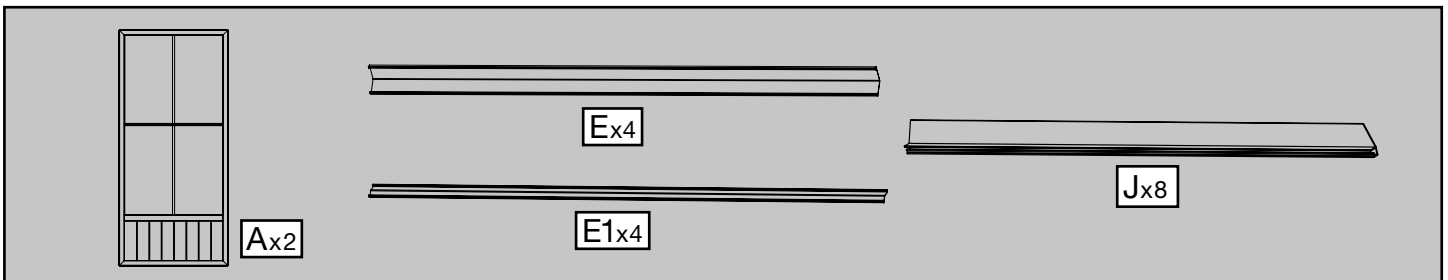
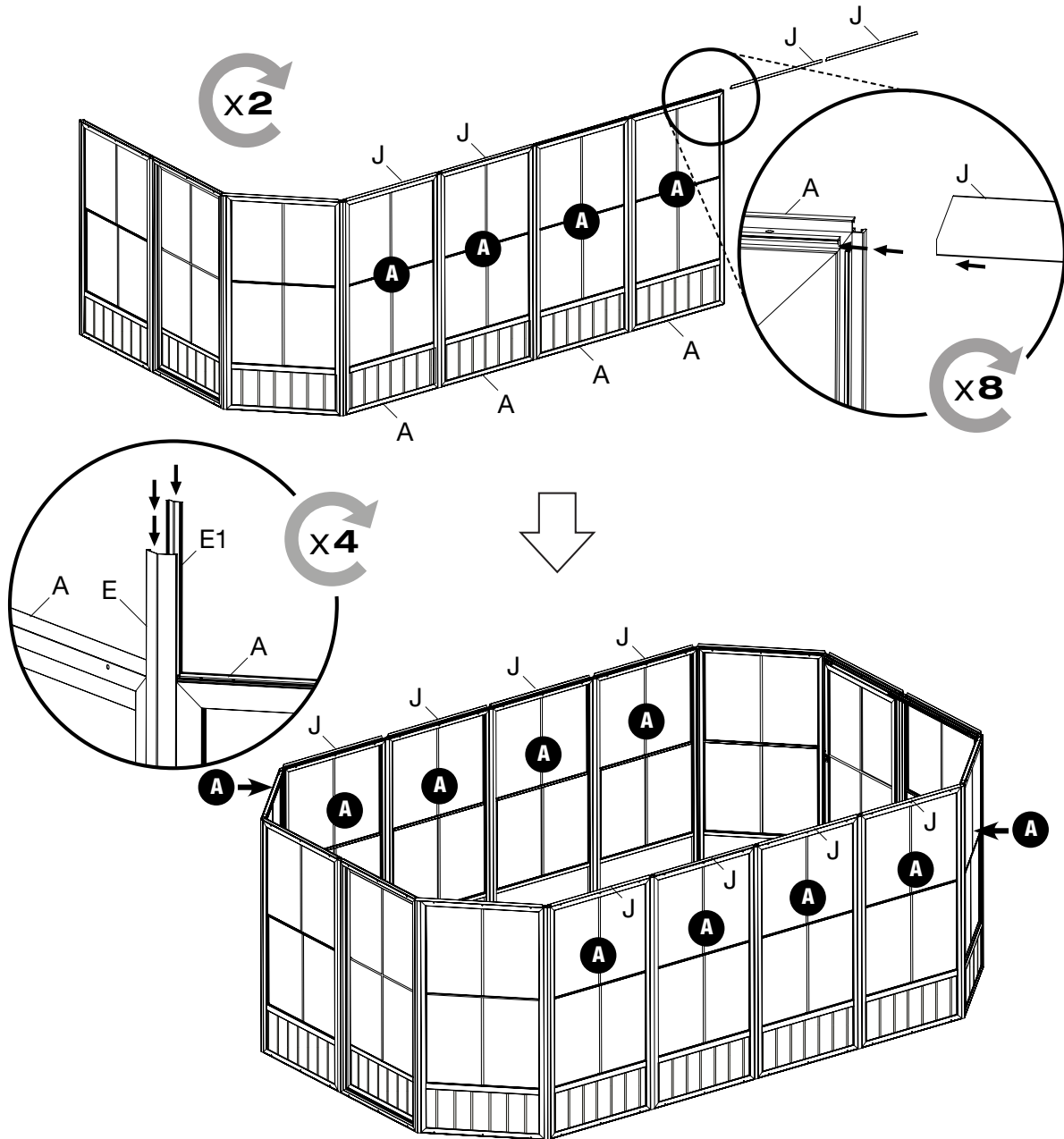

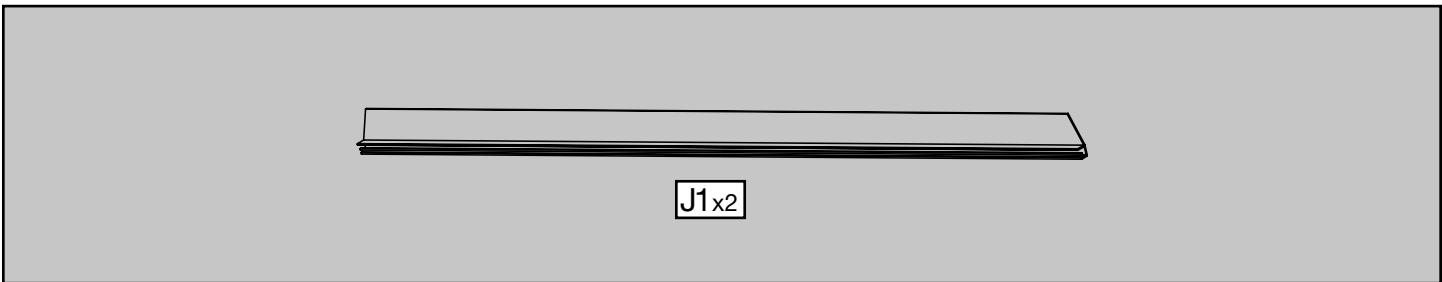
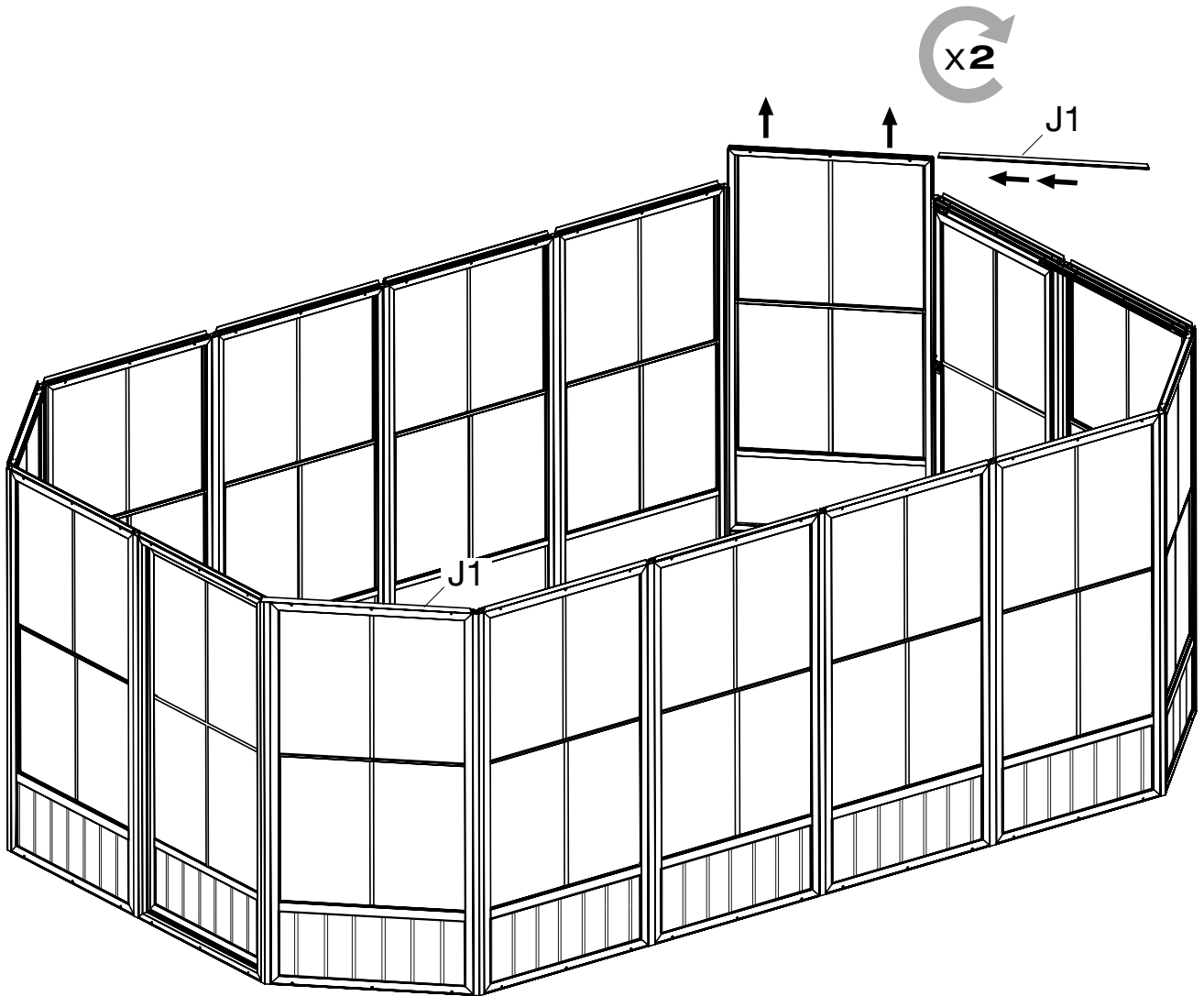

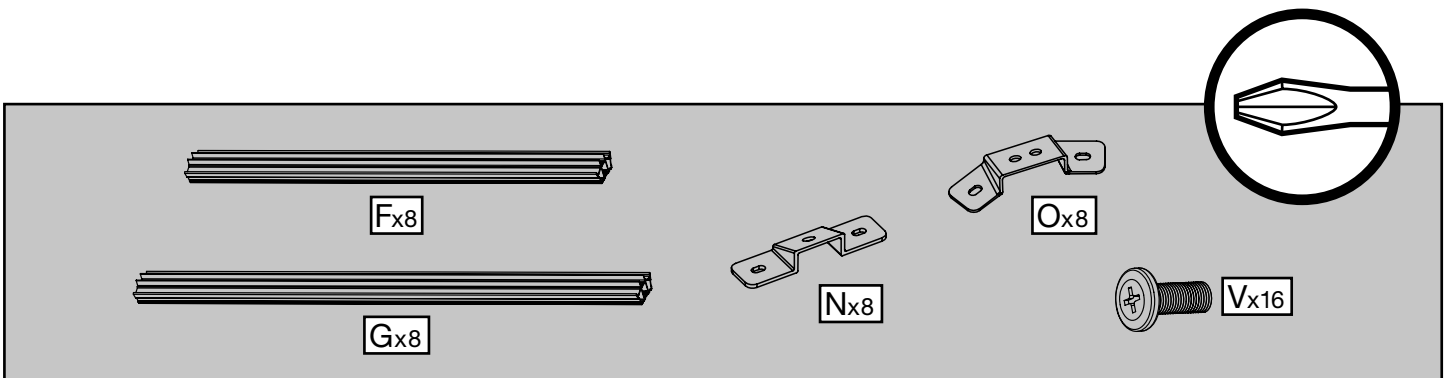
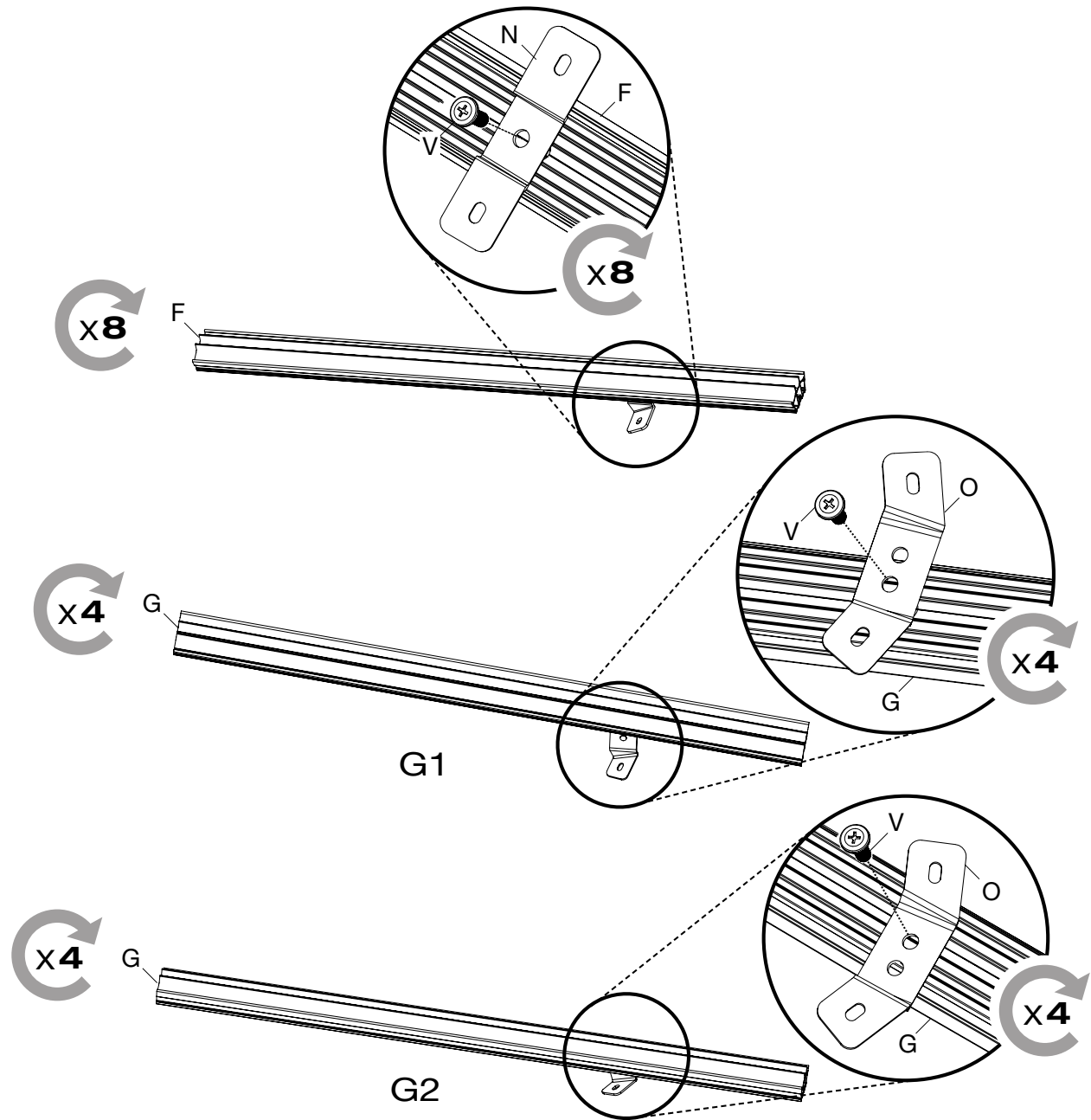

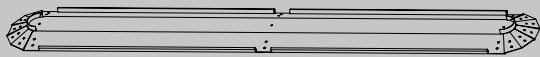
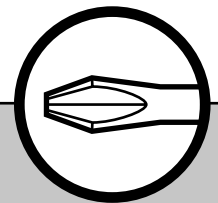
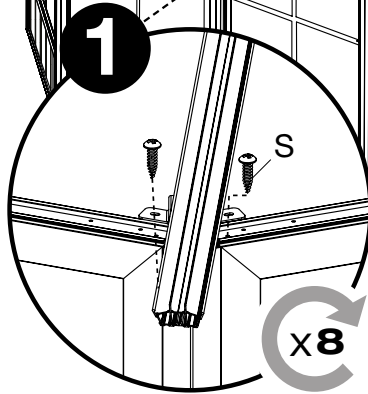
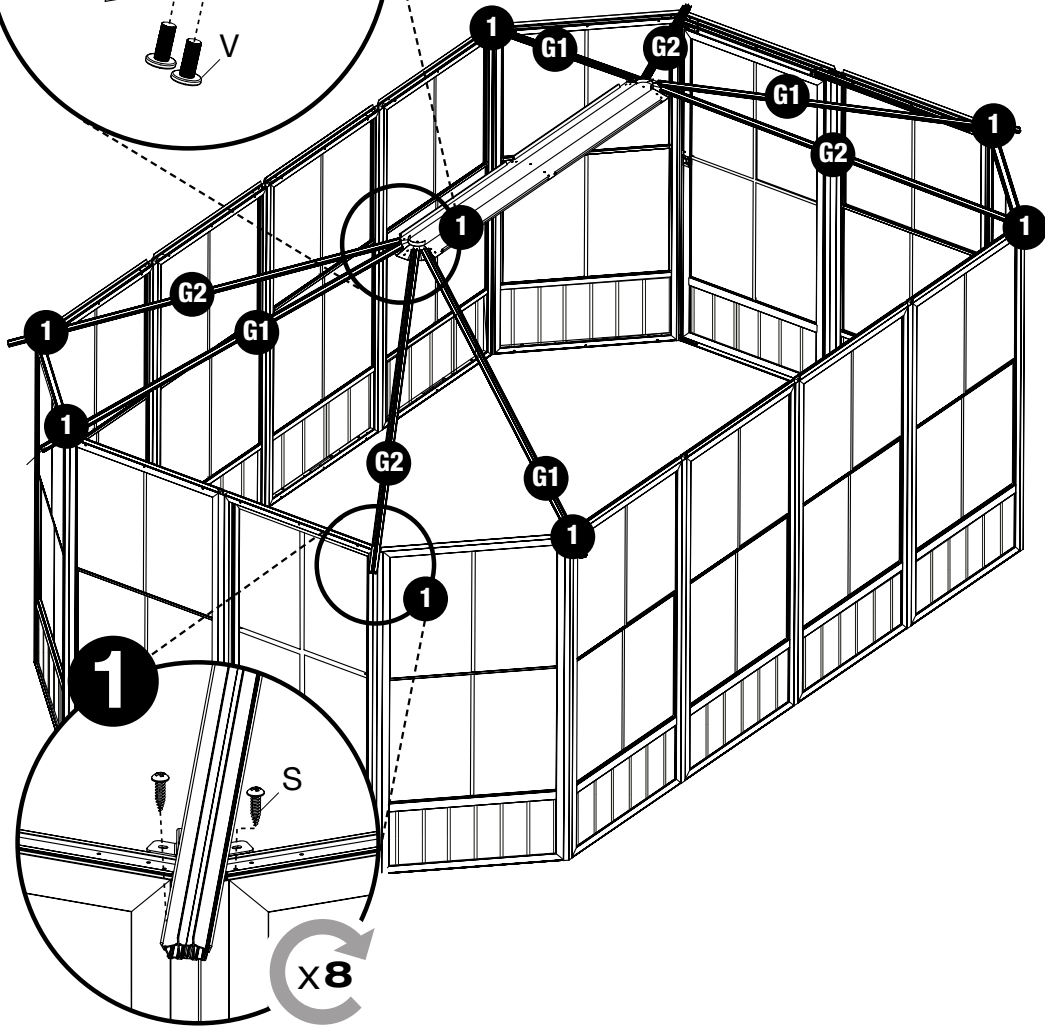
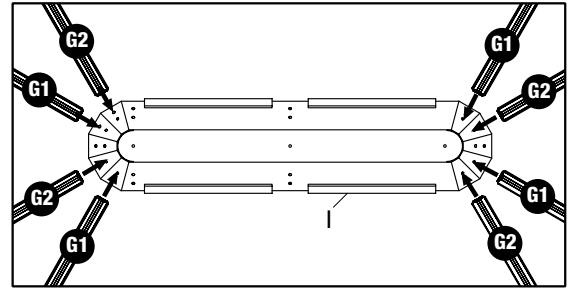
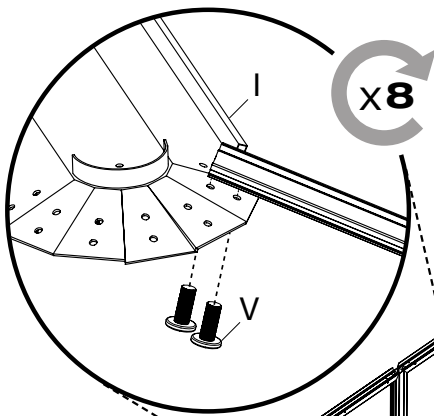

Ix1



Sx16

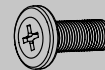

Vx16

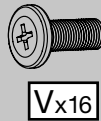
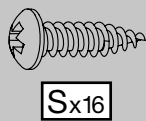
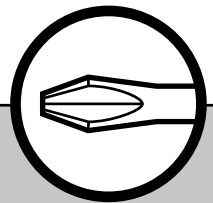
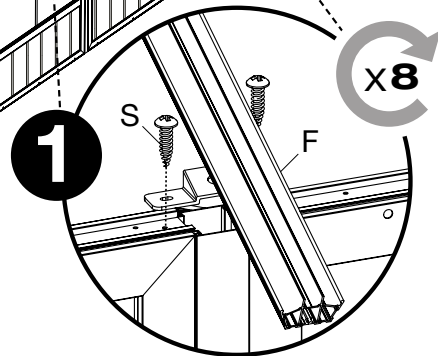
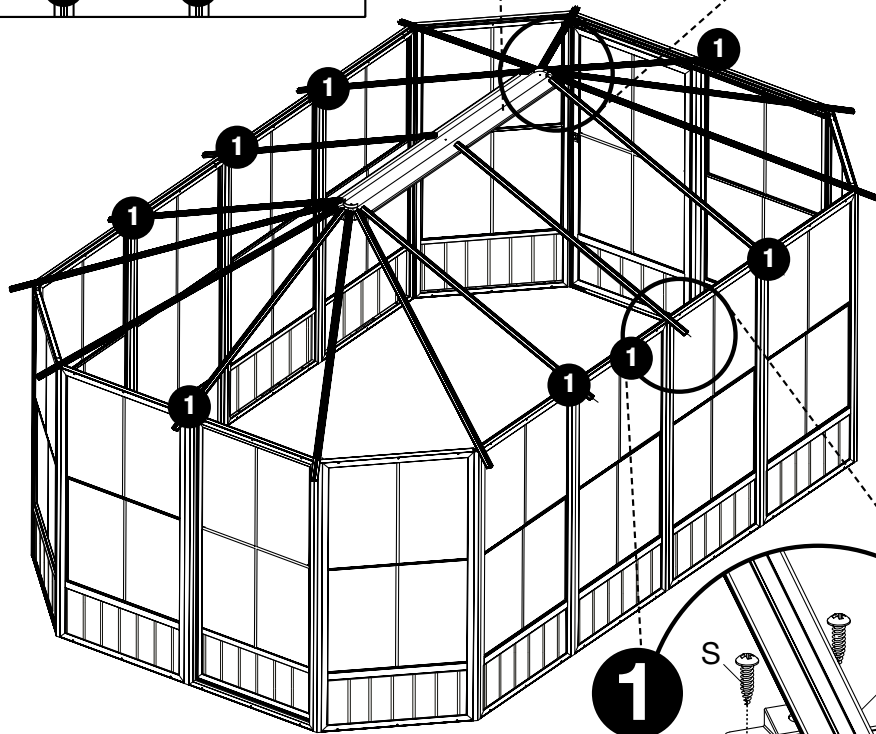
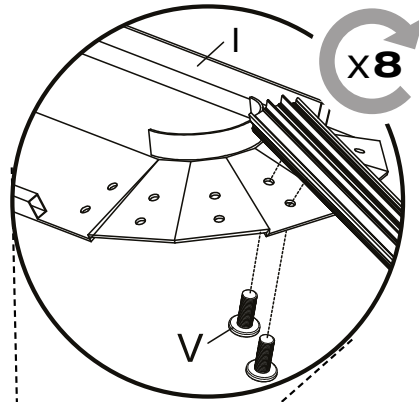
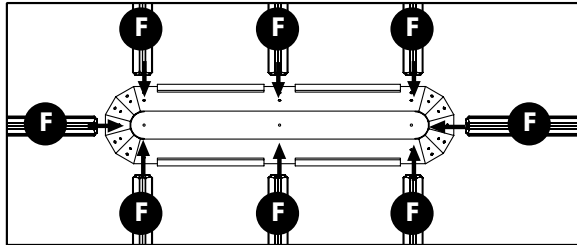

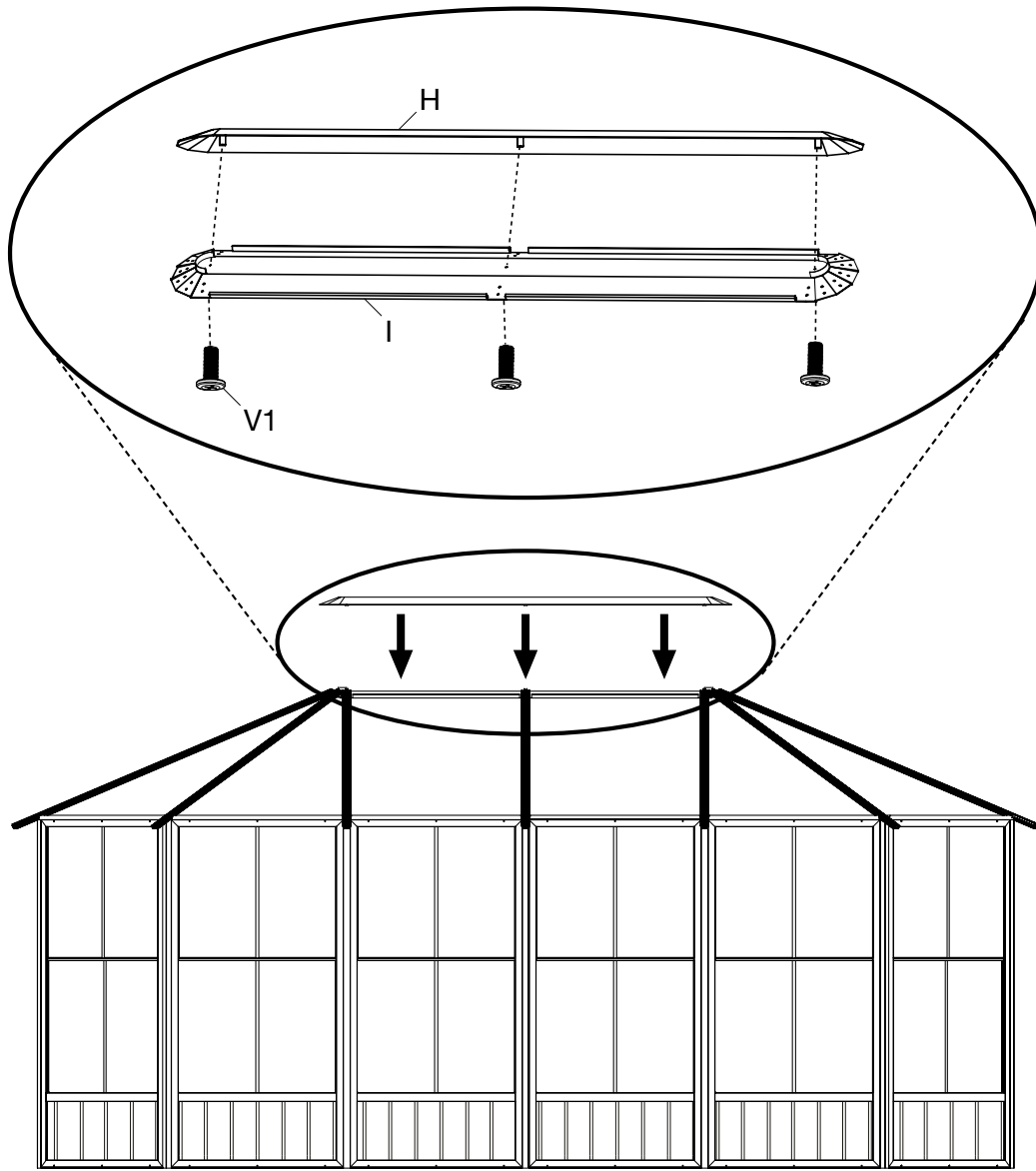

Hx1 **V1x3**

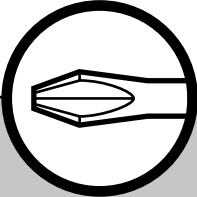

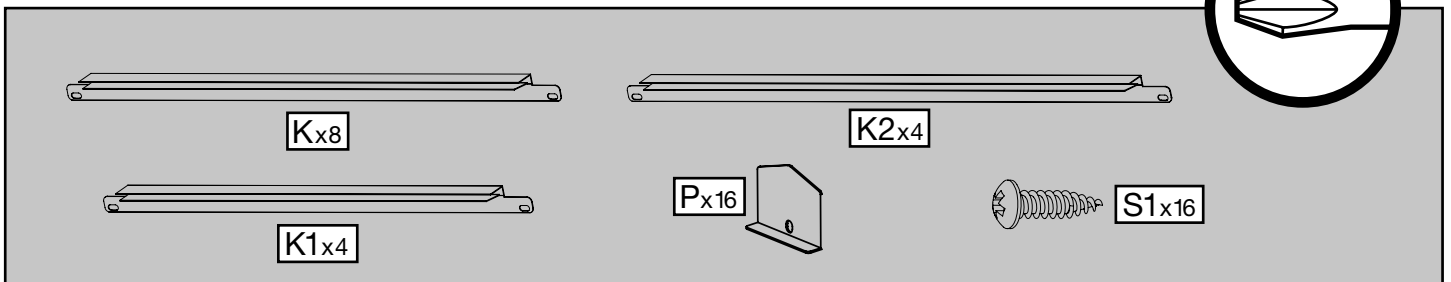
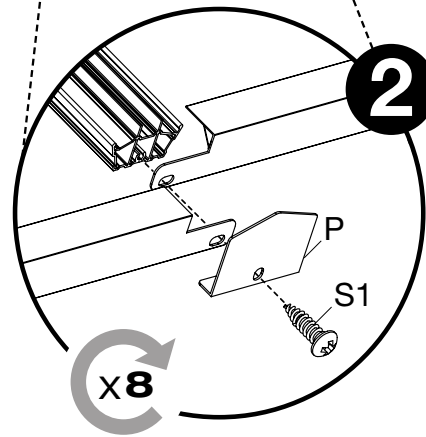
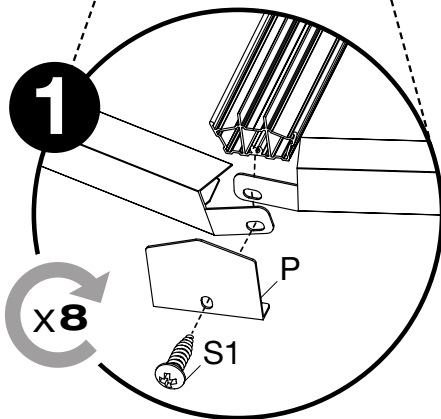
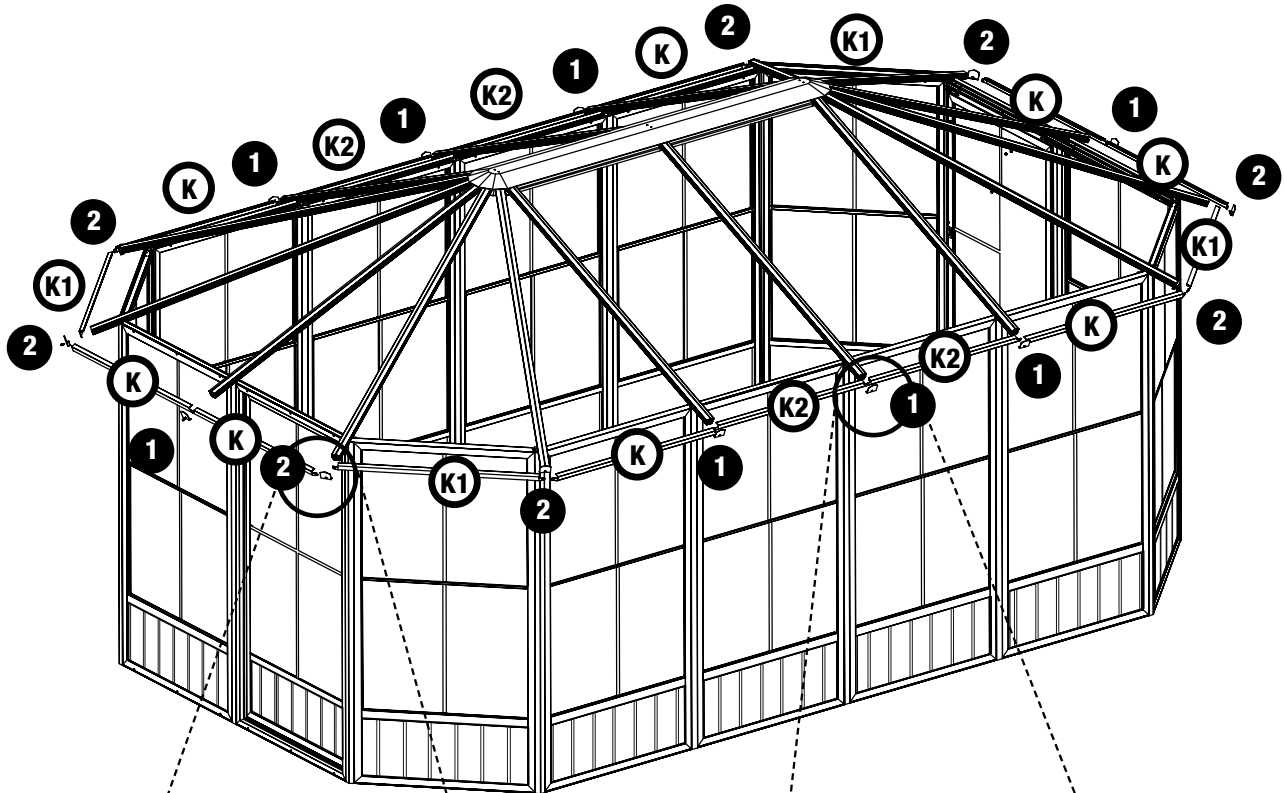

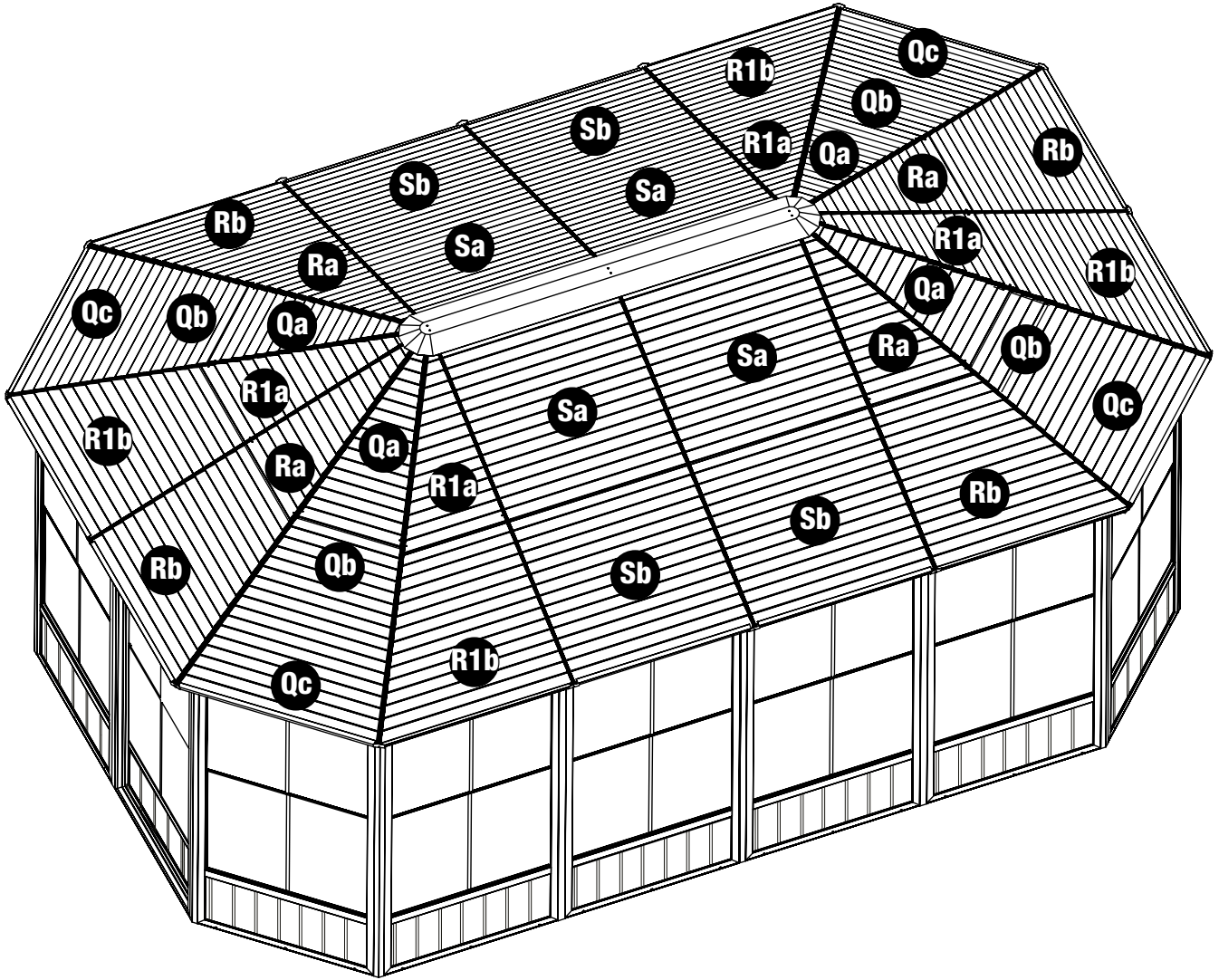

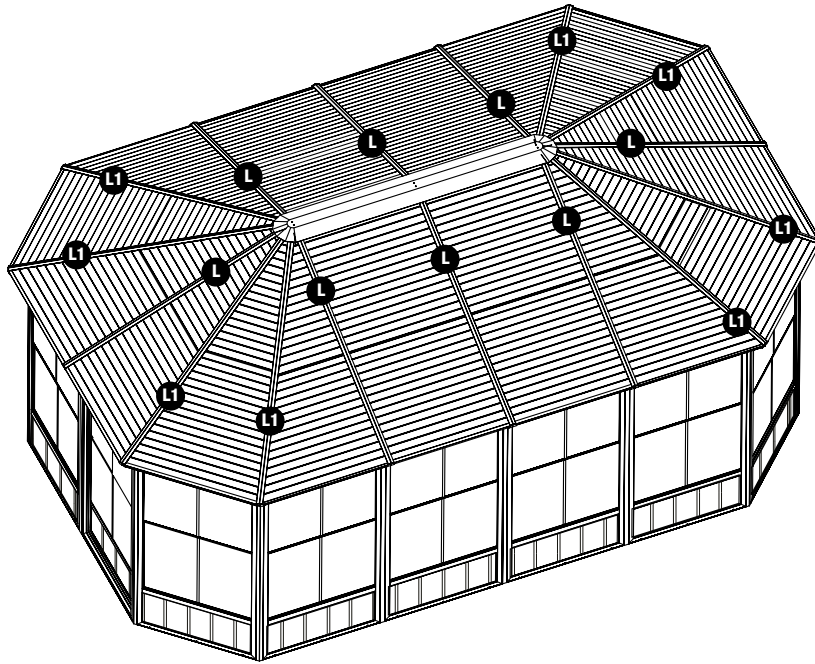

X16

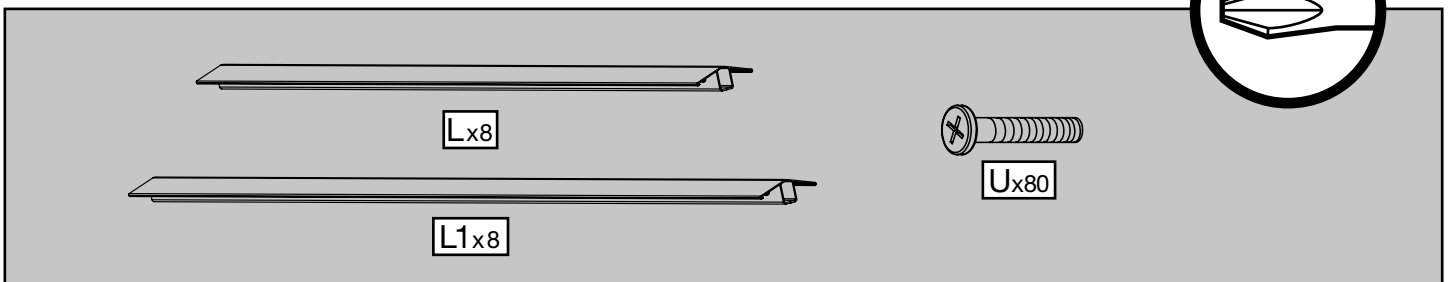
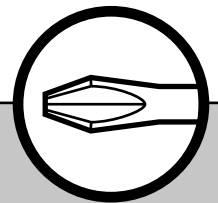
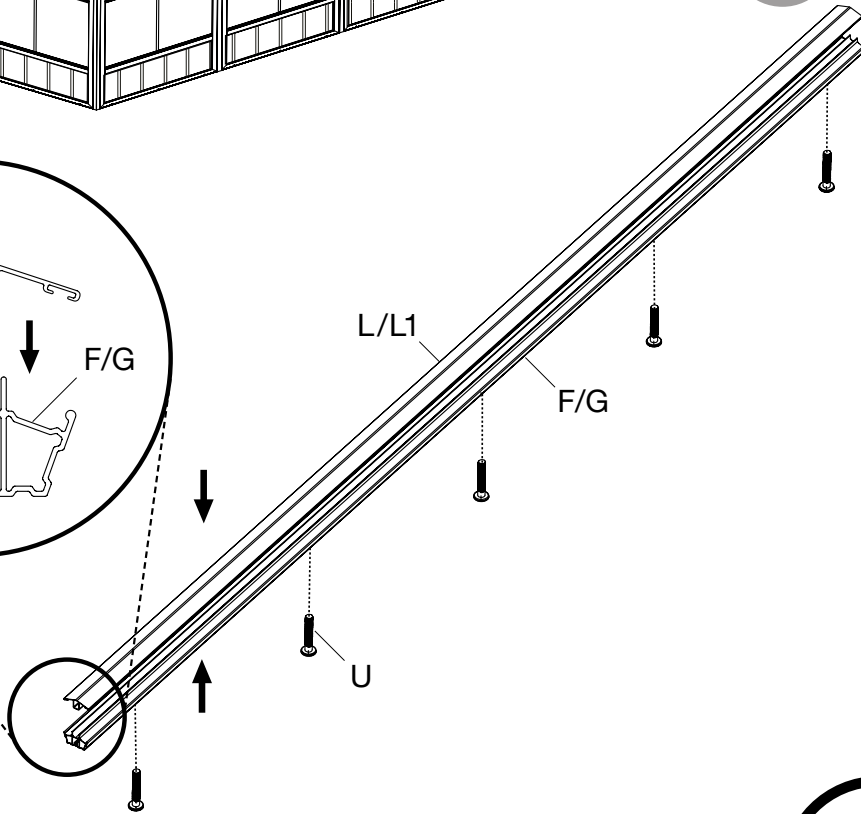
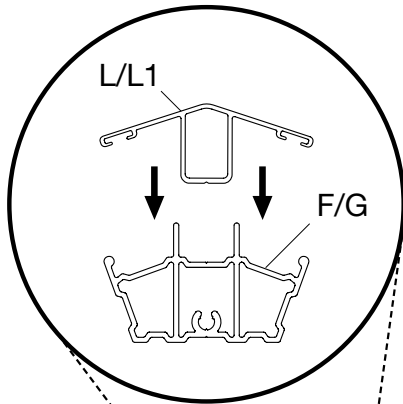

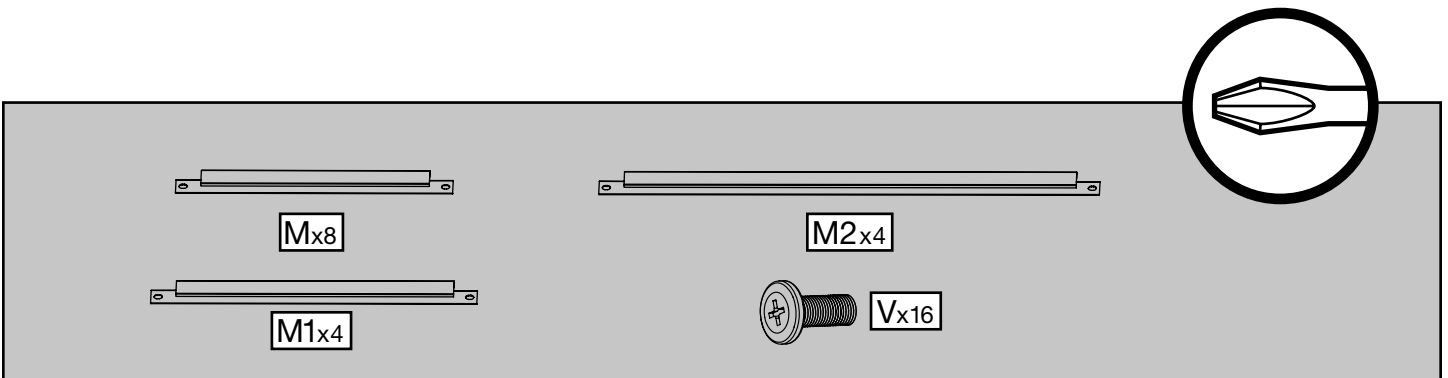
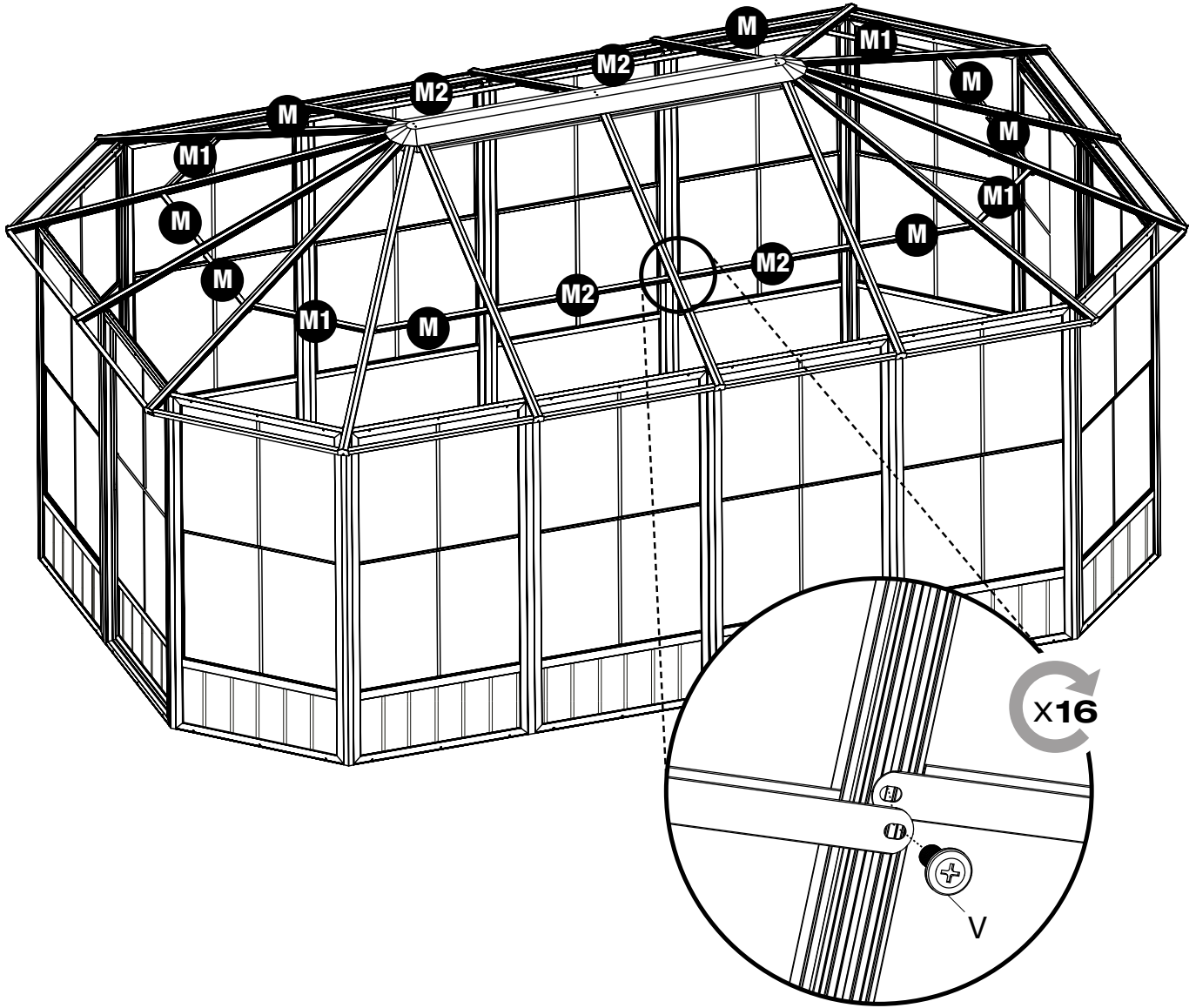

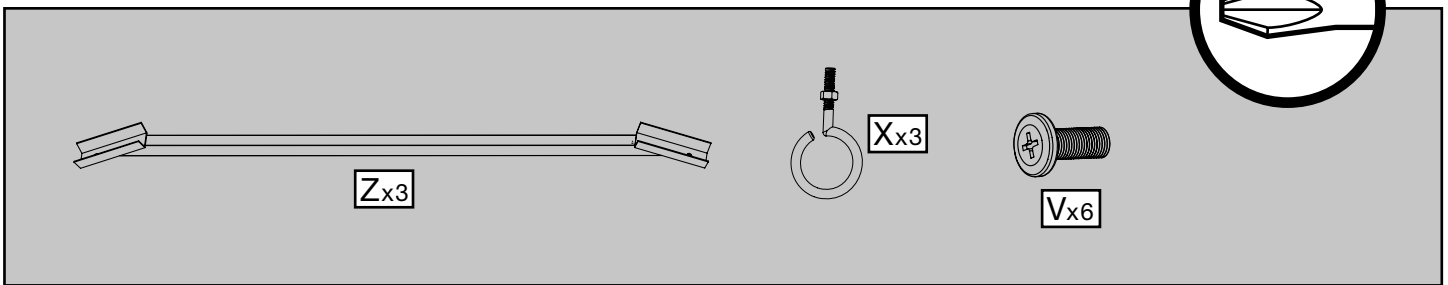
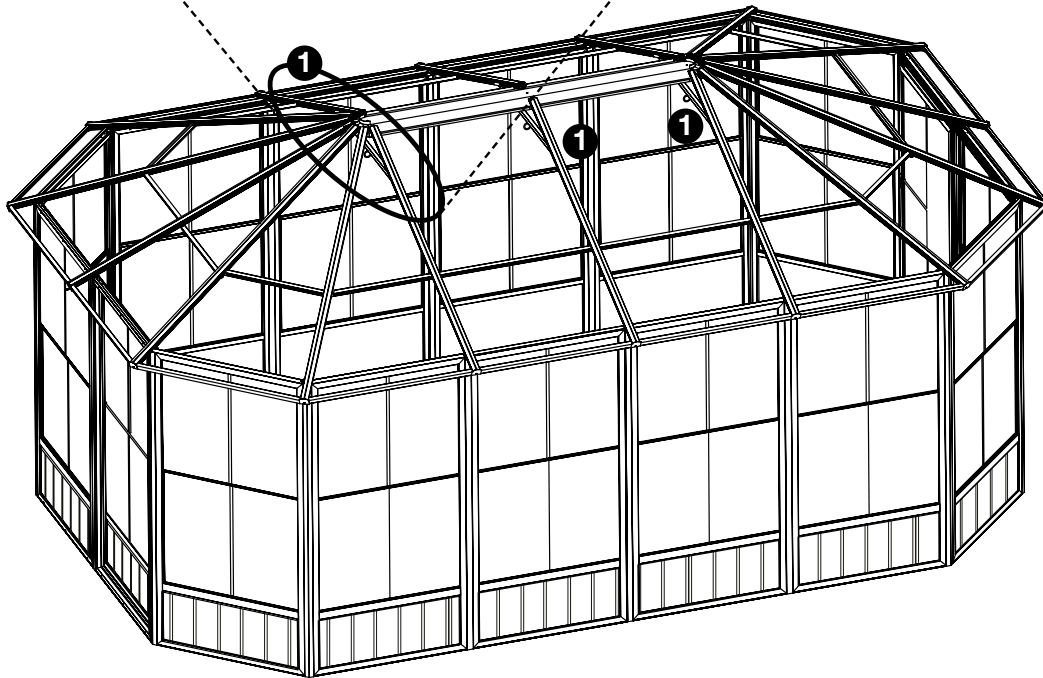
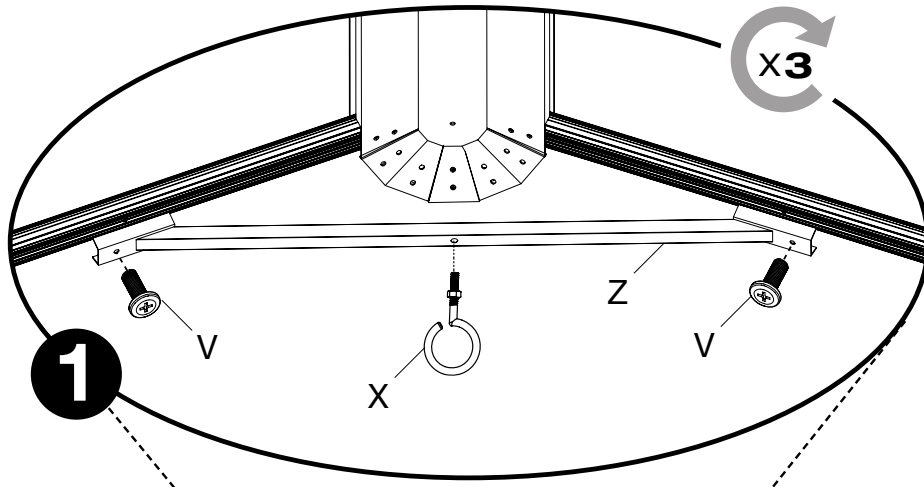

SOJAG ■ I
produits saisonniers • seasonal products