

MS11T5018AC

SAMSUNG

Samsung Countertop Microwave
1.1 cu. ft. Capacity



Signature Features

Intuitive Display

Glass touch control panel combines ease of use with innovative design.

Ceramic Enamel Interior

Scratch-resistant and easy-to-clean interior.

Makes removing grease or oil effortless and protects against scratches from daily use.

Triple Distribution System

Improves the heat distribution to cook food more evenly and thoroughly.

Available Colours



Charcoal (shown)



White



Intuitive Display



Ceramic Enamel Interior

Features

- 1.1 cu. ft. Capacity
- 1000W of Cooking Power
- LED Display
- Dessert/Popcorn
- Auto Defrost
- Auto Cook
- 10 Power Levels
- Cooking Presets
- Eco Mode

Convenience

- Clock (12 hr)
- Child Safety Lock
- Sound On/Off

MS11T5018AC

SAMSUNG

Samsung Countertop Microwave
1.1 cu. ft. Capacity

Dimensions

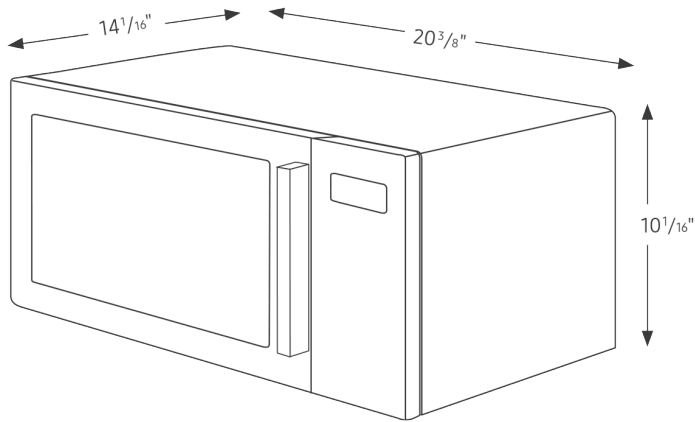

Specifications

- Oven Cavity: 1.1 cu. ft.
- Power Output:
 - Microwave: 900W
- Power Consumption (Microwave): 1500W
- Power Source: 120V/60Hz
- Control Method: Touch
- Display: LED
- Cooking Control: 10 Power Levels
- Microwave Distribution Mechanism: Turntable

Warranty

One (1) Year Parts and Labour
Ten (10) Years on Magnetron Microwave Technology

Product Dimensions & Weight (WxHxD)

Cavity Dimensions: 14¹/₁₆" x 10¹/₁₆" x 14¹/₁₆"
Outside Net Dimensions: 20³/₈" x 11³/₄" x 16¹/₈"
Weight: 34 lbs (15.4 kg)

Shipping Dimensions & Weight (WxHxD)

Dimensions: 22⁷/₁₆" x 14¹/₄" x 18³/₈"
Weight: 41.9 lbs (19 kg)

Colour	Model #	UPC
Charcoal	MS11T5018AC/AC	887276407609
White	MS11T5018AE/AE	887276407623