



**BESTAR**  
Reinvent your space™



<http://bestar.ca>  
<http://bestar.com>

MODEL • MODÈLE • MODELO
<b>115420-1</b>
COLOR • COULEUR • COLOR
WO

RIGHT ASSEMBLY  
INSTRUCTIONS

INSTRUCTIONS  
D'ASSEMBLAGE DROIT

INSTRUCCIONES  
DE ENSAMBLAJE  
DERECHO

LEFT ASSEMBLY  
INSTRUCTIONS

INSTRUCTIONS  
D'ASSEMBLAGE GAUCHE

INSTRUCCIONES  
DE ENSAMBLAJE  
IZQUIERDO



**Video assembly guides**  
Guides d'assemblage en vidéo  
Instrucciones de ensamblaje de vídeo  
[www.bestar.com/video-assembly-guides](http://www.bestar.com/video-assembly-guides)

**SERVICE • SERVICIO**  
1-888 8BESTAR (1-888 823-7827)



Should you need more information concerning the warranty, do not call to the place of purchase. Please call our customer service department for immediate assistance using the toll free number below. Please have your assembly instruction manual on hand when you call.

BESTAR products are warranted to the original purchaser against defects in material or workmanship in the furniture. Defects as mentioned in this warranty refer to any imperfections which may impair the use of the product. Our warranty is expressly limited to the replacement of furniture parts and components for the time specified in the product description and following the date of purchase. BESTAR will replace any part that is defective. This warranty applies under conditions of normal use. Our furniture products are not intended for outdoor use, except those in the Outdoor Collection. The warranty does not cover labor or assembly costs or defects caused by improper assembly or disassembly, after-purchase product modifications, intentional damage, accidents, or exposure to the elements. Bestar reserves the right to request a proof of purchase to document a warranty claim. In no event shall BESTAR be liable for incidental or consequent damages resulting from the misuse of the product. This warranty is not transferable and is valid only in Canada and the United States excluding Alaska, Hawaii and Puerto Rico.

---

Si vous souhaitez de plus amples informations concernant votre garantie, ne vous adressez pas au magasin où vous avez effectué votre achat. Pour obtenir une aide immédiate, veuillez appeler notre service client au numéro sans frais ci-dessus. Veuillez avoir en main le manuel d'instructions lors de votre appel.

La garantie des produits BESTAR est valide pour l'acheteur initial en cas de défaut de matériaux ou de fabrication. Les défauts couverts par cette garantie incluent toutes les imperfections qui peuvent nuire à l'utilisation normale du produit. Notre garantie est expressément limitée au remplacement des composants et des éléments de meubles pour une durée spécifiée sur la fiche produit et suivant la date de l'achat. BESTAR s'engage à remplacer tout élément défectueux. Cette garantie s'inscrit dans le cadre d'une utilisation du produit dans des conditions normales. Nos meubles ne sont pas destinés à être utilisés à l'extérieur, sauf ceux de la collection Outdoor. La garantie ne couvre pas les coûts de main-d'œuvre ou d'assemblage ni les défauts causés par un assemblage ou un démontage non conforme, par des modifications apportées au produit, par des dommages intentionnels, par un accident ou par l'exposition des meubles aux intempéries. Bestar se réserve le droit d'exiger une preuve d'achat afin de documenter la réclamation. La société BESTAR ne pourra être tenue, en aucun cas, responsable de dommages indirects ou consécutifs suite à une mauvaise utilisation du produit. Cette garantie ne peut être transférée et est valide au Canada et aux États-Unis sauf à Hawaï, à Puerto Rico et en Alaska.

---

*Si necesita más información sobre la garantía, no vaya al lugar donde realizó la compra. Llame a nuestro departamento de atención al cliente para recibir ayuda inmediata utilizando nuestro servicio de llamada gratuita. Cuando llame, tenga a mano su manual de instrucciones de montaje.*

*Los productos BESTAR están garantizados por el comprador original contra defectos en el material o en la confección del mueble. Los defectos, tal como se describen en esta garantía incluyen toda imperfección que pueda impedir el uso normal del producto. Nuestra garantía se limita expresamente al reemplazo de las partes y componentes del mueble defectuosos por diez años a partir de la fecha de compra. BESTAR reemplazará cualquier pieza defectuosa. Esta garantía se aplica según las condiciones de uso normal. Nuestros productos no están diseñados para ser utilizados al aire libre. La garantía no cubre defectos causados por ensamblaje o desensamblaje incorrectos, defectos ocurridos luego de la compra por la modificación del mueble, daños intencionales, accidentes, exposición a los agentes naturales ni costos derivados de la fabricación o ensamblaje. Bestar se reserva el derecho de solicitar una factura de compra para poder extender un reclamo de garantía. Bajo ninguna circunstancia BESTAR será responsable de los daños accidentales o consecuentes que pudieran resultar del uso incorrecto del producto. Esta garantía es intransferible y se aplica solamente a Canadá y los Estados Unidos.*



If there are parts missing from your order or if your product was damaged during shipping,  
**PLEASE CONTACT US DIRECTLY.**

S'il vous manque des pièces ou si votre meuble a été endommagé pendant le transport,  
**VEUILLEZ NOUS CONTACTER DIRECTEMENT.**

*En caso de piezas faltantes o si su producto fue dañado durante el envío,  
**POR FAVOR CONTÁCTENOS DIRECTAMENTE.***

**Need help? • Questions? • ¿Cuestión?**

**If you have any questions or concerns,  
please visit our website:**

Si vous avez des questions ou des préoccupations,  
veuillez visiter notre site web à l'adresse :

*Si tiene dudas o inquietudes, visite nuestro sitio web:*



[www.bestar.com/support](http://www.bestar.com/support)

**or call our toll-free number:**

ou appeler sans frais au :  
*o llame sin costo a:*

**1-888 823-7827**



**Make a phone appointment**  
Prenez un rendez-vous téléphonique  
*Agendar una cita telefónica*

[www.bestar.com/online-appointment](http://www.bestar.com/online-appointment)



**Send us an email**  
Envoyez-nous un courriel  
*Envíenos un correo electrónico*

[www.bestar.ca/contact-us](http://www.bestar.ca/contact-us)



**Need help?**  
Besoin d'aide?  
*¿Necesita ayuda?*

[www.bestar.com/faq](http://www.bestar.com/faq)

**Activate your warranty now:**

Activez votre garantie dès maintenant :

*Active su garantía:*[www.bestar.com/activate-my-warranty](http://www.bestar.com/activate-my-warranty)**Information required to make a warranty claim**

Éléments nécessaires pour présenter une réclamation

*Información necesaria para hacer válida la garantía***A copy of your receipt.**

Copie de votre reçu.

*Una copia de su recibo de compra.***Pictures of the damaged parts.**

Photos des pièces endommagées.

*Fotos de las partes dañadas.***You must know the name of the product, the item number and the name of the store where the item was purchased.**

Repérez votre produit sur Bestar.com. Vous devez connaître le nom du produit, le numéro d'article et le nom du magasin où vous l'avez acheté.

*Debe conocer el nombre y el número del producto y, el comercio donde realizó la compra.***Please collect this information BEFORE contacting our customer service.**

Veuillez recueillir tous ces renseignements AVANT de communiquer avec le service client.

*Por favor, tenga toda esta información a la mano ANTES de contactar al departamento de servicio al cliente.*



**Never leave damp clothes, liquids or damp cloths on the furniture.  
If a liquid has spilled on the furniture, clean the liquid up immediately.**

Ne laissez jamais de liquide ni de vêtements ou de linge humides sur le meuble.

Si un liquide est renversé sur le meuble, épongez-le immédiatement.

*Nunca deje líquidos o un trapos húmedos sobre su mueble.*

*Si se derrama un líquido sobre la superficie del mueble, límpielo inmediatamente.*



**Clean the furniture with a damp cloth, then wipe dry.  
To avoid damaging the finish, do not use cleaning products on the furniture.**

Nettoyez votre meuble avec un linge légèrement humide, puis essuyez-le ensuite.

N'utilisez pas de produits de nettoyage, car cela risque d'endommager le fini.

*Nunca utilice limpiadores químicos, ya que estos dañarán el acabado.*

*Use solo un paño húmedo.*



**Do not put devices with plastic or rubber pads directly on your furniture.  
Instead, attach cloth or felt pads to your device.**

Évitez de déposer des appareils munis de patins en caoutchouc ou en plastique directement sur le meuble. Utilisez des protecteurs en tissu ou en feutre sous les appareils.

*Evite apoyar aparatos con bases de plástico o de goma directamente sobre su mueble.*

*Utilize un protector de tela o de fieltro.*



**To avoid dulling the finish, do not place furniture in direct sunlight.**

Afin de préserver la belle apparence de votre meuble,

évitez de l'exposer à la lumière directe du soleil.

*Para prevenir empañamiento, no exponga el mueble directamente a la luz solar solar.*



**At Bestar, we take pride in manufacturing stylish and functional furniture for your home and workspace. We go beyond manufacturing furniture: we offer solutions to optimize and customize your home and workspace. That's why customer satisfaction is our number one priority!**

Chez Bestar, nous sommes fiers de fabriquer des meubles modernes et fonctionnels pour rehausser votre espace de vie ou votre lieu de travail. Plus encore, nous nous engageons à vous offrir des solutions pour optimiser et personnaliser votre résidence et votre espace de travail. Voilà pourquoi votre entière satisfaction nous tient à cœur !

*En Bestar nos enorgullecemos de crear muebles funcionales y con estilo para su hogar y oficina. Vamos más allá de la fabricación de muebles: ofrecemos soluciones para optimizar y personalizar su hogar u oficina. Por eso su satisfacción es nuestra prioridad número uno.*

---

## Satisfaction Survey

Sondage de satisfaction  
*Encuesta de satisfacción*



---

## Stay in touch with us

Restez en contact avec nous  
Manténgase en contacto con nosotros

[www.bestar.com/blog](http://www.bestar.com/blog)



PARTS / PIÈCES / PIEZAS

CODE / CÓDIGO	QTY / QTÉ / CANT.	CODE / CÓDIGO	QTY / QTÉ / CANT.	CODE / CÓDIGO	QTY / QTÉ / CANT.	CODE / CÓDIGO	QTY / QTÉ / CANT.
20	1	40	1	66	1	81	2
21	1	41	1	67	1	CA01A	2
30	1	42	1	70	1	CA05A	2
31	1	43	1	71	1	CA09A-CL09A	2
32	1	44	1	72	1	CA13A	2
33	1	60	1	80	2	CA15A	2

**RIGHT**  
DROIT  
DERECHO

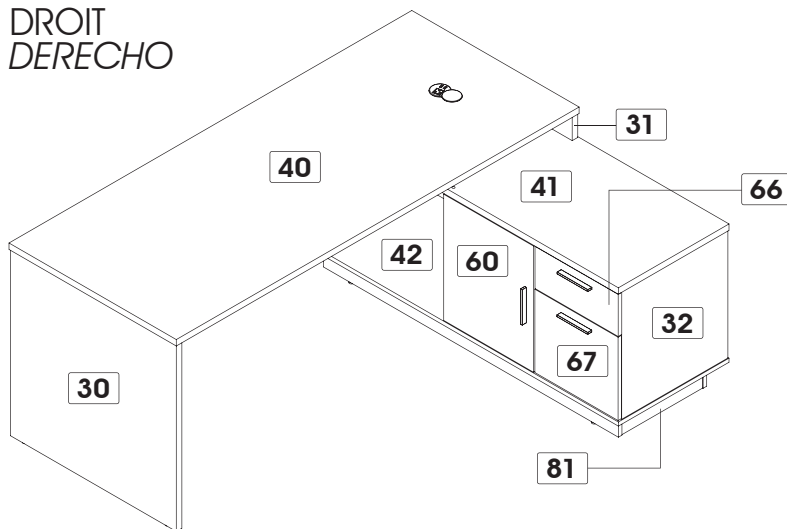

**LEFT**  
GAUCHE  
IZQUIERDO

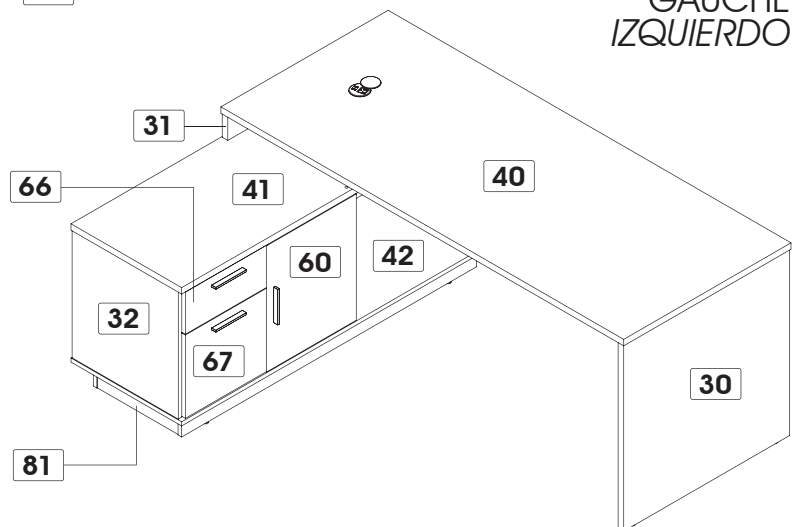











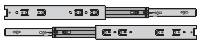

**tools required**  
outils requis  
herramientas necesarias

1/4" (7 mm)

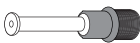

**two people are required to assemble and move this model.**  
deux personnes sont requises pour assembler et déplacer ce modèle.  
se necesitan dos personas para ensamblar y desplazar este mueble.

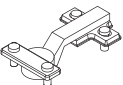
**the use of electric tools must be made with vigilance.**  
l'utilisation d'outils électriques doit être faite avec vigilance.  
las herramientas eléctricas deben utilizarse con sumo cuidado.

**HARDWARE / QUINCAILLERIES / QUINCALLA**

CODE / CÓDIGO	QTY / QTÉ / CANT.	CODE / CÓDIGO	QTY / QTÉ / CANT.	CODE / CÓDIGO	QTY / QTÉ / CANT.	CODE / CÓDIGO	QTY / QTÉ / CANT.
AC-1090	 1	CL-745	 1	EC-744	 4	PF-106	 1
CA-77	 3/8 in/po (10 mm) -	CO-249	 2	H-03	 45	PO-572	 3
CA-99	 5/8 in/po (15 mm) -	EX-743	 1 11 7/8 in/po (303 mm)	H-36	 45	TI-118	 8
CH-838	 2		 1 16 3/16 in/po (411 mm)	PA-844	 1 in/po (25 mm) 7		

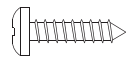
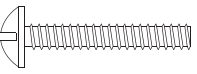
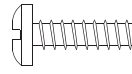
**REAL SIZE / GRANDEUR RÉELLE / TAMAÑO REAL**

CODE / CÓDIGO	QTY / QTÉ / CANT.	CODE / CÓDIGO	QTY / QTÉ / CANT.
VE-244	 3/8 in/po (10 mm) 12	VR-207	 1/2 in/po (13 mm) 12
VF-232	 7/8 in/po (22 mm) 6	VR-212	 1 in/po (25 mm) 16
VM-601	 3/4 in/po (20 mm) 4		

**IMPORTANT NOTICE / NOTE IMPORTANTE / NOTA IMPORTANTE**

**Group together all the hardware required for each step as the construction of your piece of furniture is progressing.**

Regroupez toutes les quincailleries requises pour chaque étape de façon à vous assurer de tout installer au bon moment.  
 Reúna todas las quincallas necesarias para cada una de las etapas de montaje, para asegurar una correcta instalación en el momento adecuado.

**IMPORTANT NOTICE / NOTE IMPORTANTE / NOTA IMPORTANTE**

**H-03**

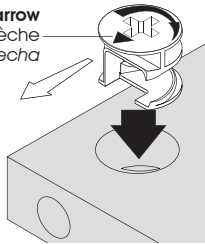

Insert the cam with the arrow pointing towards the hole in the edge.  
 Insérez la rondelle en pointant la flèche vers le trou de la bordure.  
 Inserte la arandela con la flecha apuntando hacia el orificio cercano al borde.

**Main hardware system / Système de quincaillerie principal / Sistema principal de quincalla**

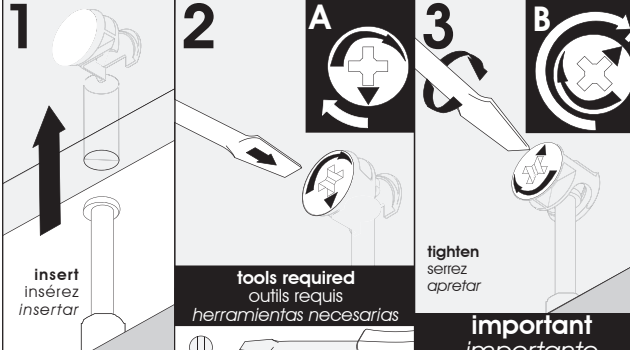

**1** insert / insérez / insertar

**2** tools required / outils requis / herramientas necesarias

**3** tighten / serrez / apretar

**important / importante**

**How to remove a misplaced assembly bolt (H-36).**  
 Comment retirer un boulon (H-36) mal situé.  
 Cómo retirar un perno (H-36) mal ubicado.

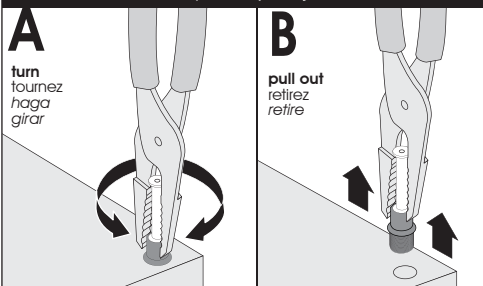

**A** turn / tounez / haga girar

**B** pull out / retirez / retire



**Assembling sequence**

Séquence d'assemblage

Secuencia de ensamblaje

Parts / Pièces / Piezas:

70 30 40 31

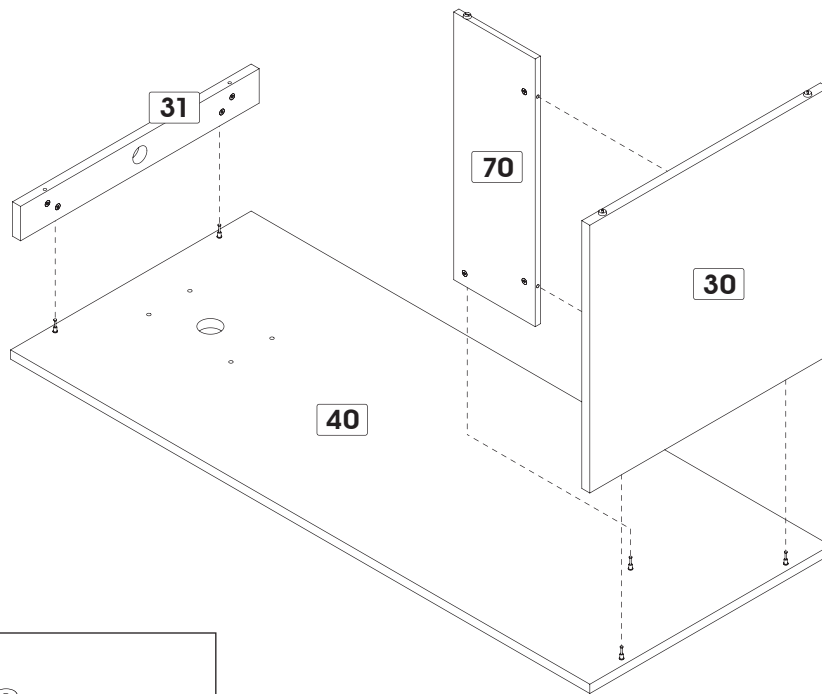
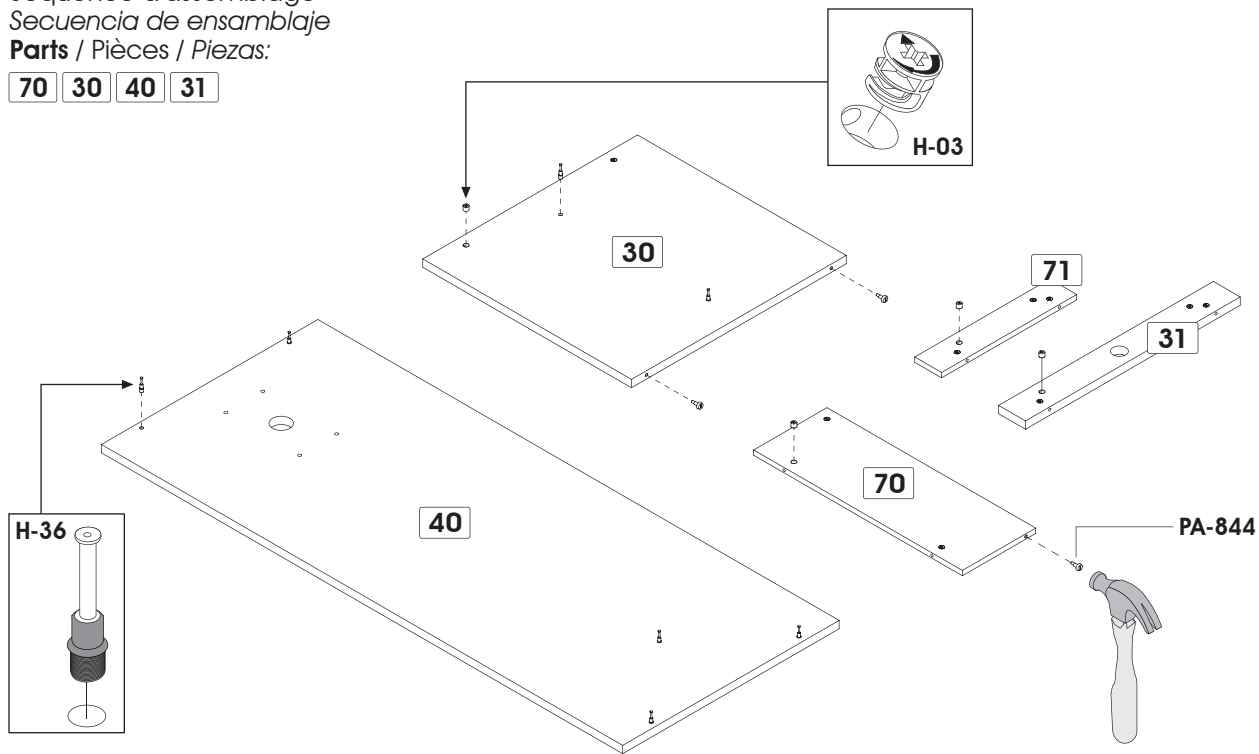

Code / Código	H-03	H-36	PA-844
Qty / Qté / Cant.	x 13	x 7	x 3

1 in/pc (25 mm)

**Assembling sequence**



Séquence d'assemblage

Secuencia de ensamblaje

Parts / Pièces / Piezas:

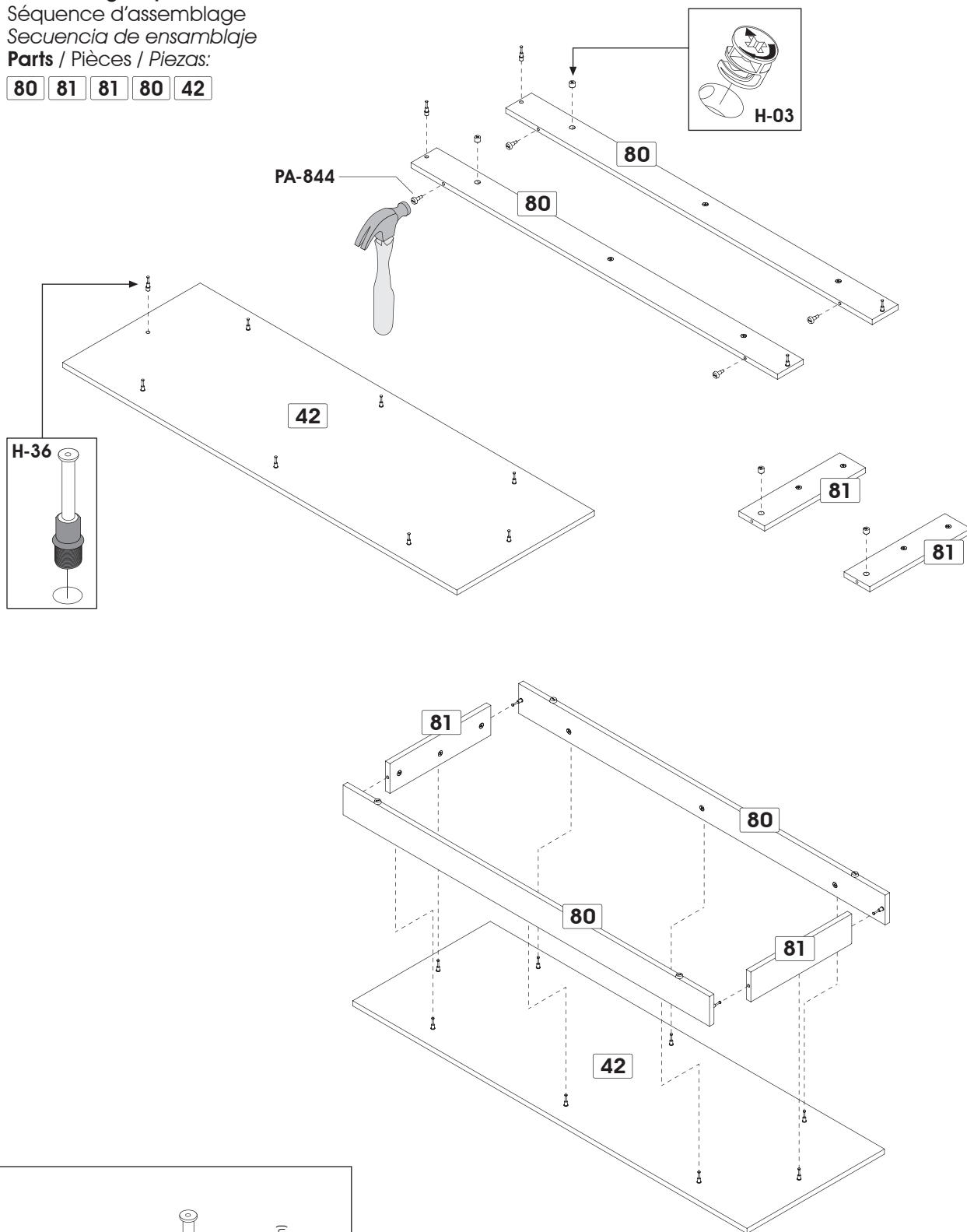
80 81 81 80 42

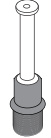

			
Code / Código	H-03	H-36	PA-844
Qty / Qté / Cant.	x 12	x 12	x 4

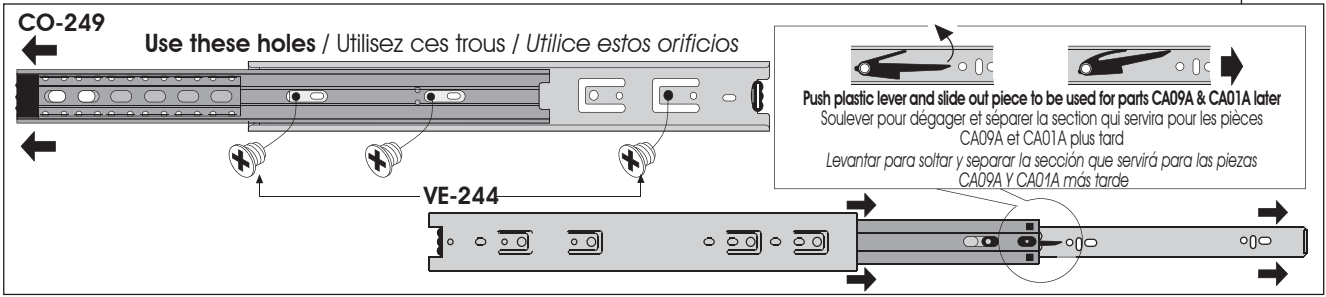
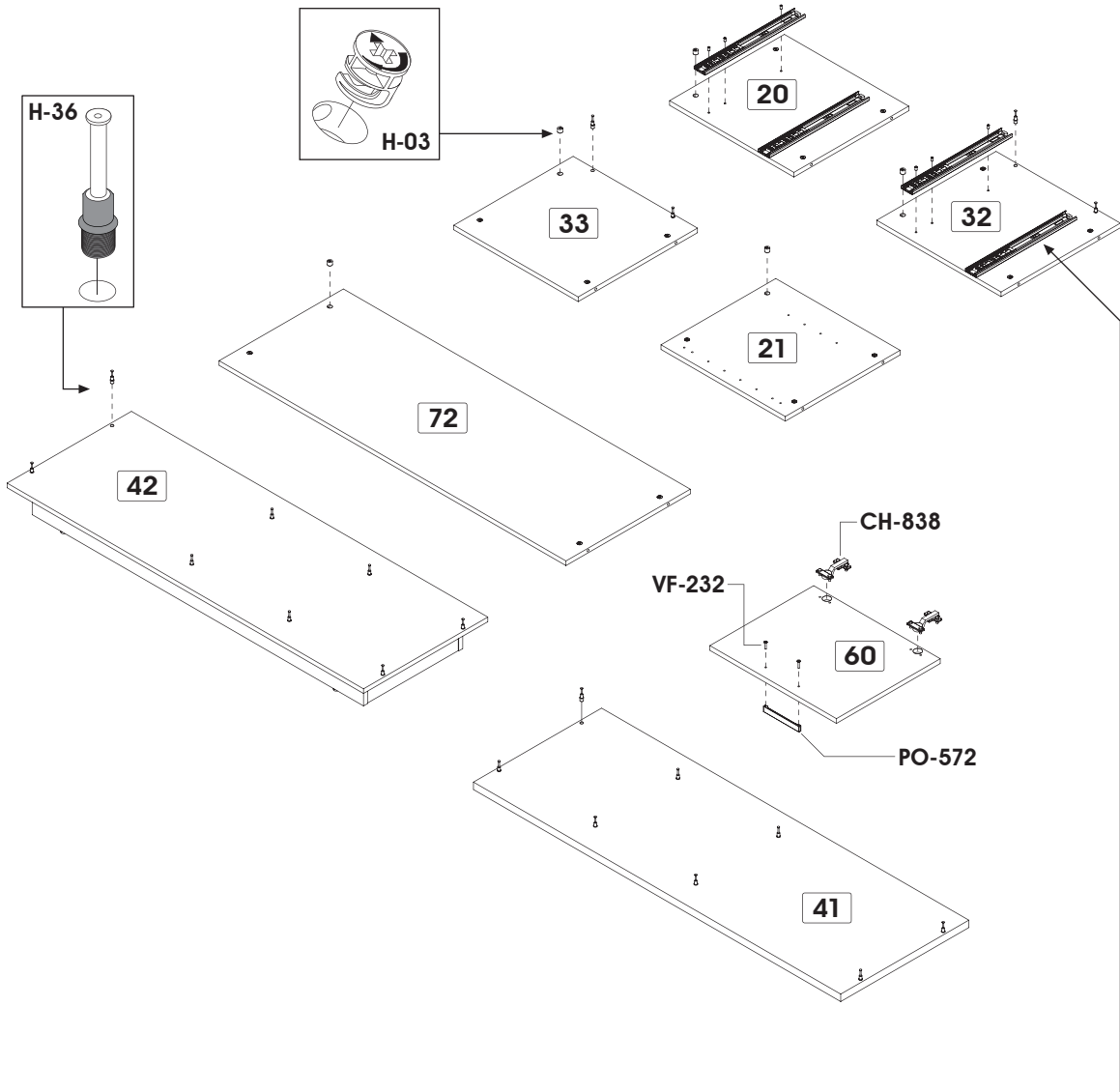

<b>3</b>							
<b>Code / Código</b>	CO-249	CH-838	H-03	H-36	PO-572	VE-244	VF-232
<b>Qty / Qté / Cant.</b>	x 2	x 2	x 20	x 20	x 1	x 12	x 2

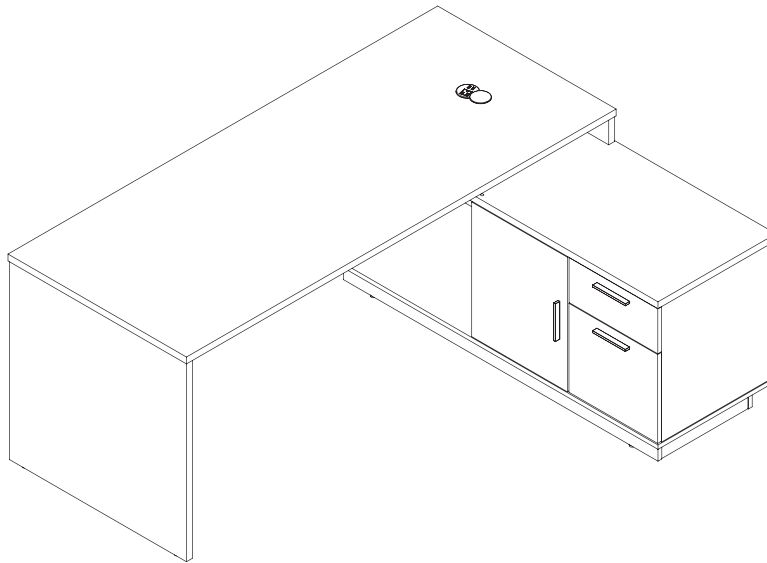

**RIGHT**  
DROIT  
DERECHO

To assemble this model, see pages 9 to 13.  
Pour faire ce montage, consulter les pages 9 à 13.  
Para este modelo, consultar las páginas 9 a 13.

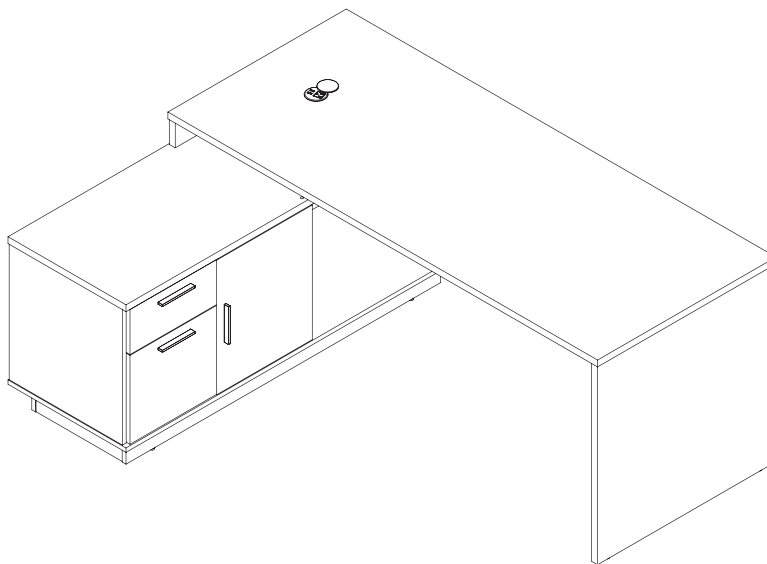

**LEFT**  
GAUCHE  
IZQUIERDO

To assemble this model, see pages 9, 10 and 14 to 16.  
Pour faire ce montage, consulter les pages 9, 10 et 14 à 16.  
Para este modelo, consultar las páginas 9, 10 y 14 a 16.

**Assembling sequence**

Séquence d'assemblage

Secuencia de ensamblaje

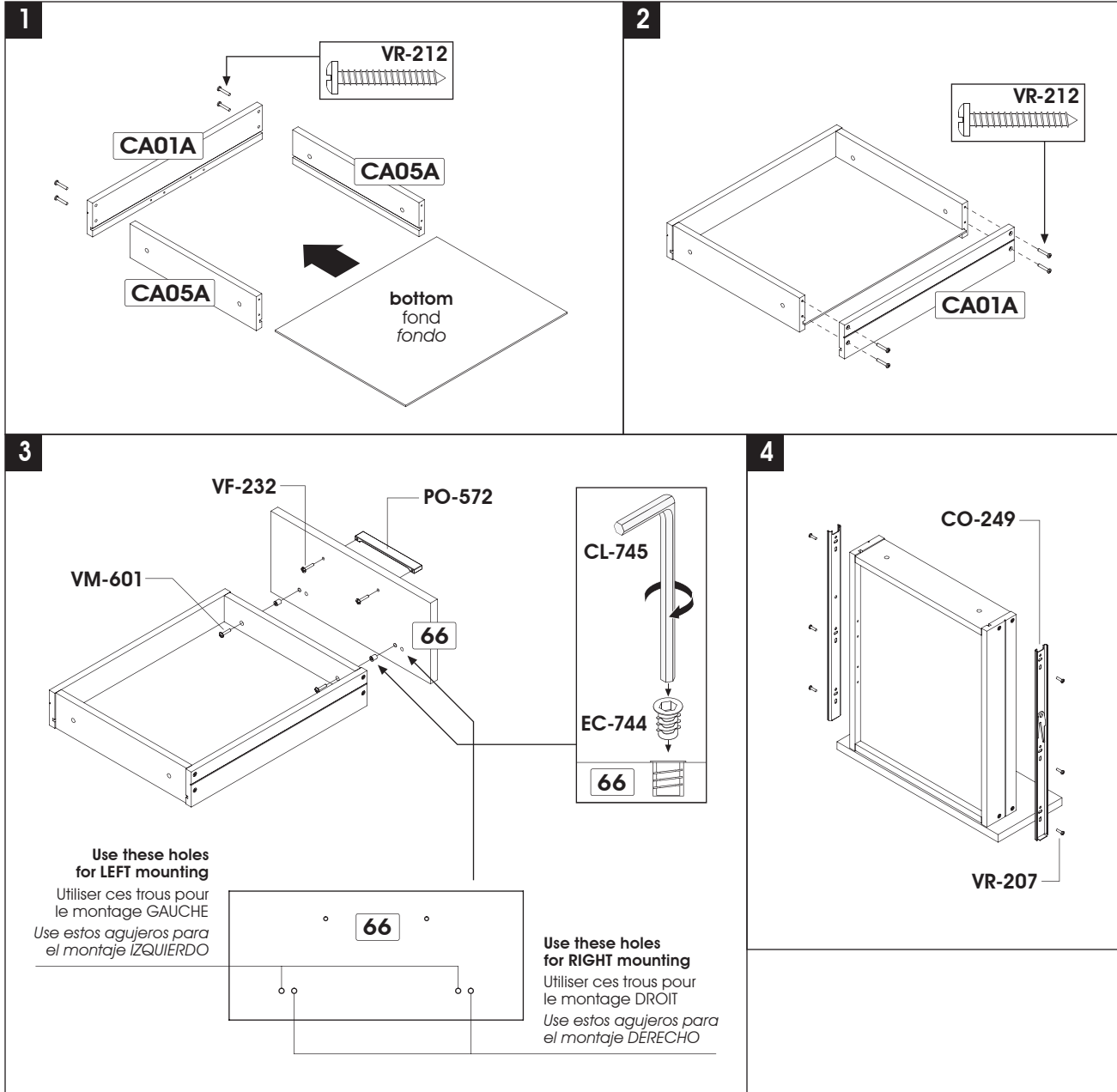

Code / Código	CL-745	CO-249	EC-744	PO-572	VM-601	VR-207	VR-212	VF-232
Qty / Qté / Cant.	x 1	x 1	x 2	x 1	x 2	x 6	x 8	x 2

screws / vis / tornillos

3/4 in(po) (20 mm)

1/2 in(po) (13 mm)

1 in(po) (25 mm)

7/8 in(po) (22 mm)

**Assembling sequence**

Séquence d'assemblage

Secuencia de ensamblaje

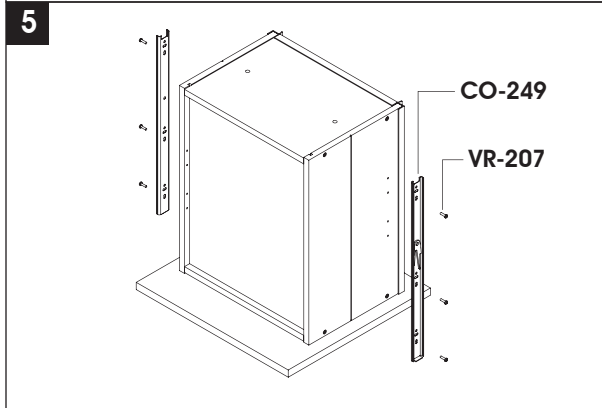
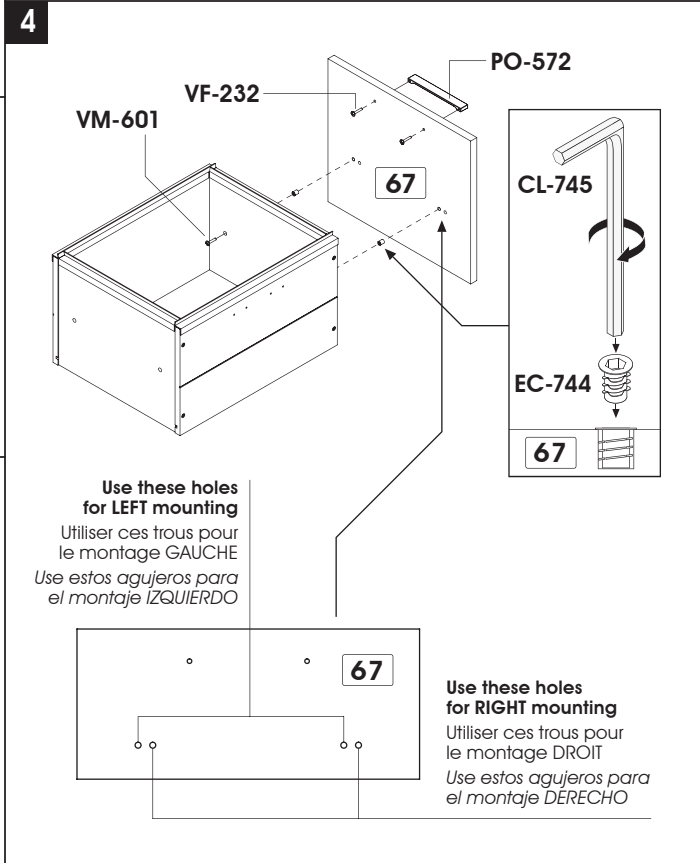
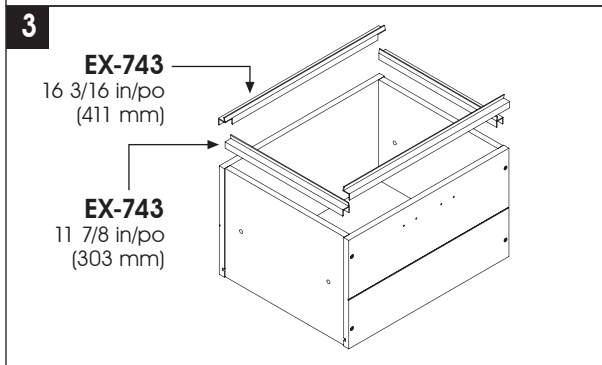
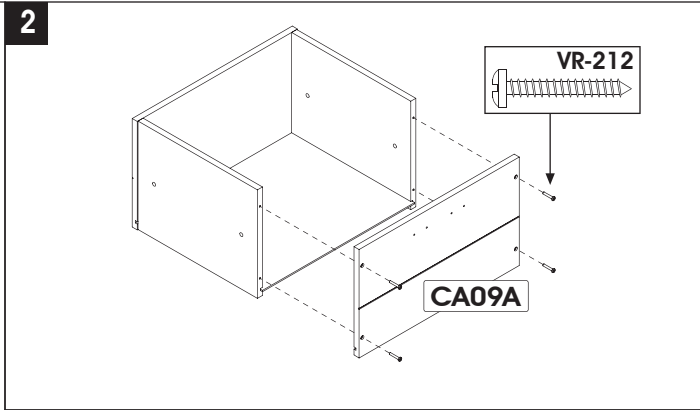
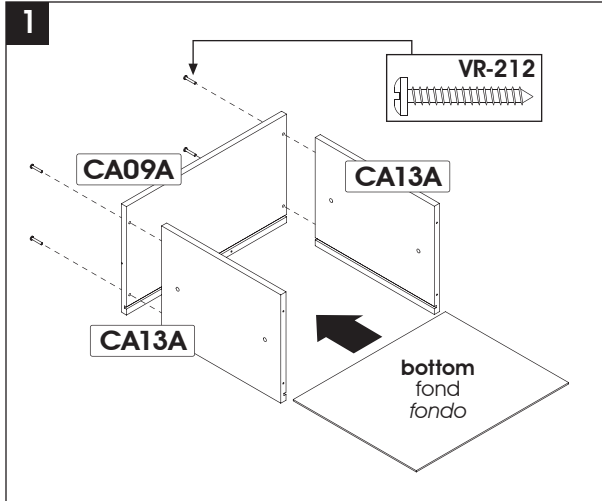

<b>Code / Código</b>	CL-745	CO-249	EC-744	EX-743	PO-572	VM-601	VR-207	VR-212	VF-232
<b>Qty / Qté / Cant.</b>	x 1	x 1	x 2	x 1	x 1	x 2	x 6	x 8	x 2

**RIGHT / DROIT / DERECHO****Assembling sequence**

Séquence d'assemblage

Secuencia de ensamblaje

Parts / Pièces / Piezas:

72 21 20 33 32 42

41

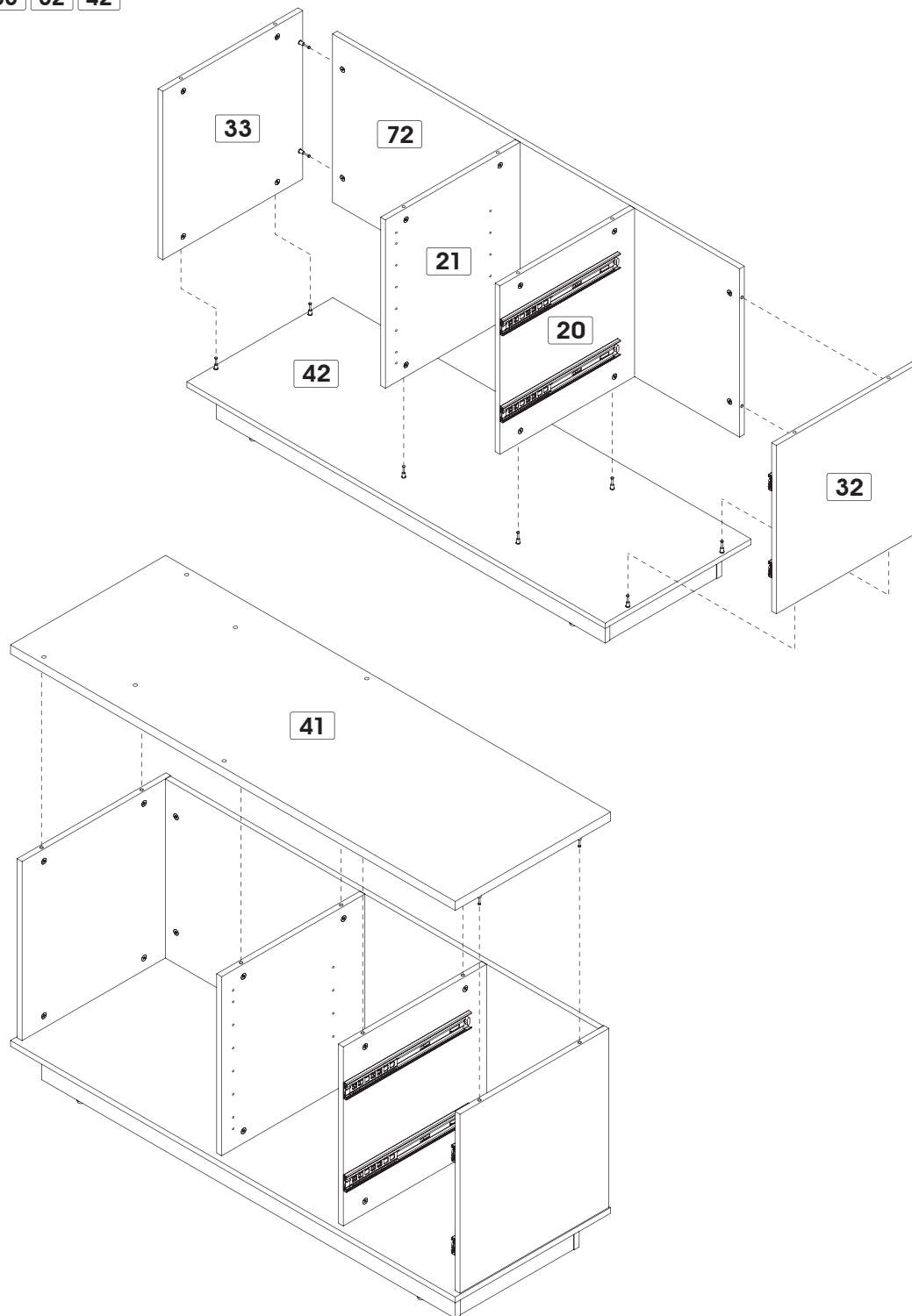

**RIGHT / DROIT / DERECHO****Assembling sequence**

Séquence d'assemblage

Secuencia de ensamblaje

**Parts / Pièces / Piezas:**

71

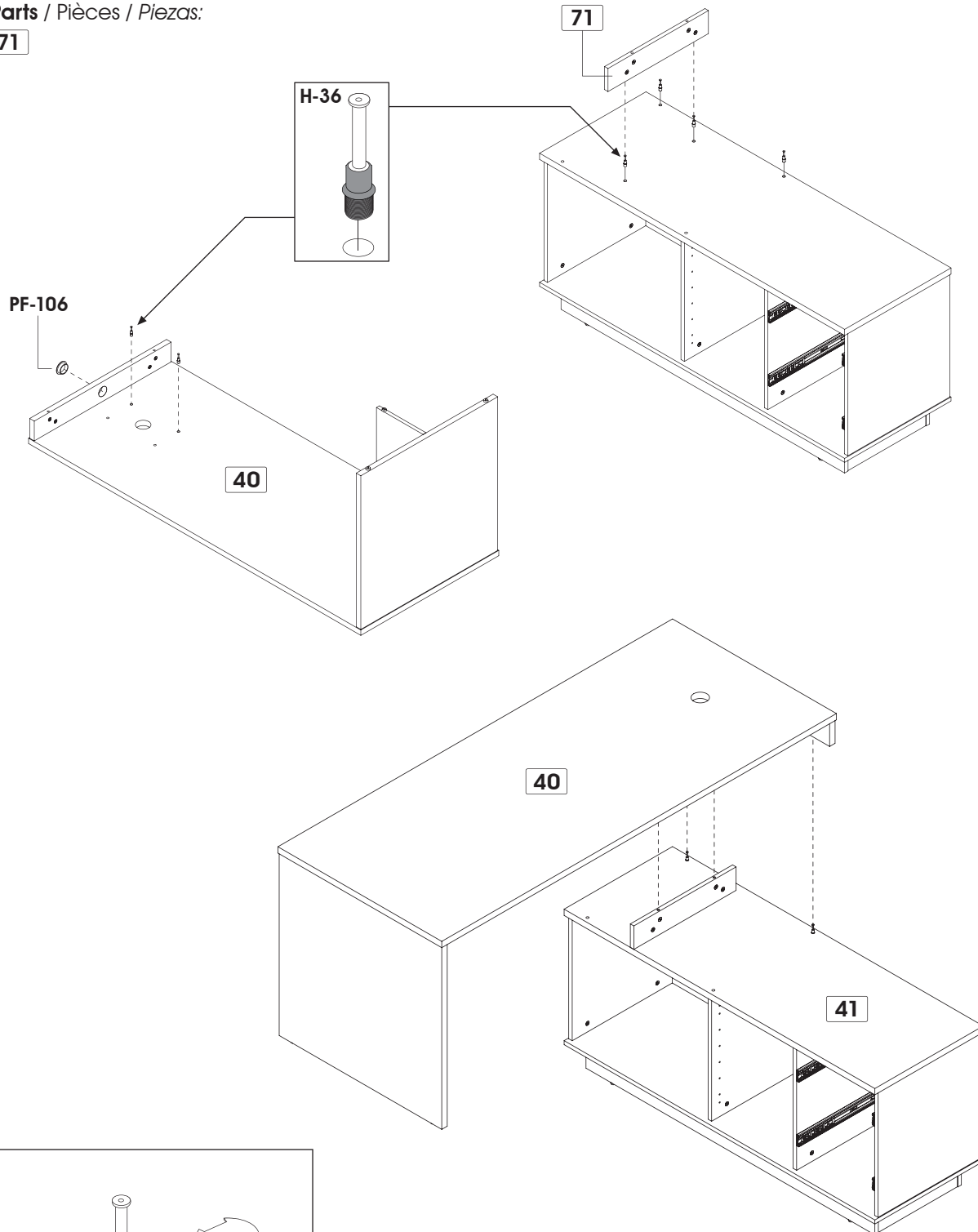

8

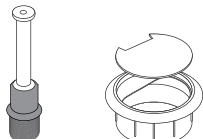

Code / Código

H-36

PF-106

Qty / Qté / Cant.

x 6

x 1

115420

SERVICE/SERVICIO: 1-888 8BESTAR (1-888 823-7827)



**RIGHT / DROIT / DERECHO****Assembling sequence**

Séquence d'assemblage

Secuencia de ensamblaje

Parts / Pièces / Piezas:

60 43 44

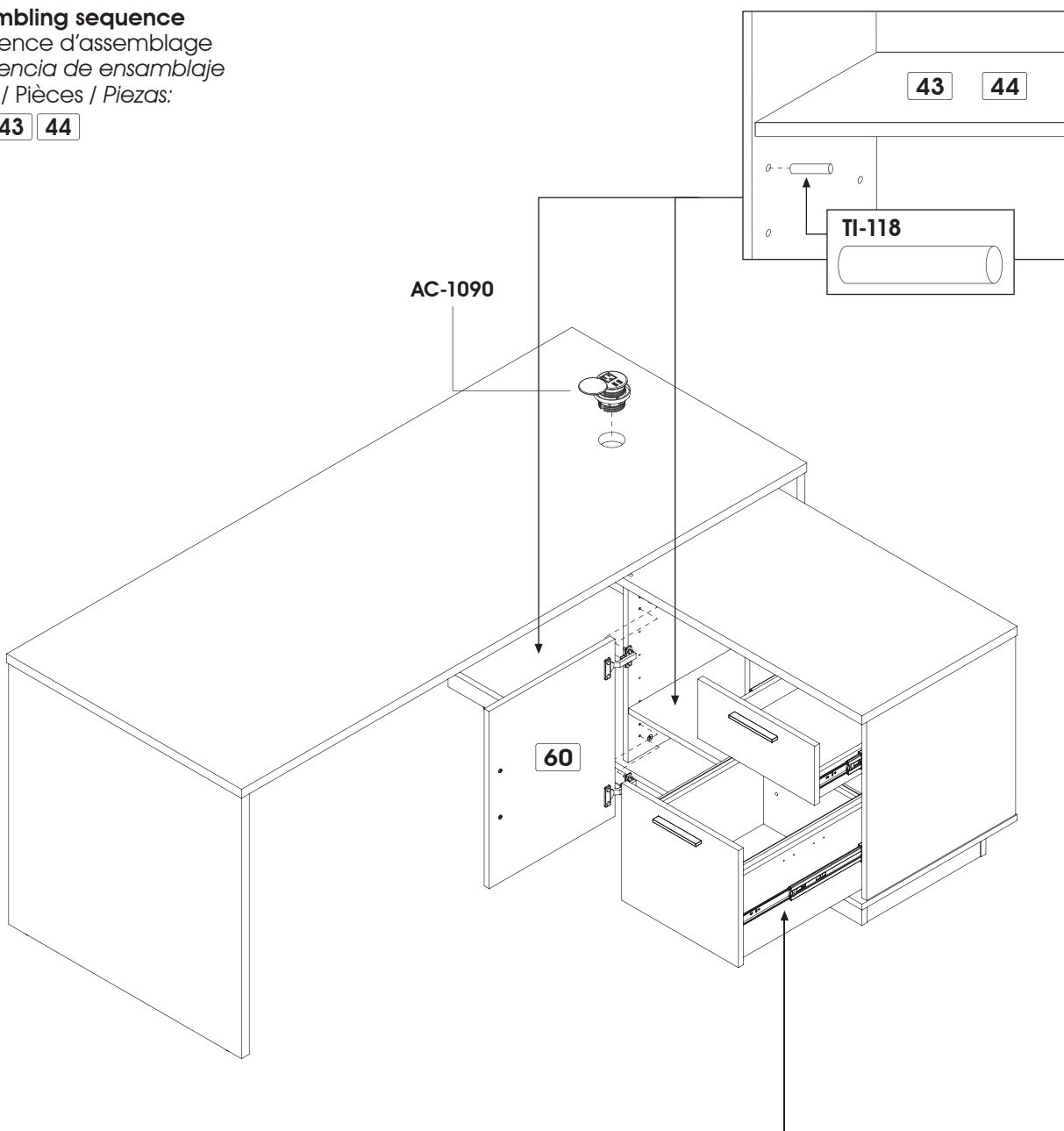
**IMPORTANT / IMPORTANTE**

**Ball bearings must be on front part of slider when installing drawers.**

Les roulements à billes doivent être sur la partie avant du coulisseau lors de l'installation des tiroirs.

Los cojinetes de bolas deben ubicarse sobre la parte delantera de guía en el momento de instalar los cajones.

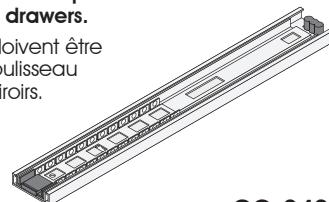

CO-249

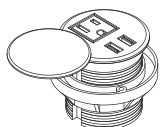

Code / Código

AC-1090

TI-118

Qty / Qté / Cant.

x 1

x 8

115420

SERVICE/SERVICIO: 1-888 8BESTAR (1-888 823-7827)

**LEFT / GAUCHE / IZQUIERDO****Assembling sequence**

Séquence d'assemblage

Secuencia de ensamblaje

Parts / Pièces / Piezas:

72 21 20 33 32 42

41

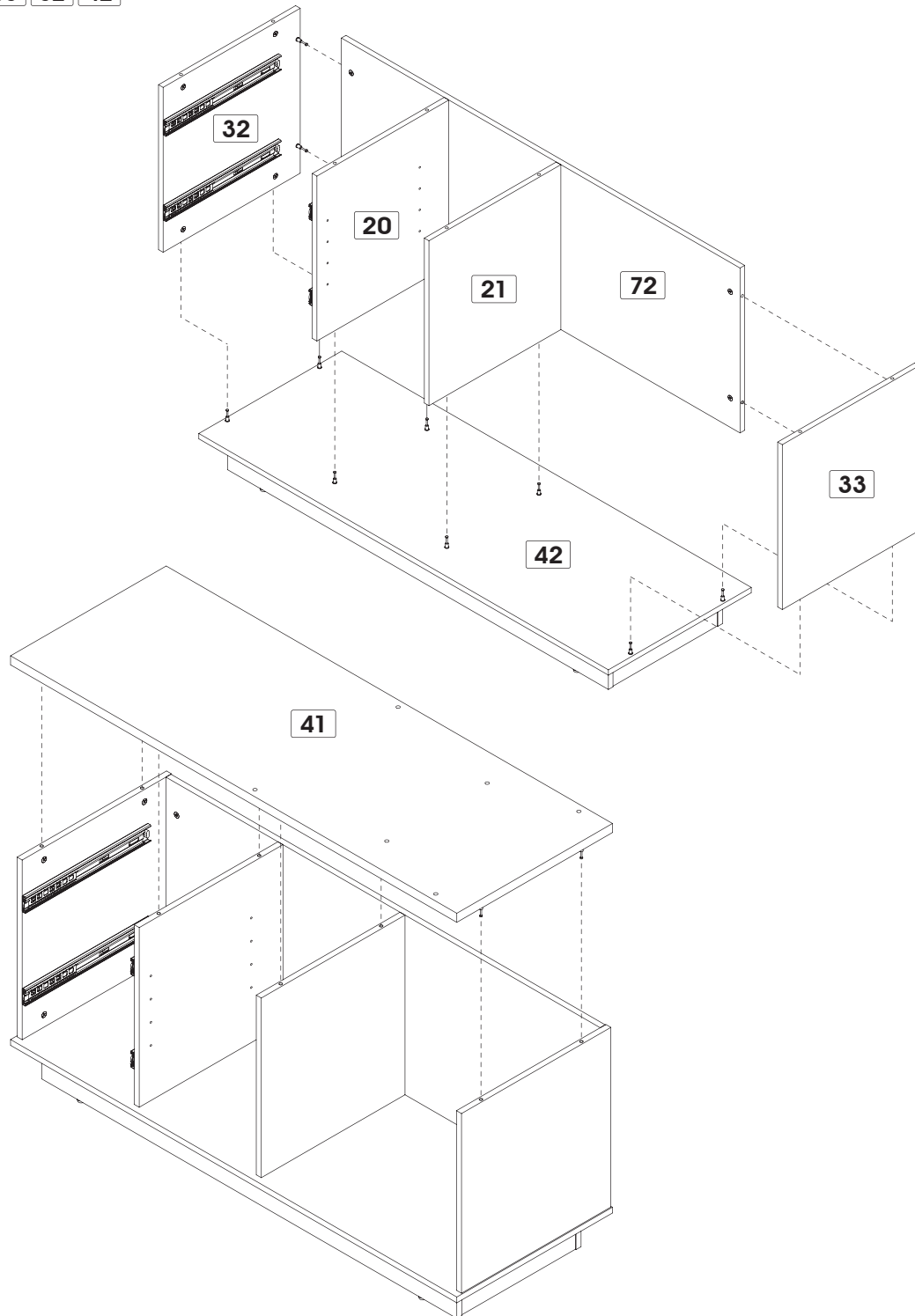

**LEFT / GAUCHE / IZQUIERDO****Assembling sequence**

Séquence d'assemblage

Secuencia de ensamblaje

**Parts / Pièces / Piezas:**

71

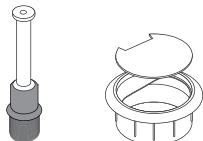
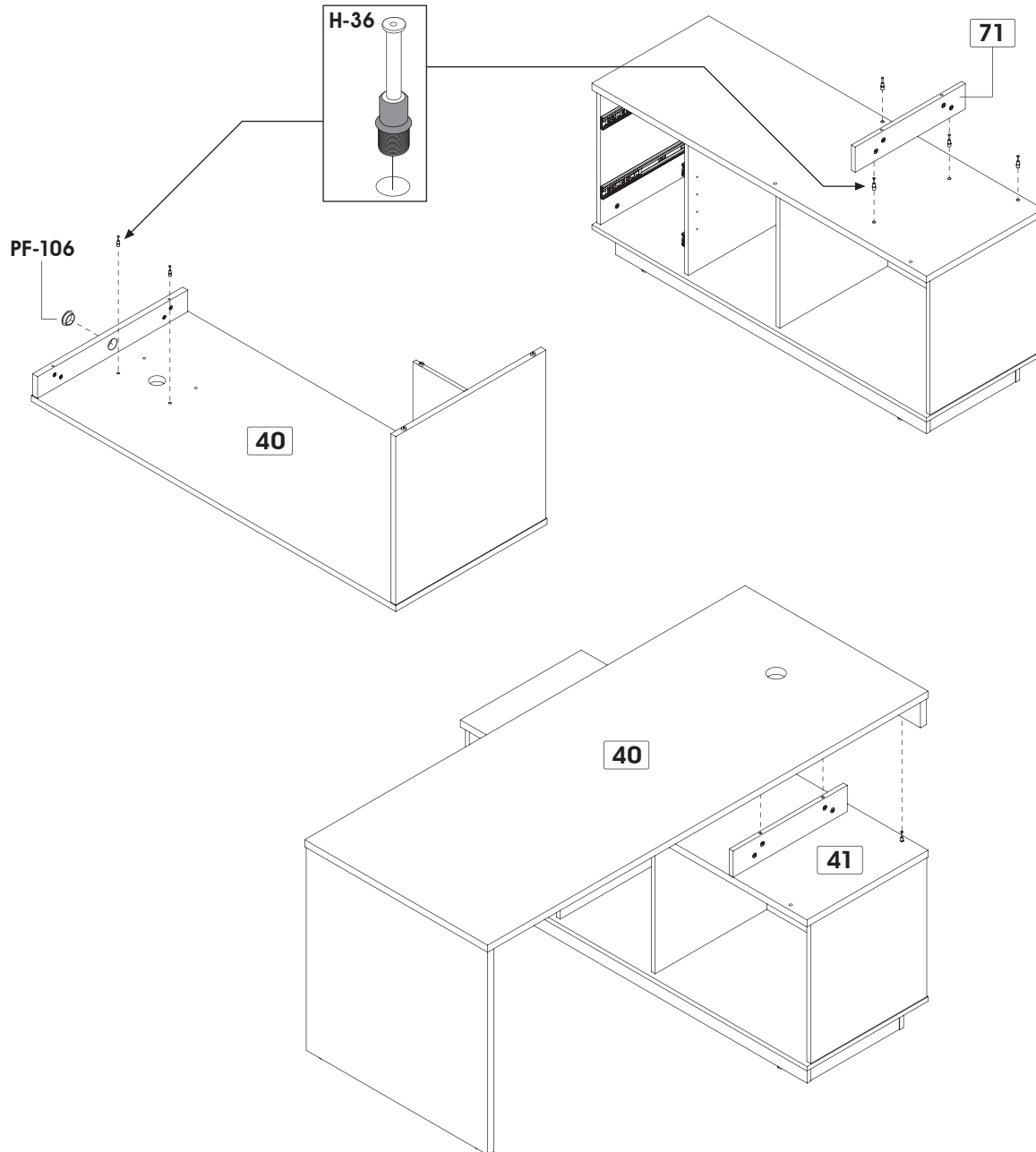

Code / Código

H-36

PF-106

Qty / Qté / Cant.

x 6

x 1

**LEFT / GAUCHE / IZQUIERDO****Assembling sequence**

Séquence d'assemblage

Secuencia de ensamblaje

Parts / Pièces / Piezas:

60 43 44

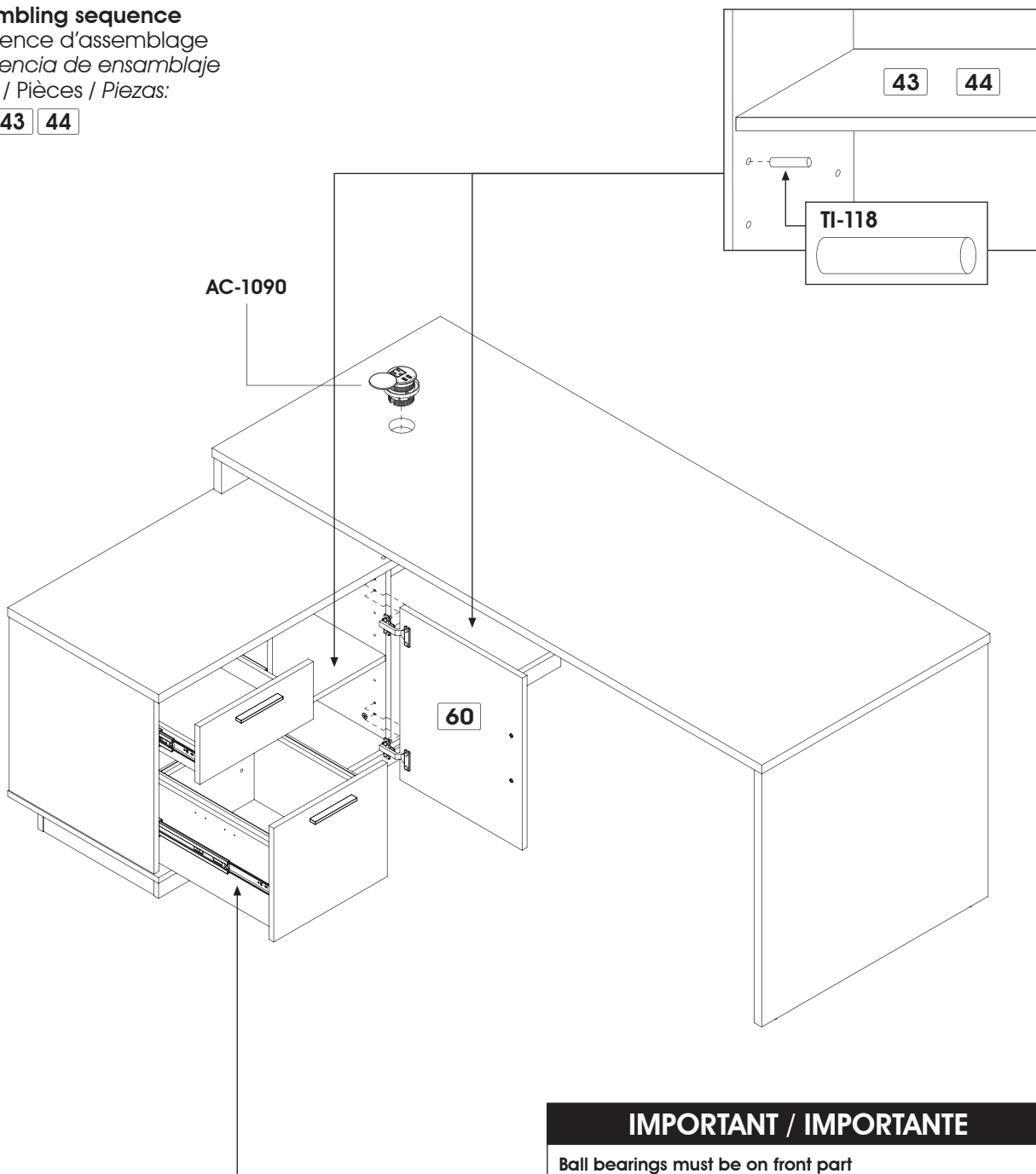
**IMPORTANT / IMPORTANTE**

**Ball bearings must be on front part of slider when installing drawers.**

Les roulements à billes doivent être sur la partie avant du coulisseau lors de l'installation des tiroirs.

Los cojinetes de bolas deben ubicarse sobre la parte delantera de guía en el momento de instalar los cajones.

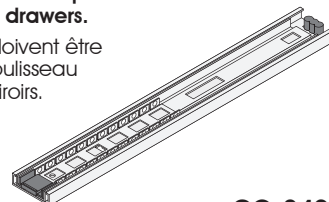

CO-249

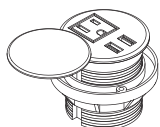

Code / Código

AC-1090

TI-118

Qty / Qté / Cant.

x 1

x 8

115420

SERVICE/SERVICIO: 1-888 8BESTAR (1-888 823-7827)



**BESTAR**  
Reinvent your space™

<http://bestar.ca>  
<http://bestar.com>

MODEL + MODÈLE + MODELO  
**115420-1**  
COLOR + COULEUR + COLOR  
NO

RIGHT ASSEMBLY INSTRUCTIONS  
INSTRUCTIONS D'ASSEMBLAGE DROIT  
INSTRUCCIONES DE ENSAMBLAJE DERECHO

LEFT ASSEMBLY INSTRUCTIONS  
INSTRUCTIONS D'ASSEMBLAGE GAUCHE  
INSTRUCCIONES DE ENSAMBLAJE IZQUIERDO

Video assembly guides  
Guides d'assemblage en vidéo  
Instrucciones de ensamblaje de vídeo  
[www.bestar.com/video-assembly-guides](http://www.bestar.com/video-assembly-guides)

SERVICE + SERVICIO  
1-888 8BESTAR (1-888 823-7827)



**BESTAR**

To better serve you!  
Pour mieux vous servir!

Model / Modèle: \_\_\_\_\_

Production Number  
Numéro de production: \_\_\_\_\_

Customer Service **1-888-823-7827**  
Service à la clientèle

For future reference and to allow us to serve you better, please complete the self-adhesive sticker and apply it in an accessible space such as under shelf.

Pour que nous puissions mieux vous servir en cas de besoin, veuillez compléter l'autocollant et l'apposer dans un endroit facilement accessible tel que le dessous d'une tablette.

Para futuras referencias y un mejor servicio, por favor pegue la etiqueta adhesiva en un espacio accesible. Por ejemplo, la parte interior del estante

When you have completed the assembly of your new furniture, install plastic caps

