

RF18A5101SR

SAMSUNG

French Door Refrigerator with Recessed Handle and Flat Door Design 17.5 cu. ft.



Signature Features

Twin Cooling Plus™

Optimizes the temperature and humidity in the fridge and freezer with an independent cooling system.

Digital Inverter Compressor

Automatically adjusts its speed in response to cooling demand across 7 levels. As a result, it's quieter and uses up to 50% less power.

Fingerprint Resistant Finish

Avoid smudges with fingerprint resistant stainless steel.

Built-in Wi-Fi

With the embedded Wi-Fi, you can monitor and control your refrigerator anytime, anywhere using a smartphone App¹. You can easily control its Rapid Cooling modes, check the temperature, and get alerts if the door is left open.

Modern design with Recessed Handle

A premium modern look that is both sleek and neat, won't look out of place with your existing appliances and cabinetry, and has beautiful flat doors with recessed handles that don't protrude.

Available Colours

Fingerprint Resistant
Stainless Steel (shown)

Fingerprint Resistant
Black Stainless Steel



French Door Design



Twin Cooling Plus™

Features

- 33" Wide
- Large Storage Capacity – 17.5 cu. ft.
- Ice Maker in Freezer
- High-Efficiency LED Lighting
- Tempered Glass Spill-Proof Shelves
- Auto Pull-Out Upper Freezer Drawer

Convenience

- CoolTight Door
- Door Alarm
- Removable Ice Caddy

Rating



- ENERGY STAR® - Rated
- Energy Consumption (annual) = 540 kWh/yr

¹Available on Android and iOS devices. A Wi-Fi connection and a Samsung account are required.

French Door Refrigerator with Recessed Handle and Flat Door Design 17.5 cu. ft.

Installation Specifications

1. Measure the height, width and depth of the opening, making sure to include baseboards, molding tile, countertop overhang, etc. Check to be sure there is enough room to open the door (consider walls, islands or other obstacles when measuring).
2. Refer to illustration below to determine dimensions.
3. Allow 3.75" of clearance on hinge side of refrigerator when installing next to a wall where handle may make contact.
4. Allow 2" minimum clearance at rear for proper air circulation and water/electrical connections. Allow a 3/8" minimum clearance at sides and top for ease of installation.
5. Ensure each door and entryway in the home is wide enough for the refrigerator to be moved through easily.

For optimal usage and to be able to open refrigerator doors completely, do not install next to a wall.

Please note: The following dimension and cutout information is for planning purposes only. For complete installation details, consult manual packed with product, or download manual online at samsung.com.

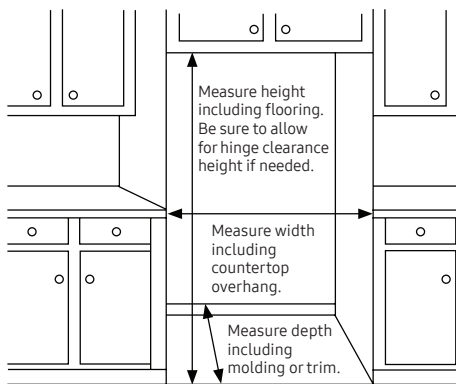

Dimensions

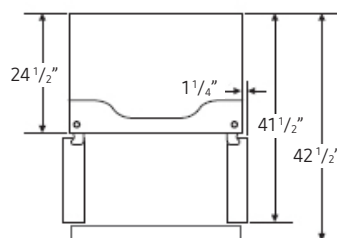
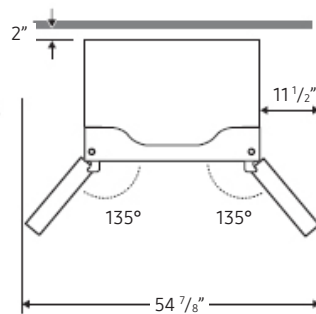
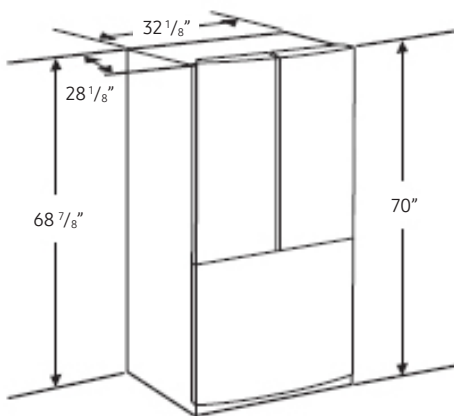

Total Capacity: 17.5 cu. ft.

Refrigerator: 11.7 cu. ft.

- Twin Cooling Plus
- 2 Crispers
- 3 Tempered Glass Spill Proof Shelves
- 3 Door Bins
- High-Efficiency LED Lighting

Freezer: 5.8 cu. ft.

- 1 Large Opaque Freezer Bin with Divider
- Auto Pull-Out Upper Drawer Bin
- Automatic Ice Maker

Volt/Amps	115V / 60Hz / 3.0A
Power Cord Length	2 meters

Warranty

One (1) Year Parts and Labour on Refrigerator
Ten (10) Years Parts on Digital Inverter Compressor

Product Dimensions & Weight (WxHxD)

Dimensions (WxHxD with hinges, handles and doors):

32 1/8" x 70" x 28 1/8"

Dimensions (WxHxD without hinges and door):

32 1/8" x 68 7/8" x 24 1/2"

Dimensions (WxHxD with hinge and door, no handle):

32 1/8" x 70" x 28 1/8"

Weight: 205 lbs (93 Kg)

Shipping Dimensions & Weight (WxHxD)

Dimensions: 34 5/8" x 75" x 30 1/2"

Weight: 223 lbs (101 Kg)

Colour

- Fingerprint Resistant Stainless Steel
- Fingerprint Resistant Black Stainless Steel

Model

- RF18A5101SR
- RF18A5101SG

UPC Code

- 887276455167
- 887276465449