

Café™ 5.7 Cu. Ft. Built-In Dual-Drawer Refrigerator

CDE06RP4NW2 / CDE06RP3ND1 / CDE06RP2NS1

CAFÉ

DISTINCT BY DESIGN™



CDE06RP4NW2
Matte White with
Brushed Bronze handles

ALSO
AVAILABLE IN



CDE06RP2NS1
Stainless Steel with
Brushed Stainless
handles



CDE06RP3ND1
Matte Black with
Brushed Stainless
handles

FEATURES

Control Type	Electronic
Interior Lighting	LED
Leveling System	Leveling Legs
Defrost Type	Auto
Defrost Water Drain	Yes
Sabbath Mode	Yes
Sort Capacity	5.7

CAPACITY

Total Capacity (cubic feet)	5.7 cu ft
-----------------------------	-----------

WEIGHTS & DIMENSIONS

Approximate Shipping Weight	135 lb
Net Weight	126 lb
Depth Without Handle	23 3/4 in
Overall Depth	26 in
Overall Height	33 7/8 in
Overall Width	23 7/8 in



FEATURES & BENEFITS

Impress your guests every time you open the drawers with an attractive **stainless steel interior** that is also easy to clean.

Never let grabbing a quick snack interrupt your conversations, thanks to **soft-close drawers** that slide quietly closed.

Favorite wines are always perfectly chilled and ready to serve with a large **5.7 cu. ft. capacity** that easily holds upright bottles.

Keep all your fresh foods and drinks organized with an **adjustable divider** that maximizes flexibility and storage capacity in both drawers.

Fresh vegetables and craft beers are always stored in their ideal climate, thanks to an **exact temperature control** that chills items between 34° and 45° F.

Sharable foods are easy to find and easy to serve with **LED lighting** that provides clear, bright light throughout the drawers.

APPEARANCE

Exterior design	Flat doors
Handle design	Café

Café™ 5.7 Cu. Ft. Built-In Dual-Drawer Refrigerator

CDE06RP4NW2 / CDE06RP3ND1 / CDE06RP2NS1

CAFÉ

DISTINCT BY DESIGN™

WARRANTY

Parts warranty	Limited 1-year entire appliance
Labor warranty	Limited 1-year entire appliance
Warranty notes	See written warranty for full details

DIMENSIONS

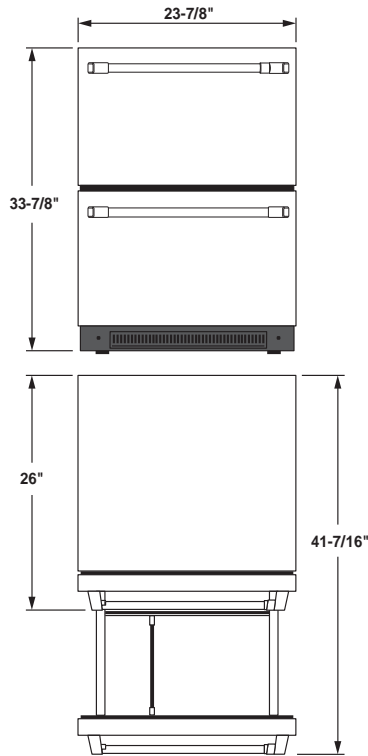

ADDITIONAL ACCESSORIES



CXQD2H2PNBZ
Brushed Bronze
2 handles
(Standard on Matte White)



CXQD2H2PNSS
Brushed Stainless
2 handles
(Standard on Matte Black
and Stainless Steel)



CXQD2H2PNBT
Brushed Black
2 handles



CXQD2N2PNCU
Brushed Copper
2 handles