

AutoShelter RoundTop® 1015

10' x 15' x 8' / 3 x 4,6 x 2,4 m

TEMPORARY STRUCTURE
STRUCTURE TEMPORAIRE
ESTRUCTURA TEMPORAL



= Helpful information
= Informations utiles
= Información útil

Green / Vert / Verde	62589
Sandstone / Grès / Arenisca	62689

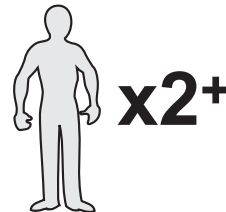
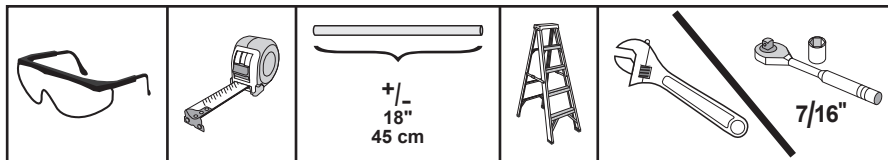
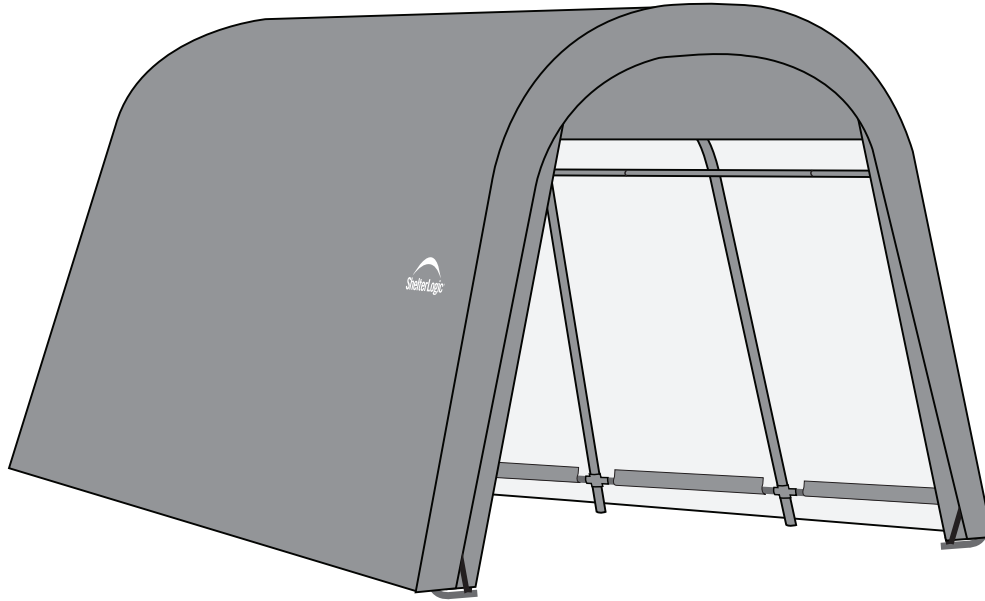

150 Callender Road
Watertown, CT 06795
www.shelterlogic.com

1-800-524-9970

Canada:
1-800-559-6175



ATTENTION: This shelter product is manufactured with quality materials. It is designed to fit the ShelterLogic® Corp. custom fabric cover included. ShelterLogic® Corp. Shelters offer storage and protection from damage caused by sun, light rain, tree sap, animal - bird excrement and light snow. Please anchor this ShelterLogic® Corp. structure properly. See manual for more anchoring details. Proper anchoring, keeping cover tight and free of snow and debris is the responsibility of the consumer. Please read and understand the installation detail, warnings and cautions prior to beginning installation. If you have any questions call the customer service number listed below. Please refer to the warranty card inside this package.

DANGER: Prior to installation, consult with all local municipal codes regarding installation of temporary shelters. Choose the location of your shelter carefully. **DANGER: Keep away from electrical wires.** Check for overhead utility lines, tree branches or other structures. Check for underground pipes or wires before you dig. DO NOT install near roof lines or other structures that could shed snow, ice or excessive rain on/off your shelter. DO NOT hang objects from the roof or support cables.

WARNING: Risk of fire. DO NOT smoke or use open flame devices (including grills, fire pits, deep fryers, smokers or lanterns, etc.) in or around the shelter. DO NOT store flammable liquids (gasoline, kerosene, propane, etc.) in or around your shelter. Do not expose top or sides of the shelter to open fire or other flame source.

CAUTION: Use CAUTION when erecting the frame. Use safety goggles during installation. Secure and bolt together overhead poles during assembly. Be aware of pole ends.

PROPER ANCHORING AND INSTALLATION OF FRAME: PROPER ANCHORING OF THE FRAME IS THE RESPONSIBILITY OF THE CONSUMER.

ShelterLogic® Corp. is not responsible for damage to the unit or the contents from acts of nature. Any shelter that is not anchored securely has the potential to fly away causing damage, and is not covered under the warranty. Periodically check the anchors to ensure stability of shelter. ShelterLogic® Corp. cannot be responsible for any shelter that blows away. **NOTE:** Your shelter's cover can be quickly removed and stored prior to severe weather conditions. If strong winds or severe weather is forecast in your area, we recommend removal of cover.

REPLACEMENT PARTS, ASSEMBLY, SPECIAL ORDERS: Genuine ShelterLogic® Corp. replacement parts and accessories are available from the factory, including anchoring kits for nearly any application, replacement covers, wall and enclosure kits, vent and light kits, frame parts, zippered doors and other accessories. All items are shipped factory direct to your door.

QUESTIONS - CLAIMS - REPLACEMENT PARTS? CALL OUR CUSTOMER SERVICE HOTLINE:

U.S.A.: 1-800-524-9970

INTERNATIONAL: 001-860-945-6442

CANADA: 1-800-559-6175

HOURS OF OPERATION: MON-FRI 8:00AM-8:00PM ET, SAT-SUN 8:00AM-4:30PM ET.

CARE AND CLEANING: A tight cover ensures longer life and performance. Always maintain a tight cover. Loose fabric can accelerate deterioration of cover fabric. Immediately remove any accumulated snow or ice from the roof structure with a broom, mop or other soft-sided instrument. Use extreme caution when removing snow from cover- always remove from outside the structure. DO NOT use hard-edged tools or instruments like rakes or shovels to remove snow. This could result in punctures to the cover. DO NOT use bleach or harsh abrasive products to clean the fabric cover. Cover is easily cleaned with mild soap and water.

WARRANTY: This shelter carries a limited warranty against defects in workmanship. ShelterLogic® Corp. warrants to the Original Purchaser that if properly used and installed, the product and all associated parts, are free from manufacturer's defects for a period of 1 YEAR FOR COVER FABRIC, END PANELS, AND FRAMEWORK. Warranty period is determined by date of shipment from ShelterLogic® Corp. for factory direct purchases or date of purchase from an authorized reseller, (please save a copy of your purchase receipt). If this product or any associated parts are found to be defective or missing at the time of receipt, ShelterLogic® Corp. will repair or replace, at it's option, the defective parts at no charge to the original purchaser. Replacement parts or repaired parts shall be covered for the remainder of the Original Limited Warranty Period. All shipping costs will be the responsibility of the customer. You must save the original packaging materials for shipment back. If you purchased from a local dealer, all claims must have a copy of original receipt. After purchase, please fill out and return warranty card for product registration. Please see warranty card for more details. This warranty gives you specific legal rights, and you may also have other rights which vary from state to state.

Covered by U.S. Patents and patents pending: 6,871,614; 6,994,099; 7,296,584; D 430,306; D 415,571; D 414,564; D 409,310; D 415,572

03312014

ATTENTION : Cet abri est fabriqué avec des matériaux de qualité. Il est conçu en fonction de la toile adaptée ShelterLogic® Corp. fournie. Les abris ShelterLogic® Corp. offrent de l'espace de rangement et de la protection contre les dommages causés par le soleil, la pluie légère, la sève, les excréments d'animaux ou d'oiseaux et la neige légère. Veuillez ancrer adéquatement cette structure ShelterLogic® Corp. Consultez le guide pour connaître les détails sur l'ancrage. Il incombe à l'utilisateur d'assurer un ancrage adéquat et de garder la toile bien tendue et exempte de neige ou de débris. Veuillez lire et vous assurer de bien comprendre les détails de l'installation, les avertissements et les mises en garde avant d'entreprendre l'installation. Pour toute question, téléphonez au service à la clientèle au numéro ci-dessous. Veuillez aussi consulter la fiche de garantie se trouvant dans l'emballage.

DANGER : Avant d'entreprendre l'installation, vérifiez tous les règlements municipaux concernant les abris temporaires. Choisissez soigneusement l'emplacement de l'abri. **DANGER :** Tenez-vous éloigné des fils électriques. Évitez les lignes électriques, les branches d'arbres et les autres types de structures. Avant de creuser, vérifiez la présence de tuyaux ou de fils enfouis. N'installez PAS cet abri à proximité d'un toit ou de toute autre structure pouvant laisser tomber de la neige, de la glace ou des débris. Ne suspendez AUCUN objet au toit ou aux câbles de soutien.

AVERTISSEMENT : Risque d'incendie. Ne fumez PAS et n'utilisez AUCUN dispositif produisant des flammes (p. ex., un barbecue, un foyer, une friteuse, un four ou une lanterne) à proximité de l'abri. Ne rangez PAS des liquides inflammables (essence, kérosène, propane, etc.) à proximité de l'abri. N'exposez pas le dessus ou les parois de l'abri au feu ou à toute source d'incendie.

ATTENTION : Soyez PRUDENT au moment de monter l'armature. Portez des lunettes de sécurité durant l'installation. Boulonnez les mâts supérieurs durant l'assemblage. Prenez garde aux extrémités des mâts.

ANCRAGE ET INSTALLATION DE L'ARMATURE : IL INCOMBE À L'UTILISATEUR D'ASSURER L'ANCRAGE ADÉQUAT DE L'ARMATURE.

ShelterLogic® Corp. n'assume aucune responsabilité pour les dommages causés à l'abri ou à son contenu par les catastrophes naturelles. Tout abri n'étant pas ancré solidement risque de s'envoler et de causer des dommages, ce qui n'est pas couvert par la garantie. Vérifiez périodiquement les ancrages pour assurer la stabilité de l'abri. ShelterLogic® Corp. ne peut être tenue responsable d'un abri qui s'envole. **REMARQUE :** La toile de l'abri peut être retirée rapidement pour être entreposée en prévision de mauvais temps. Si des vents forts ou du mauvais temps sont prévus pour votre région, nous vous recommandons d'enlever la toile de l'abri.

PIÈCES DE RECHANGE ET COMMANDES SPÉCIALES :

Des pièces de rechange et des accessoires d'origine ShelterLogic® Corp. sont disponibles à l'usine, notamment des nécessaires d'ancrage pour presque toute utilisation, des toiles de rechange, des ensembles de parois, des nécessaires d'aération ou d'éclairage, des pièces d'armature, des portes à glissière, etc. Tous ces articles sont expédiés directement chez vous à partir de l'usine.

QUESTIONS - RÉCLAMATIONS - PIÈCES DE RECHANGE? APPELLEZ NOTRE SERVICE CLIENTÈLE HOTLINE:

U.S.A.: 1-800-524-9970

INTERNATIONAL: 001-860-945-6442

CANADA: 1-800-559-6175

HEURES D'OUVERTURE: LUN-VEN 8:00AM-8:00PM ET, SAM-DIN 8:00AM-4:30PM ET.

ENTRETIEN ET NETTOYAGE : Une toile bien tendue assure une longue durée utile. Gardez toujours la toile bien tendue. Une toile desserrée accélère la détérioration du tissu. Enlevez sans attendre toute accumulation de débris sur le toit à l'aide d'un balai, d'une vadrouille ou d'un autre outil souple. Soyez très prudent au moment d'enlever la neige de la toile. Enlevez-la toujours à partir de l'extérieur de la structure. N'utilisez PAS d'outils rigides comme des râtaeux ou des pelles pour enlever la neige, car ils risqueraient de perforer la toile. N'utilisez PAS de javellissants ou d'abrasifs pour nettoyer la toile. Utilisez tout simplement de l'eau savonneuse pour nettoyer la toile.

GARANTIE : Cet abri offre une garantie limitée contre les défauts de fabrication. ShelterLogic® Corp. garantit à l'acheteur initial que s'il est installé et utilisé adéquatement, cet article et toutes ses pièces sont exempts de défaut de fabrication pendant une période de : 1 AN POUR LA TOILE, LES PANNEAUX D'EXTRÉMITÉ ET L'ARMATURE. La période de garantie est calculée à partir de la date d'expédition par ShelterLogic® Corp. pour les achats faits directement à l'usine ou de la date d'achat chez un revendeur autorisé (veuillez conserver votre reçu d'achat). Si cet article ou une de ses pièces est jugé défectueux ou qu'il est manquant au moment de la réception, ShelterLogic® Corp. réparera ou remplacera, à sa discrétion, toute pièce défectueuse sans frais pour l'acheteur initial. Toute pièce remplacée ou réparée demeure couverte durant le reste de la période de garantie limitée initiale. Tous les frais d'expédition sont à la charge du client. Veuillez conserver le matériel d'emballage initial pour l'envoi de retour. Pour les achats faits chez un marchand local, toute réclamation doit être accompagnée d'une copie du reçu initial. Après l'achat, veuillez remplir et expédier la fiche de garantie pour inscrire l'article. Veuillez consulter la fiche de garantie pour obtenir de plus amples renseignements. Cette garantie vous donne des droits juridiques spécifiques, et vous pouvez également avoir d'autres droits qui varient d'un état à l'autre.

Brevets Américains et brevets en instance : 6,871,614; 6,994,099; 7,296,584; D 430,306; D 415,571; D 414,564; D 409,310; D 415,572

ATENCIÓN: Este producto de toldo está fabricado con materiales de calidad. Está diseñado para adaptarse a la cubierta personalizada incluida de ShelterLogic® Corp. Los toldos ShelterLogic® Corp. le ofrecen almacenamiento y protección de los daños causados por el sol, lluvia ligera, savia de árboles, animales - excrementos de aves y nieve ligera. Por favor ancle este toldo ShelterLogic® Corp. correctamente. Consulte el manual para más detalles de anclaje. El anclaje adecuado, el mantener la cubierta apretada y libre de nieve y los desechos es la responsabilidad del consumidor. Por favor, lea y entienda los detalles de instalación, advertencias y precauciones antes de comenzar la instalación. Si usted tiene alguna pregunta, llame al número de servicio al cliente que aparece a continuación. Por favor, consulte la tarjeta de garantía dentro de este empaque.

PELIGRO: Antes de su instalación, consulte todos los códigos municipales locales con respecto a la instalación de toldos temporales. Elija la ubicación del toldo cuidadosamente. **PELIGRO:** Manténgala alejada de cables eléctricos. Revise que no haya cables de utilidad, ramas de árboles u otras estructuras. NO lo instale cerca de cables del techo u otras estructuras que puedan acumular nieve, hielo o deslizamientos excesivos hacia la carpa. NO cuelgue objetos del techo o cables de soporte.

ADVERTENCIA: Riesgo de incendio. NO lo use con artefactos humeantes o de flama abierta (incluyendo asadores, fogones, freidoras, ahumadores o linterna de combustible). NO almacene líquidos inflamables (gasolina, queroseno, gas propano, etc.) dentro o cerca de la carpa. No lo exponga a ninguna fuente de flama abierta.

PRECAUCIÓN: Use PRECAUCIÓN cuando esté parando el marco. Use protección ocular durante la instalación. Asegure y atornille los postes superiores durante el ensamble. Tenga cuidado de los extremos de los postes.

ANCLAJE E INSTALACIÓN APROPIADA DEL MARCO: EL ANCLAJE APROPIADO DEL MARCO ES LA RESPONSABILIDAD DEL CONSUMIDOR.

ShelterLogic® Corp. no es responsable por daños al toldo o los contenidos guardados debajo de ella provenientes de actos de la naturaleza. Aquel toldo que no esté anclado de manera segura tienen el potencial de volar causando daños. Periódicamente revise el anclaje para asegurar la estabilidad del toldo. El sistema de anclaje preferido es el uso de estacas atornilladas a cemento para el marco. ShelterLogic® Corp. no puede ser responsable si la carpa vuela. **NOTA:** Su marco y cubierta del toldo pueden ser removidos y almacenados rápidamente antes de experimentar condiciones severas del clima. Si hay pronósticos de fuertes vientos y climas severos en su área, le recomendamos remover la cubierta.

PARTES DE REPUESTO, ENSAMBLE, ORDENES ESPECIALES:

Partes de repuesto y accesorios genuinos de ShelterLogic® Corp. están disponibles de fábrica, incluyendo juegos de anclaje para casi cualquier aplicación, cubiertas de repuesto, parades y juegos de parades, ventillas y juegos de luz, partes para marco, puertas con cierre y otros accesorios. Todos los artículos serán enviados de fábrica directamente a su puerta.

CONSULTAS Y RECLAMACIONES - PIEZAS DE REPUESTO? LLAME A NUESTRA LINEA DE SERVICIO:

U.S.A.: 1-800-524-9970

INTERNATIONAL: 001-860-945-6442

CANADA: 1-800-559-6175

HORAS DE OPERACIÓN: LUN-VEN 8:00AM-8:00PM ET, SÁB-DOM 8:00AM-4:30PM ET.

CUIDADO Y LIMPIEZA: Un toldo apretado asegurará una larga vida y desempeño. Siempre mantenga una cubierta apretada. Un material suelto puede acelerar la deterioración del toldo. Inmediatamente remueva cualquier acumulación de agua de lluvia, nieve o hielo de la estructura con una escoba, trapeador u otro instrumento con lado suave. Use extremo cuidado cuando remueva la nieve de la cubierta, siempre remuevala desde afuera de la estructura. NO use cloro o productos abrasivos para limpiar la carpa. La cubierta puede limpiarse fácilmente con agua y jabón suave.

GARANTÍA: Este cobertizo cuenta con una garantía limitada contra defectos de fabricación. ShelterLogic® Corp. garantiza al comprador original que si se utilizan e instalan adecuadamente, el producto y todas las partes asociadas, están libres de defectos de fabricación por un período de:

1 AÑO PARA LA CUBIERTA DE TELA, PANELES DE EXTREMO Y ESTRUCTURA.

El período de garantía se determina por la fecha de envío de ShelterLogic® Corp. para la compra directa de la fábrica o la fecha de compra a un distribuidor autorizado, (por favor, guarde una copia de su recibo de compra). Si este producto o cualquier parte asociada se encuentra defectuosa o no en el momento de la recepción, ShelterLogic® Corp. reparará o reemplazará, a que la opción, las partes defectuosas sin costo alguno para el comprador original. Las piezas de repuesto o pieza reparada serán cubiertos por el resto de la original periodo de Garantía Limitada. Todos los gastos de envío correrán a cargo del cliente. Debe guardar los materiales de embalaje originales para su envío posterior. Si usted compró a un distribuidor local, todas las reclamaciones debe tener una copia del recibo original. Después de la compra, por favor complete y devuelva la tarjeta de garantía para registrar el producto. Por favor, consulte la tarjeta de garantía para obtener más detalles. Esta garantía le otorga derechos legales específicos, y usted también puede tener otros derechos que varían de estado a estado.

Cubierto por las Patentes de E.U.A. y patentes pendientes: 6,871,614; 6,994,099; 7,296,584; D 430,306; D 415,571; D 414,564; D 409,310; D 415,572

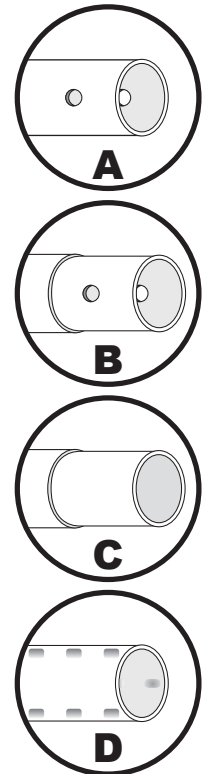
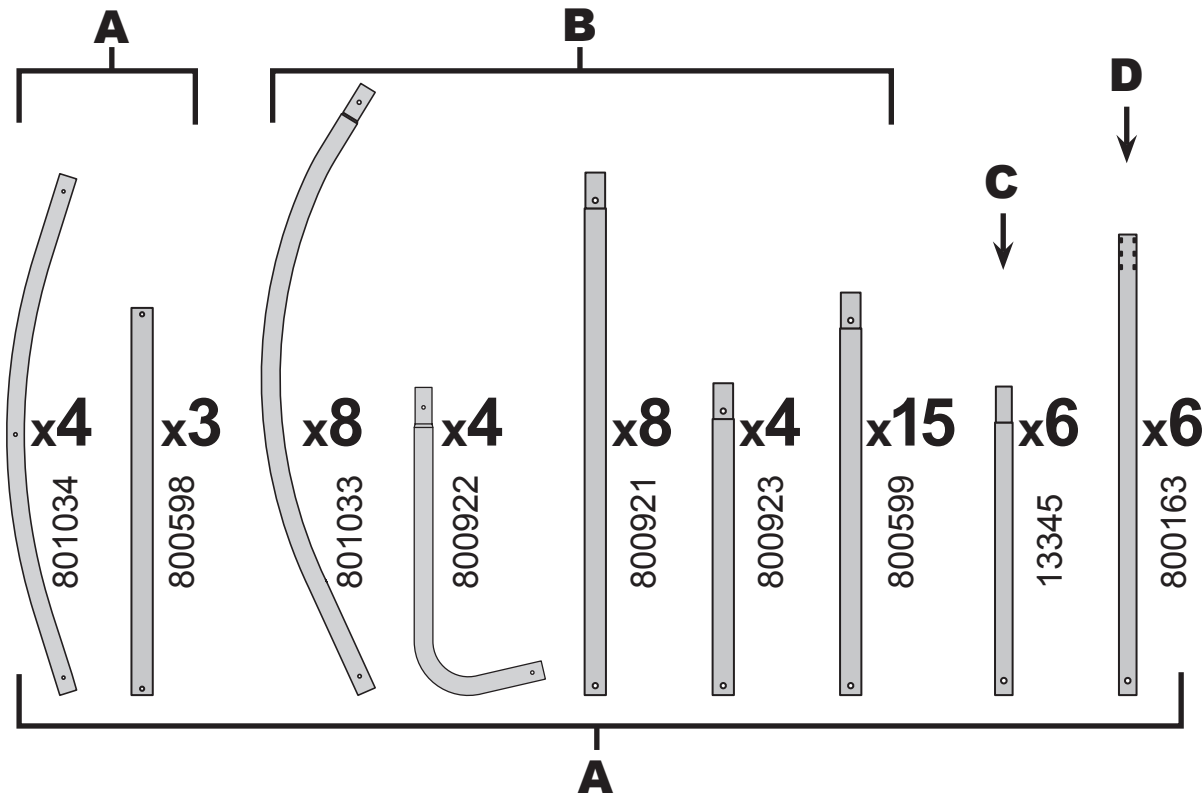
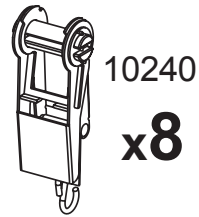
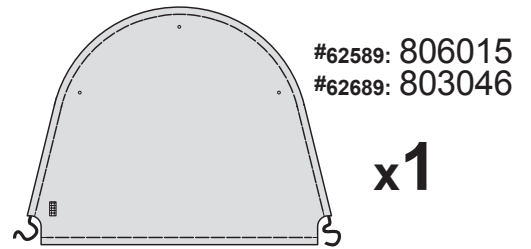
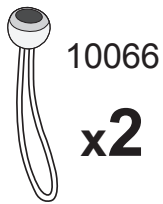
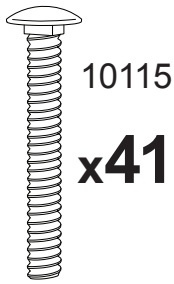
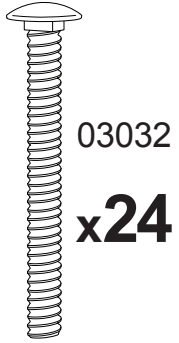
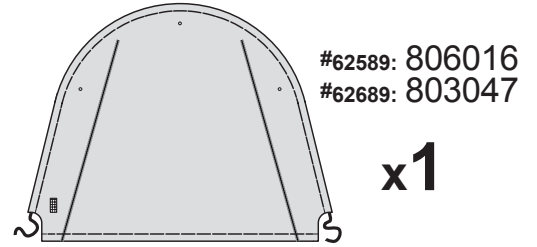
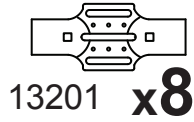
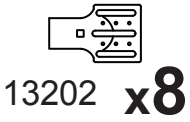
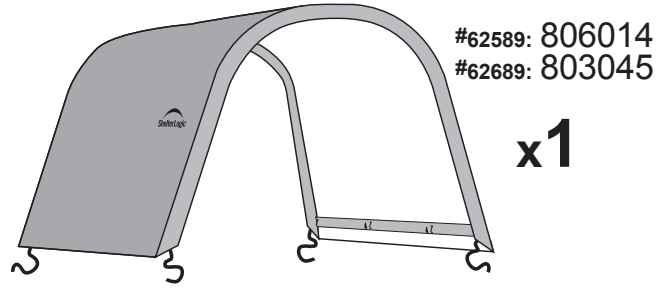
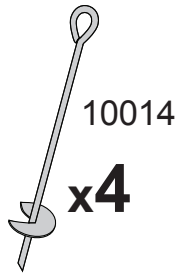
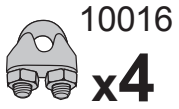

1.

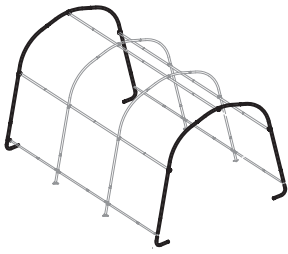
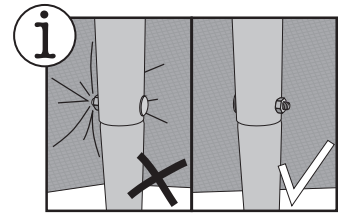
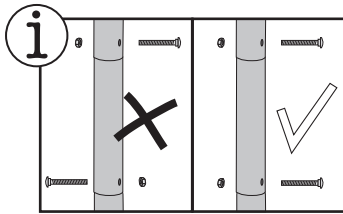
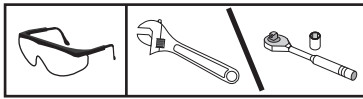

x2

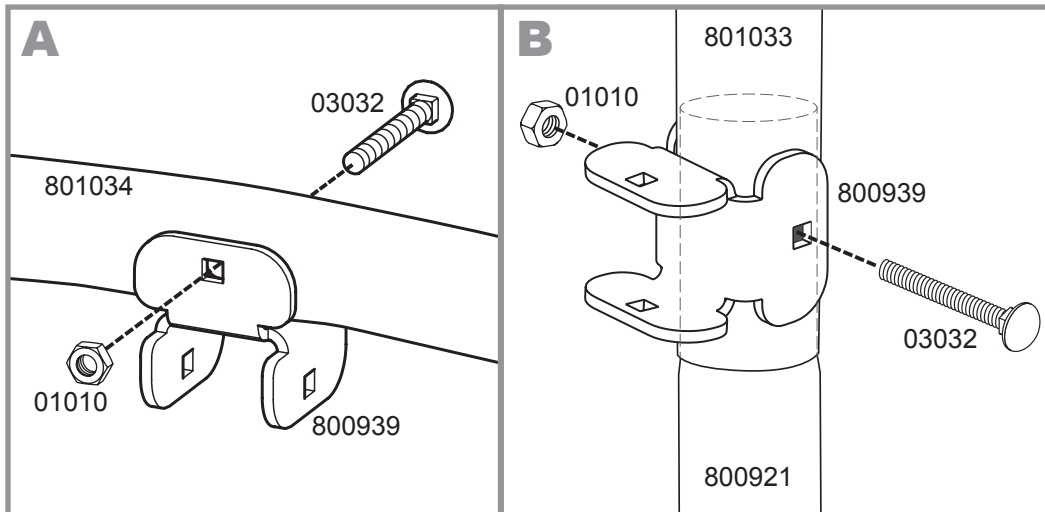
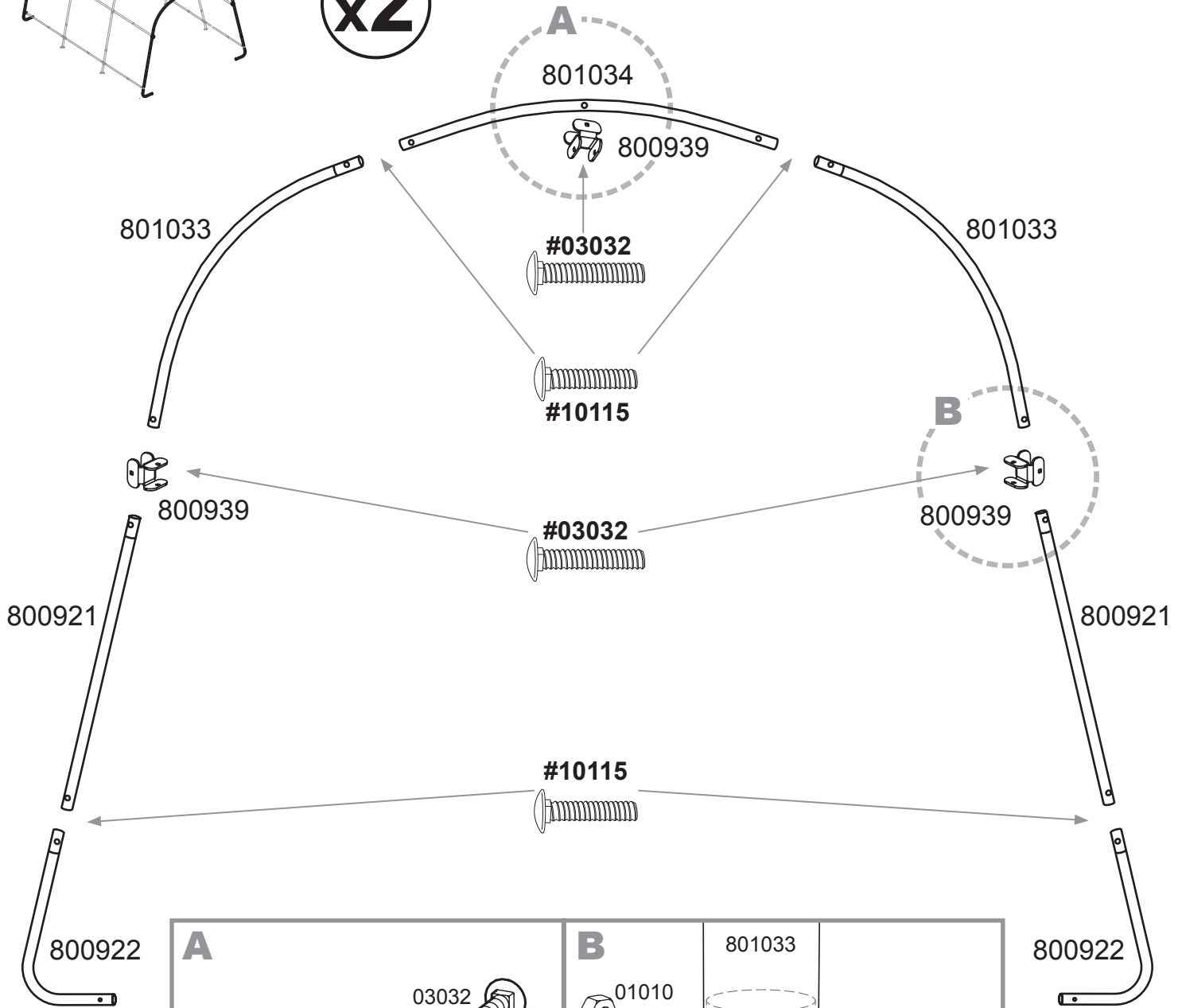

2.

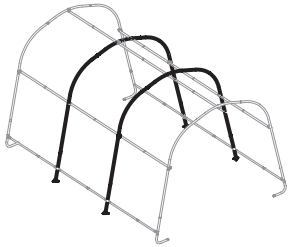
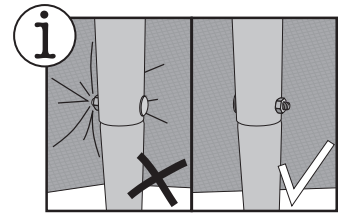
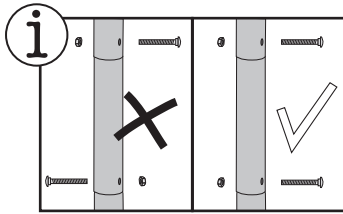
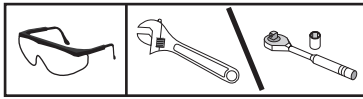

x2

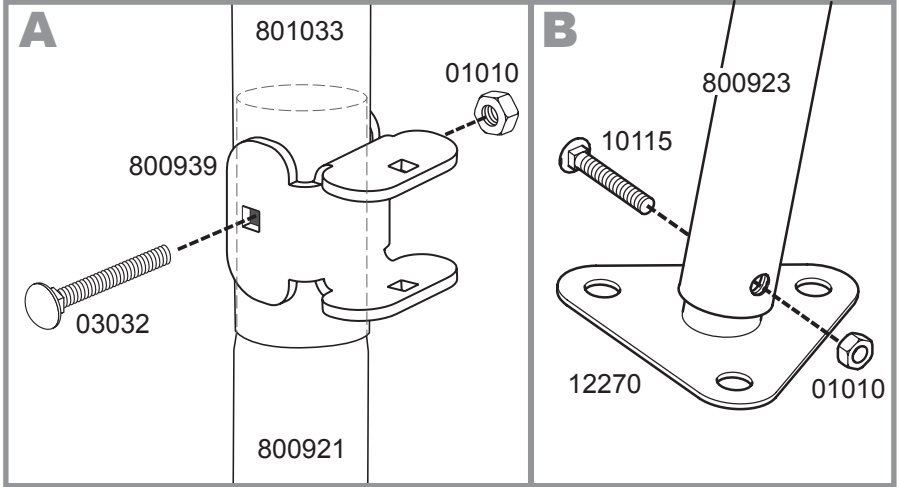
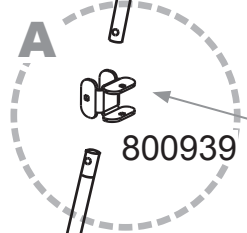
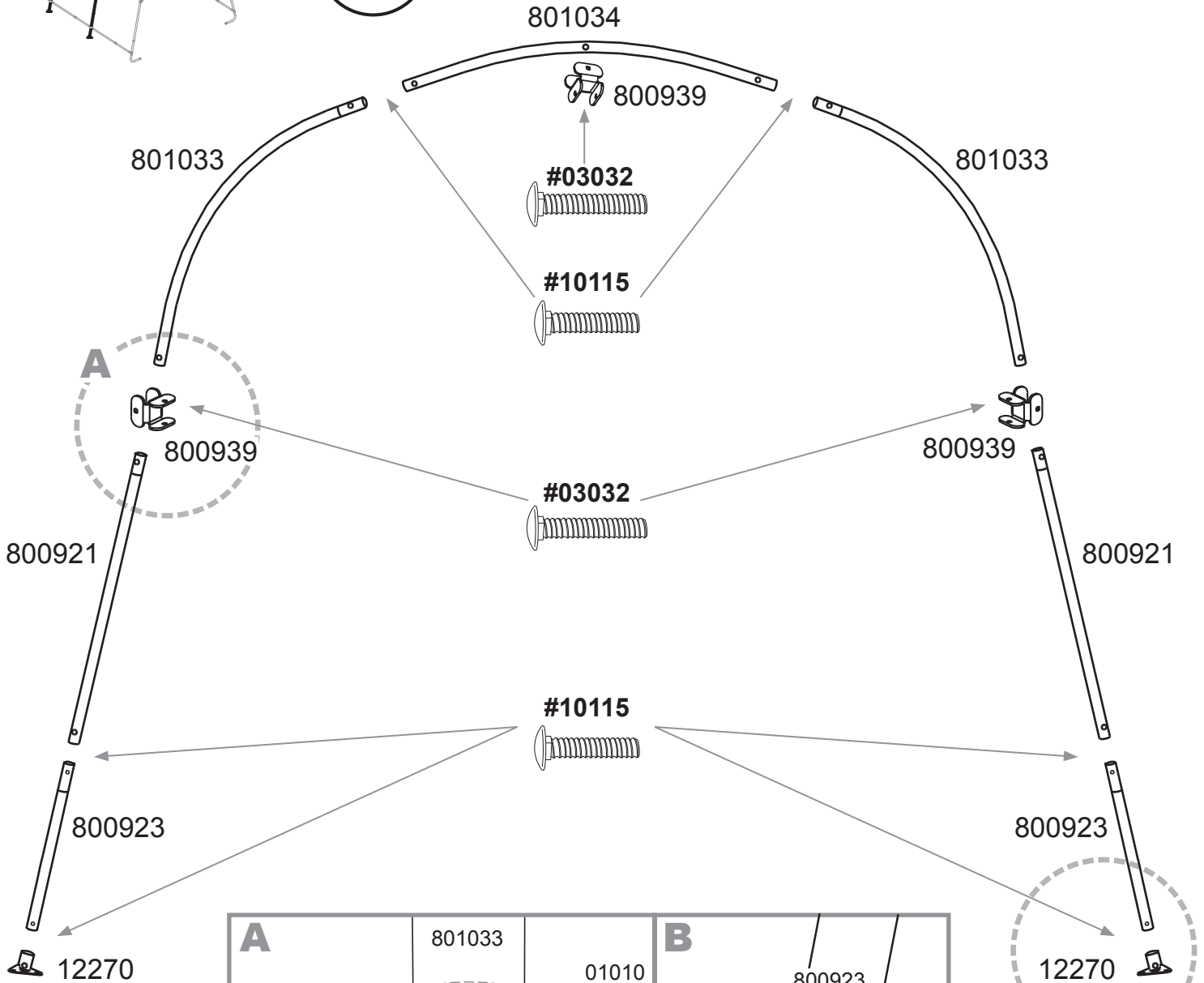

3.

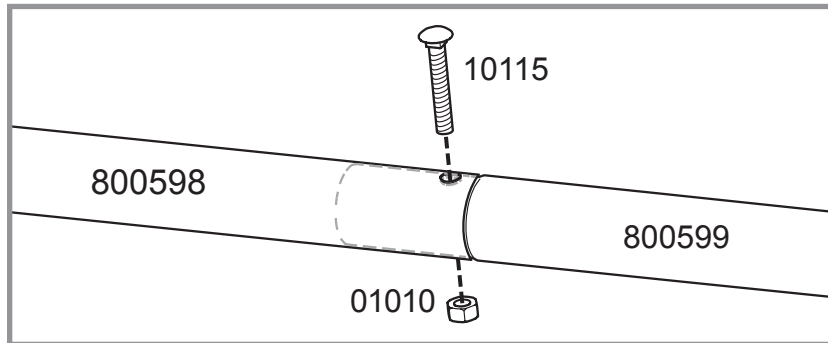
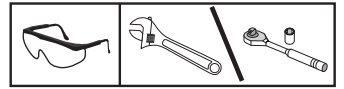

x3

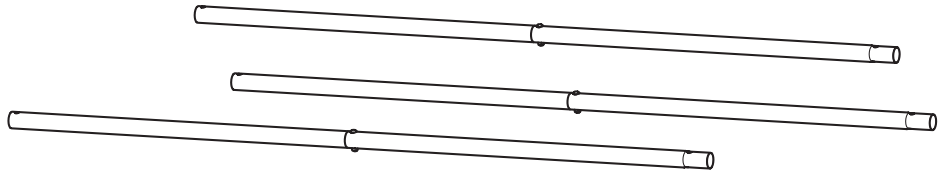

4.

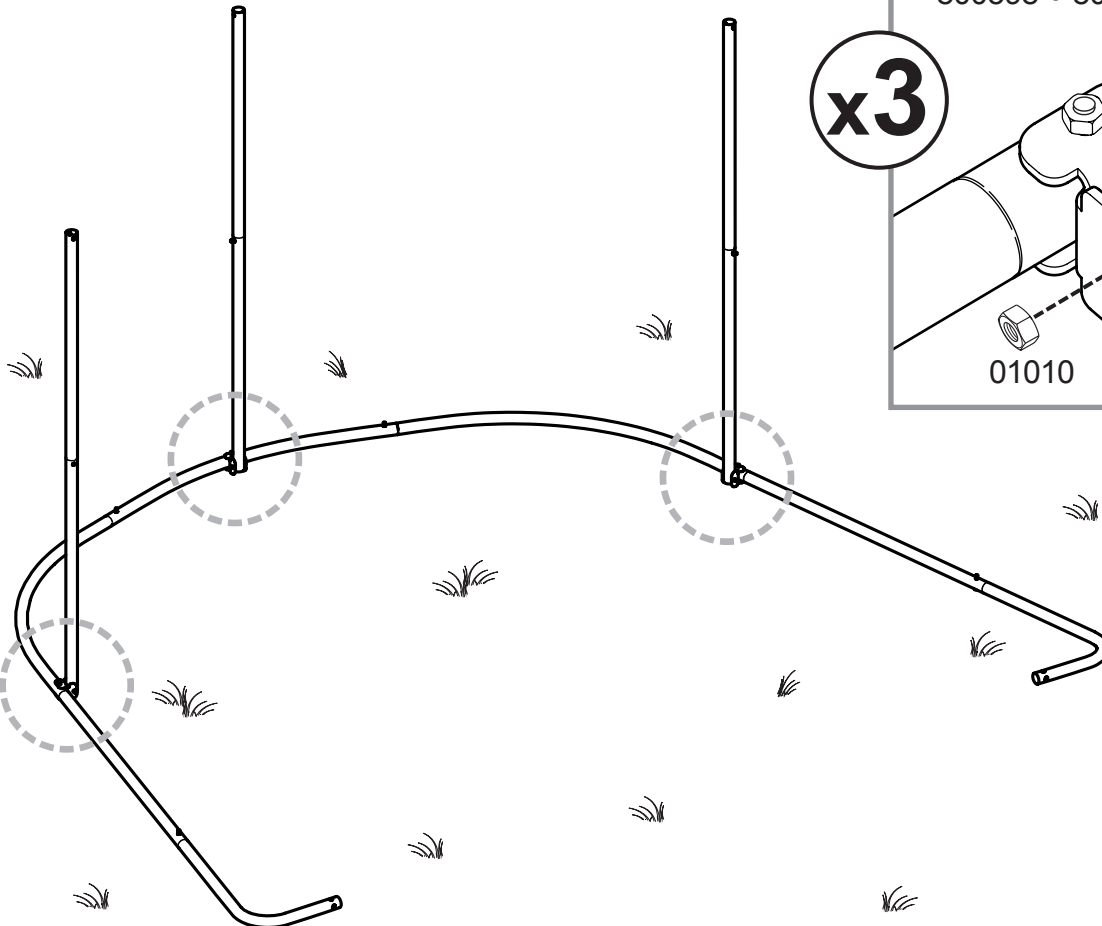

x3

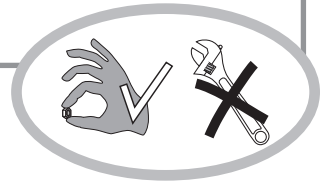
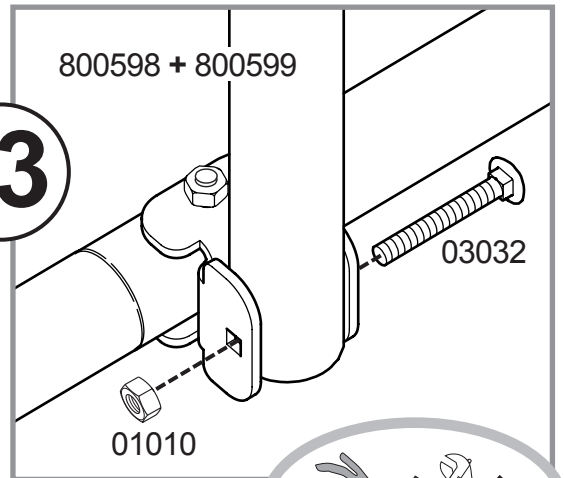

5.

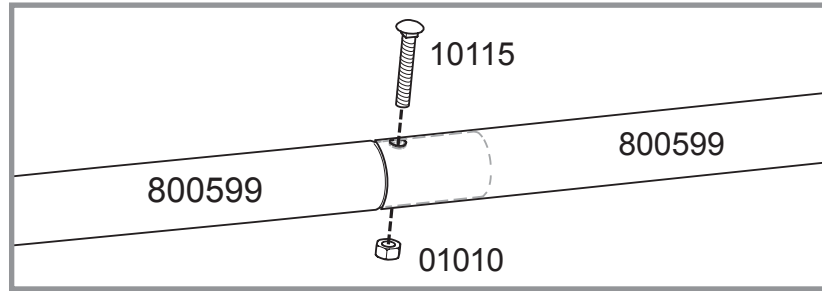
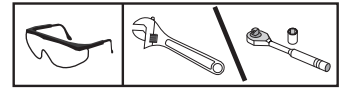

x6

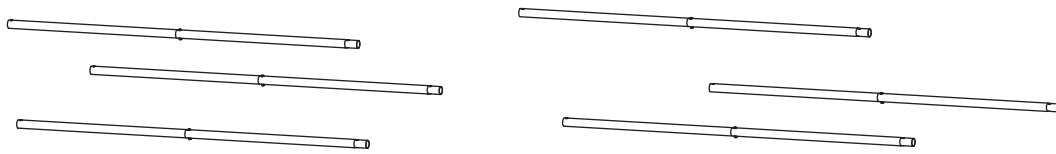

6.

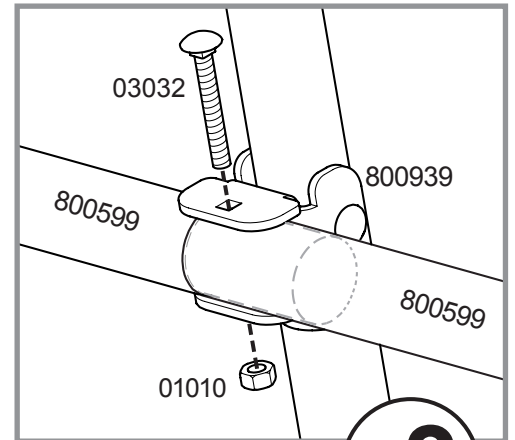
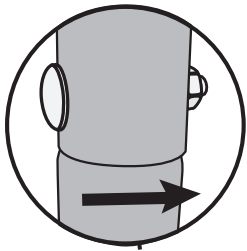
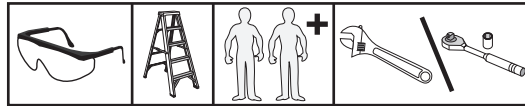

x3

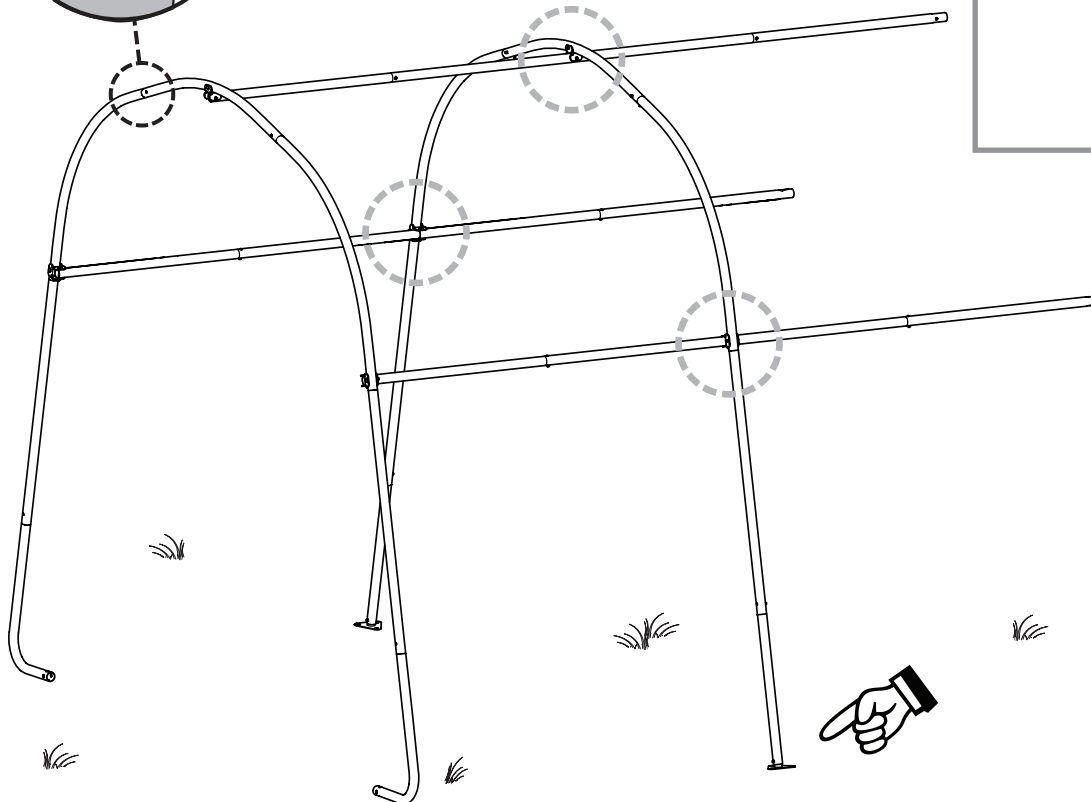

7.

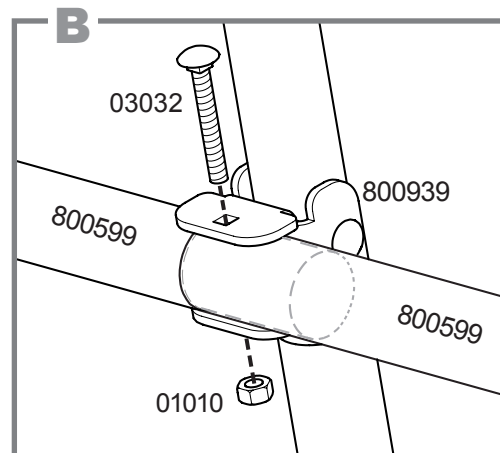
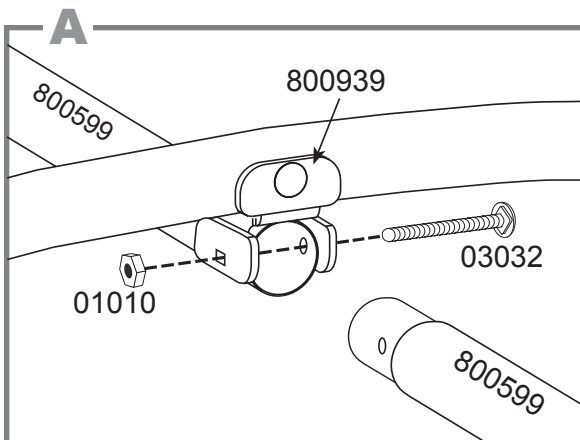
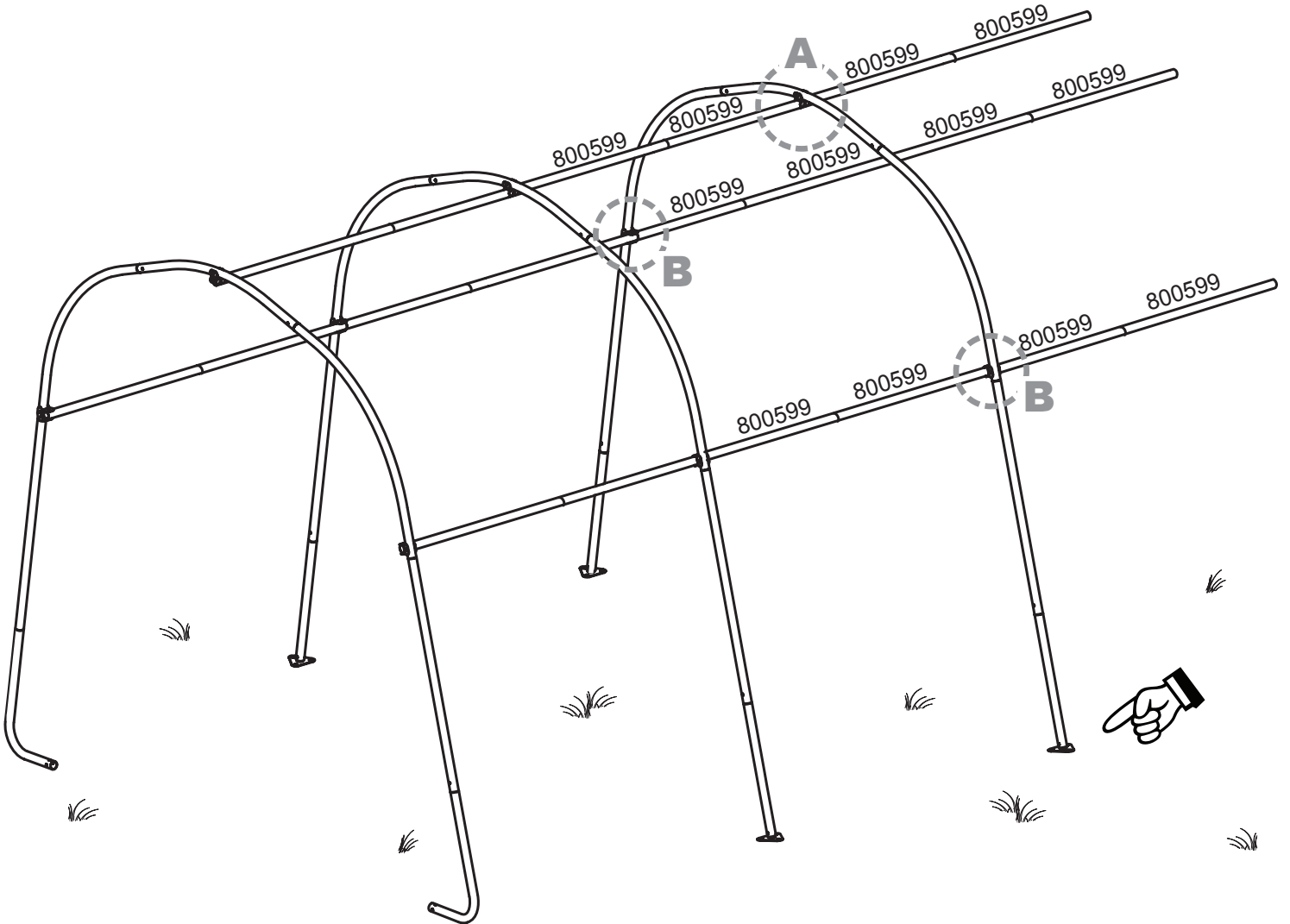
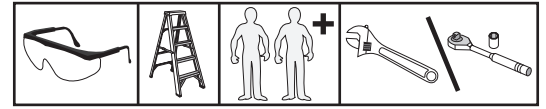
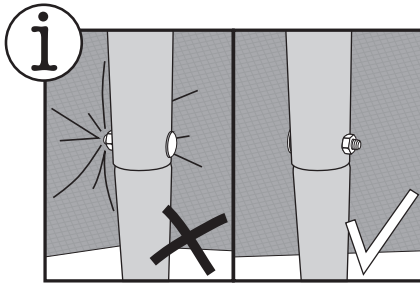

8.

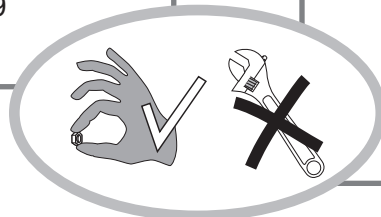
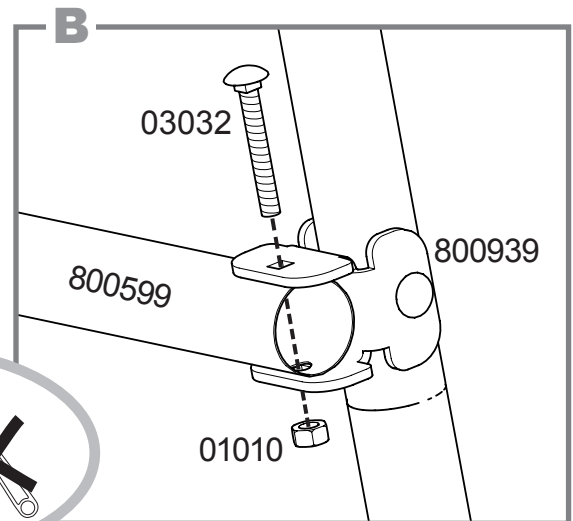
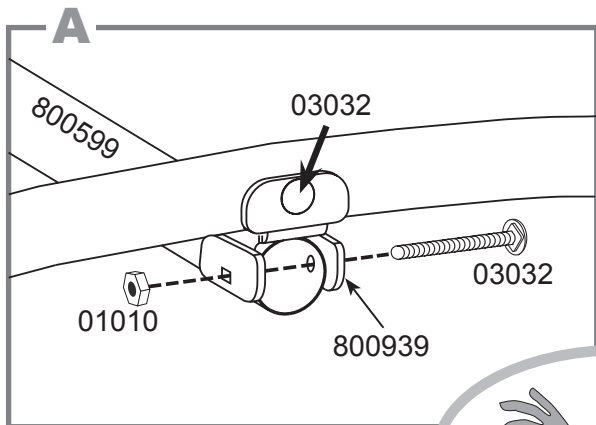
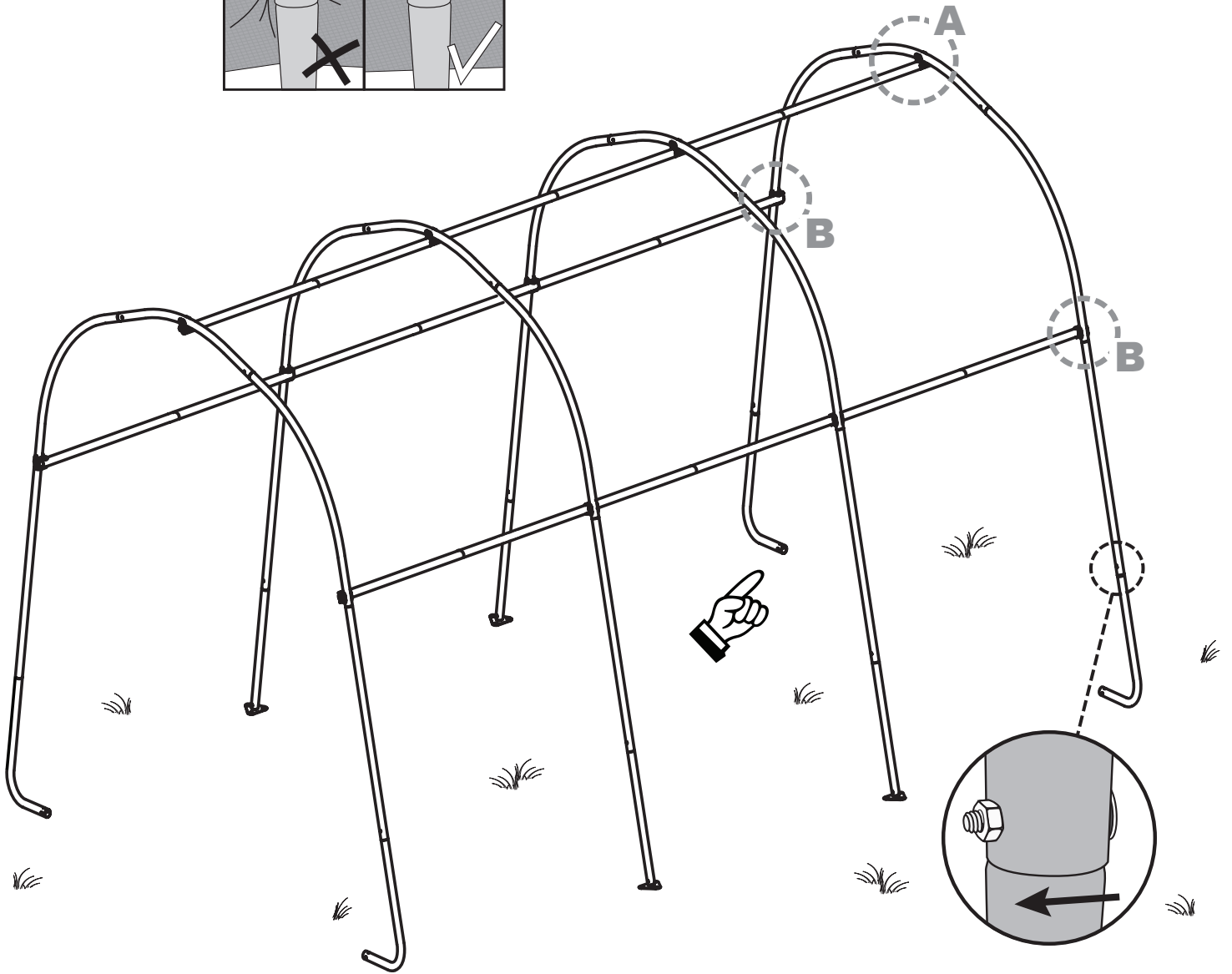
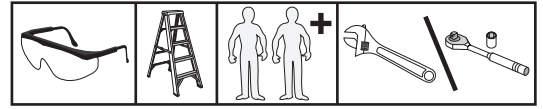
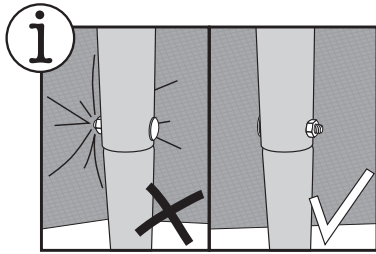

9.

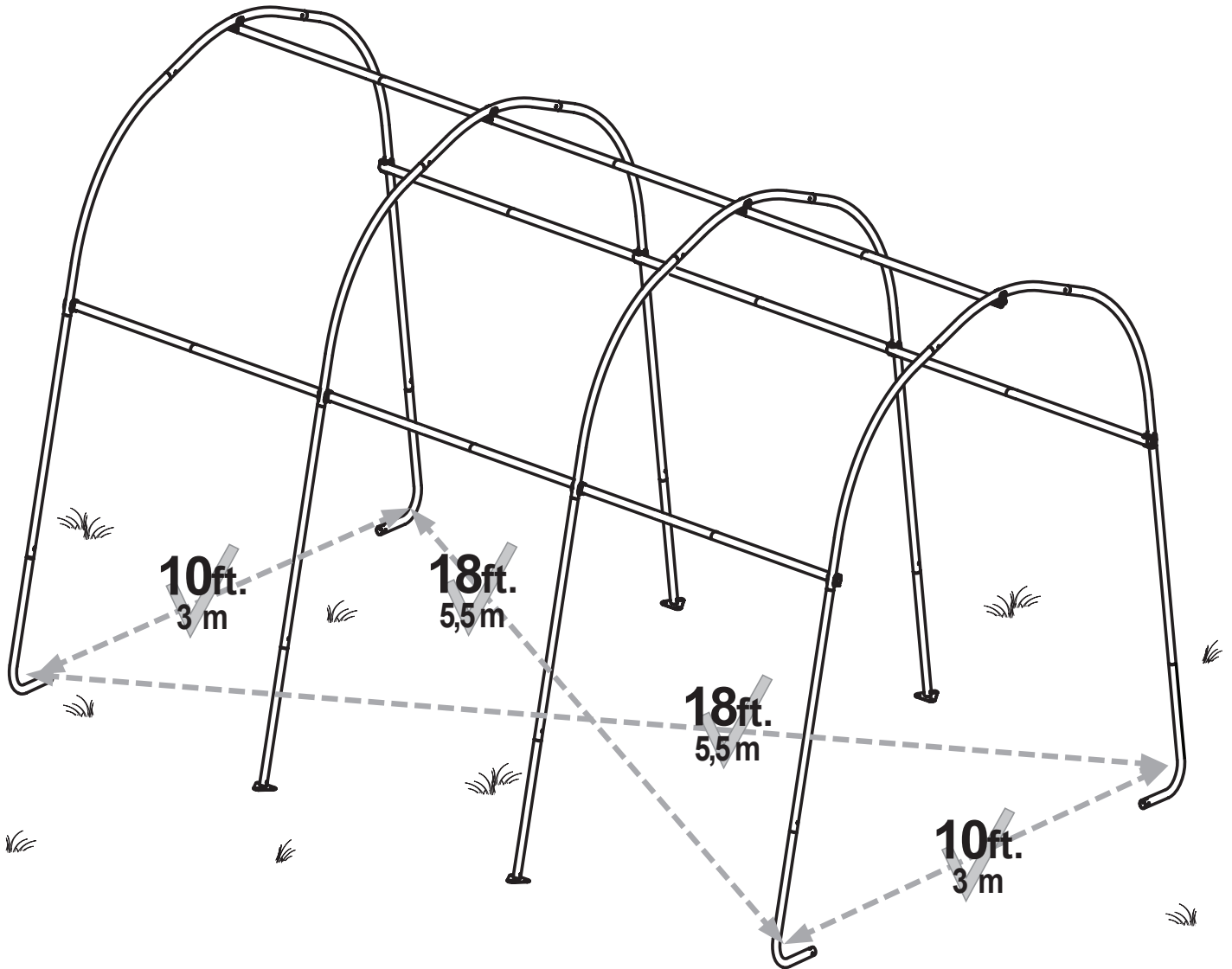
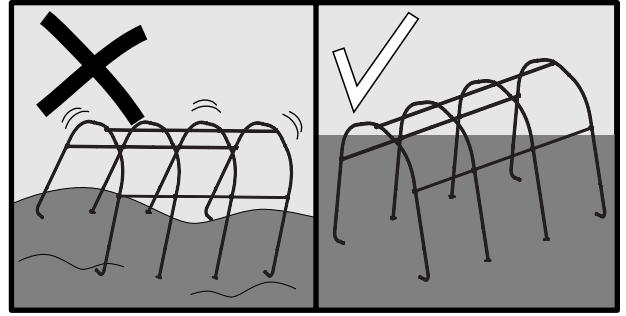
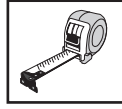

✓ +/- 1"

10.

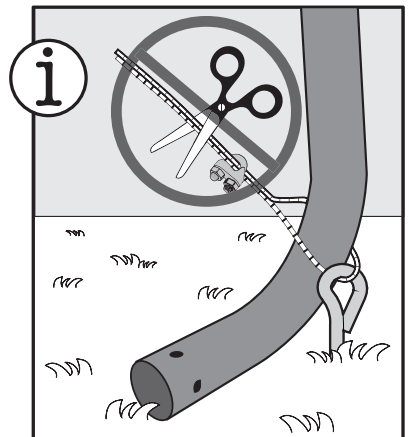
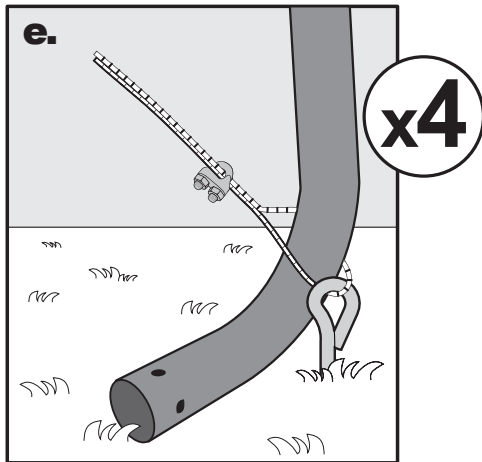
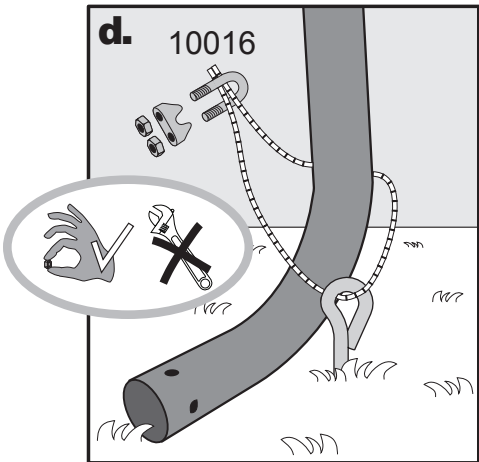
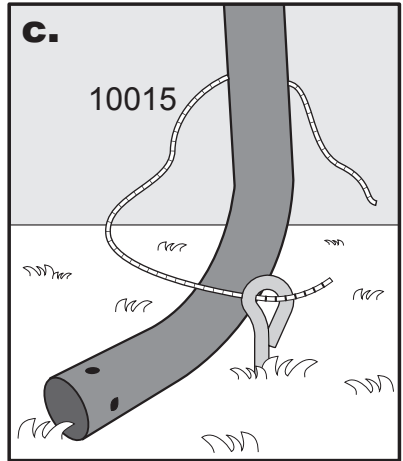
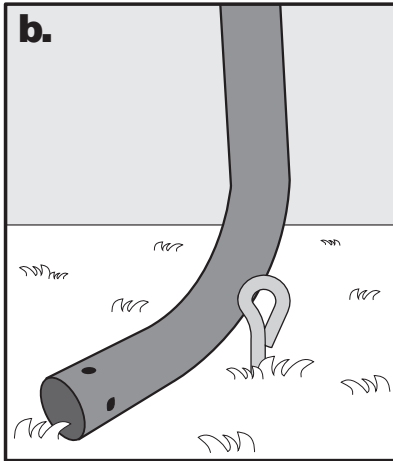
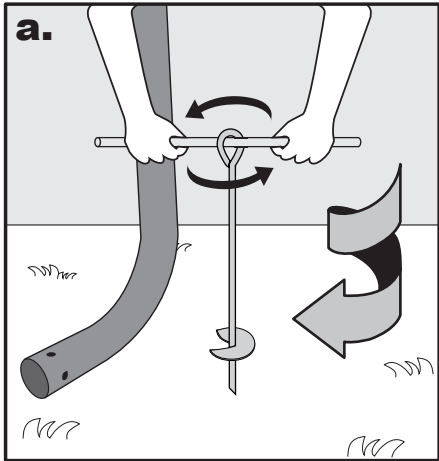
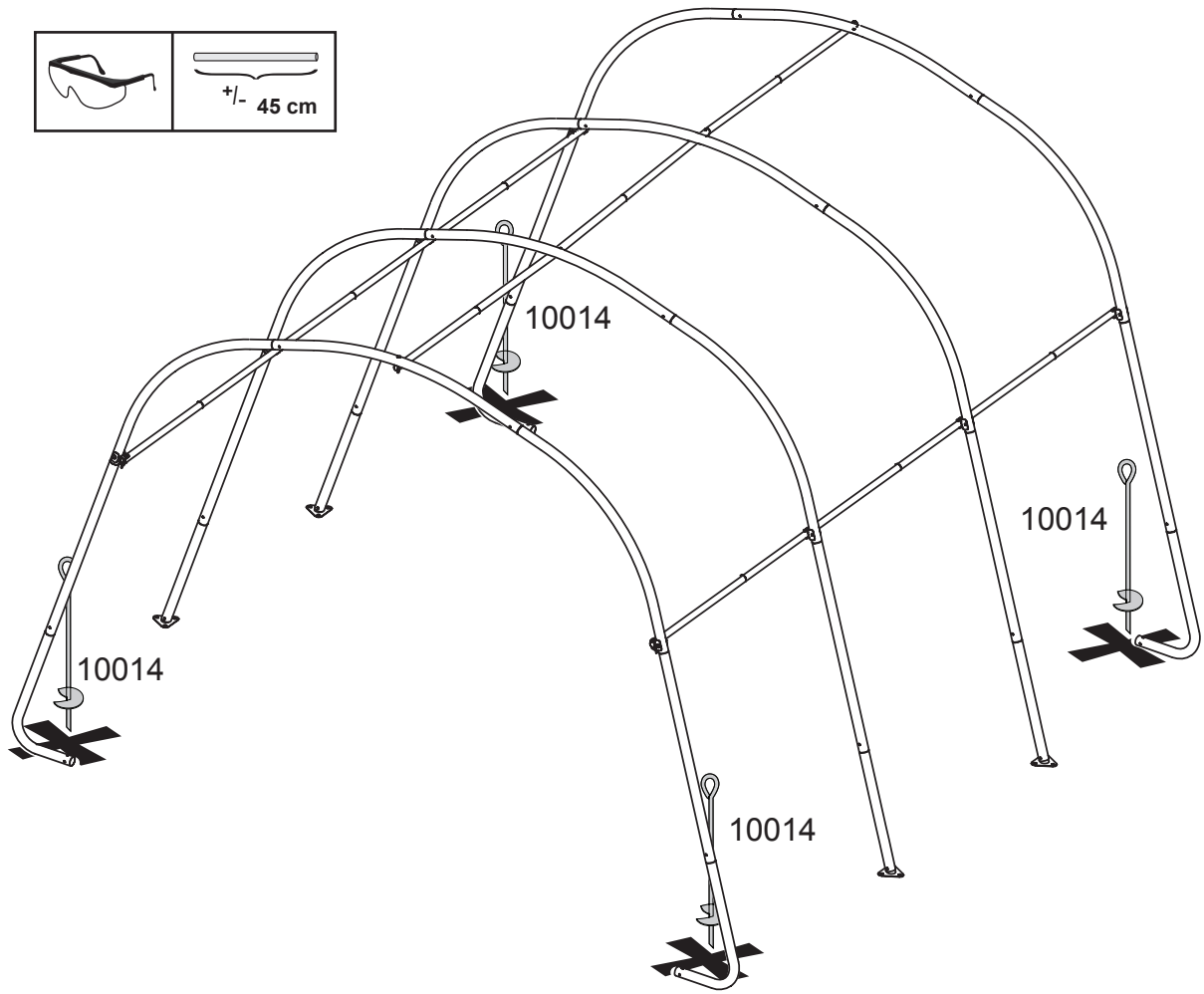
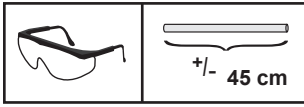

11.

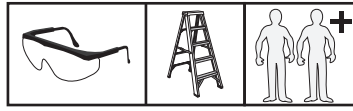

#62589: 806015
#62689: 803046

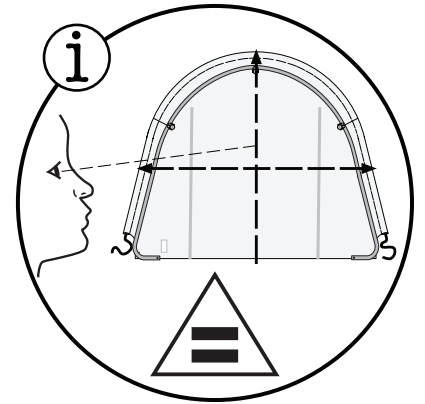
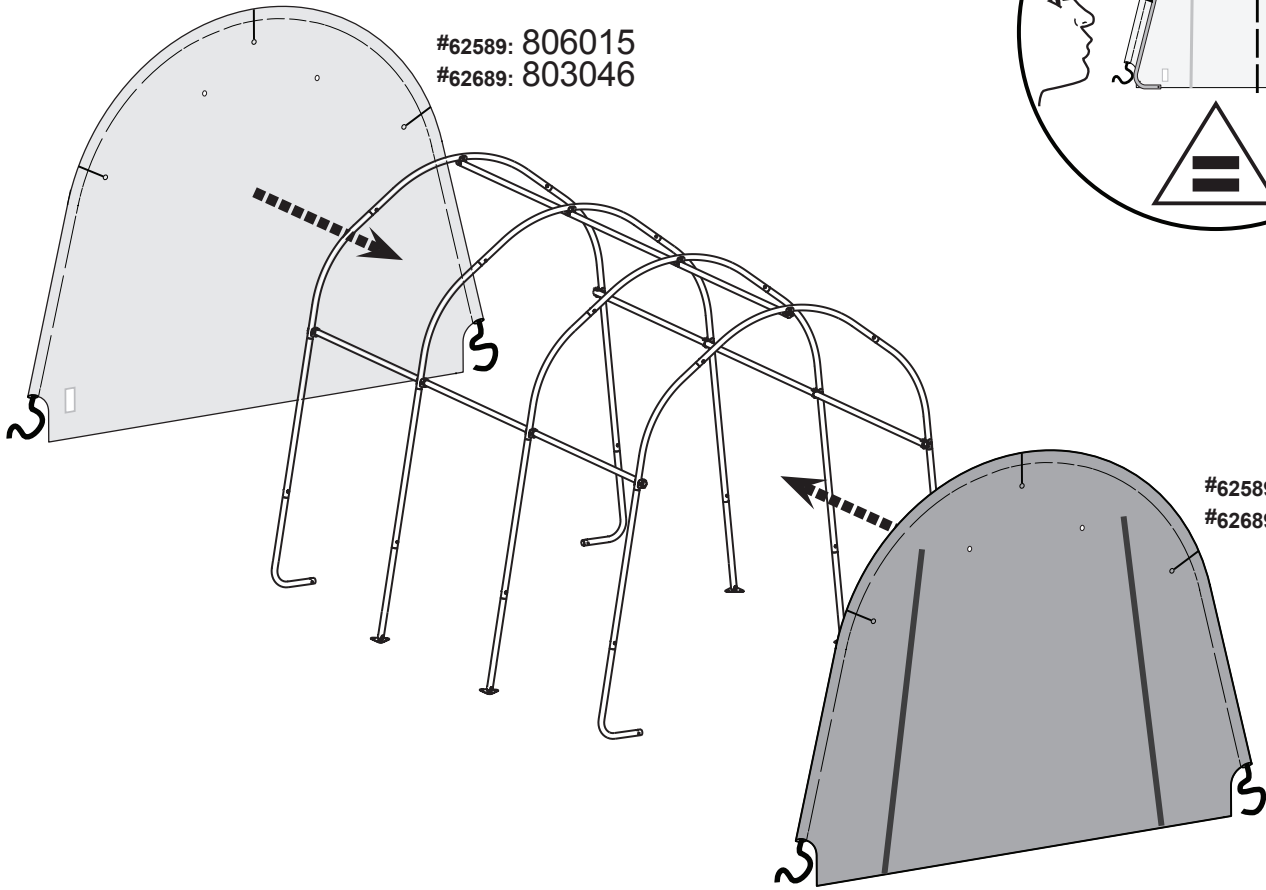

i

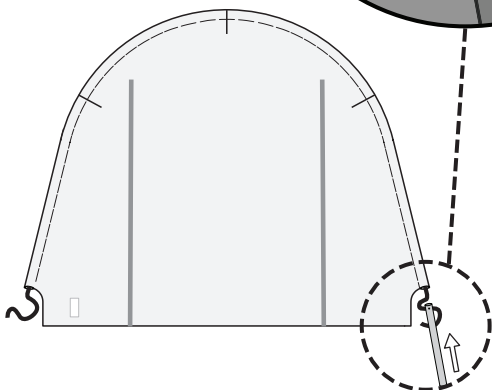
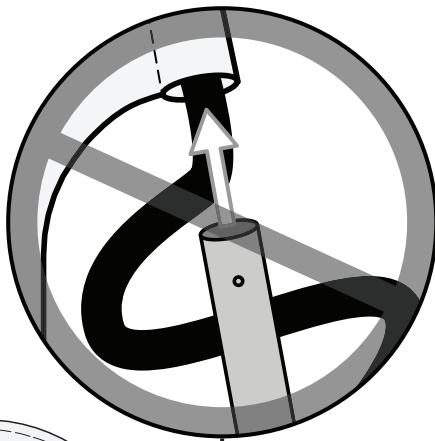

i

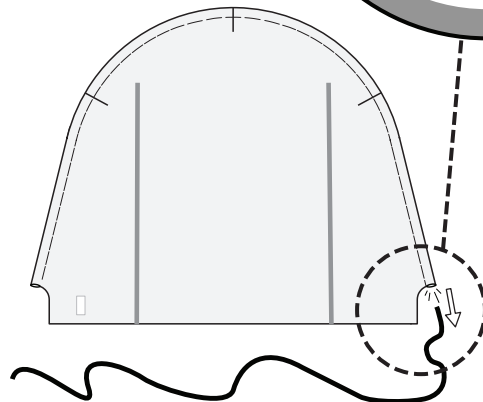
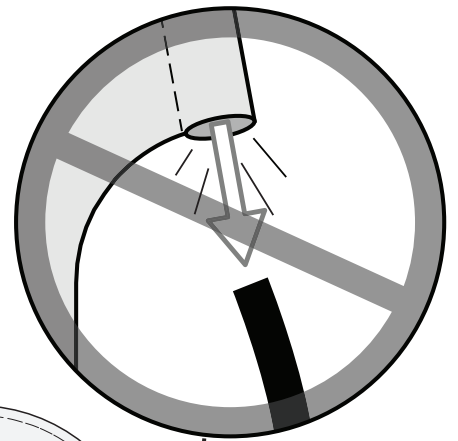

12.

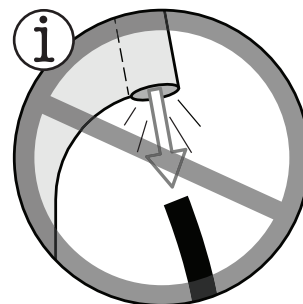
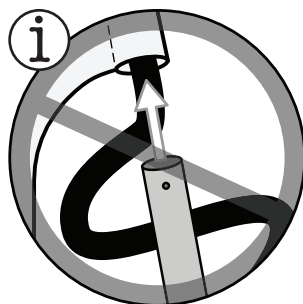
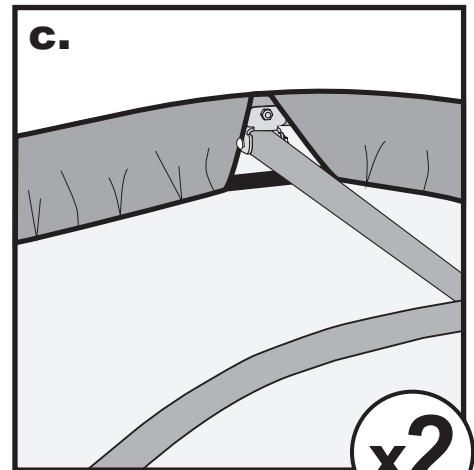
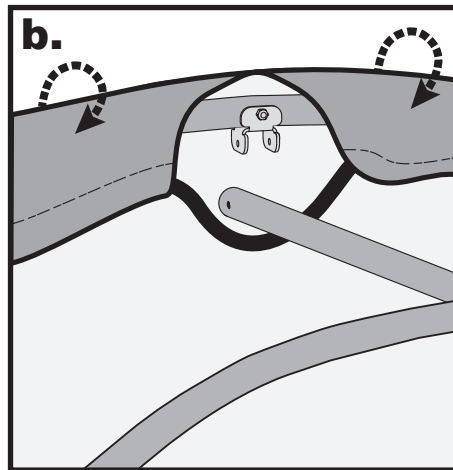
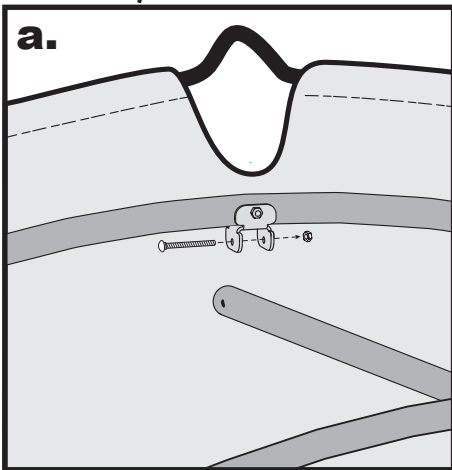
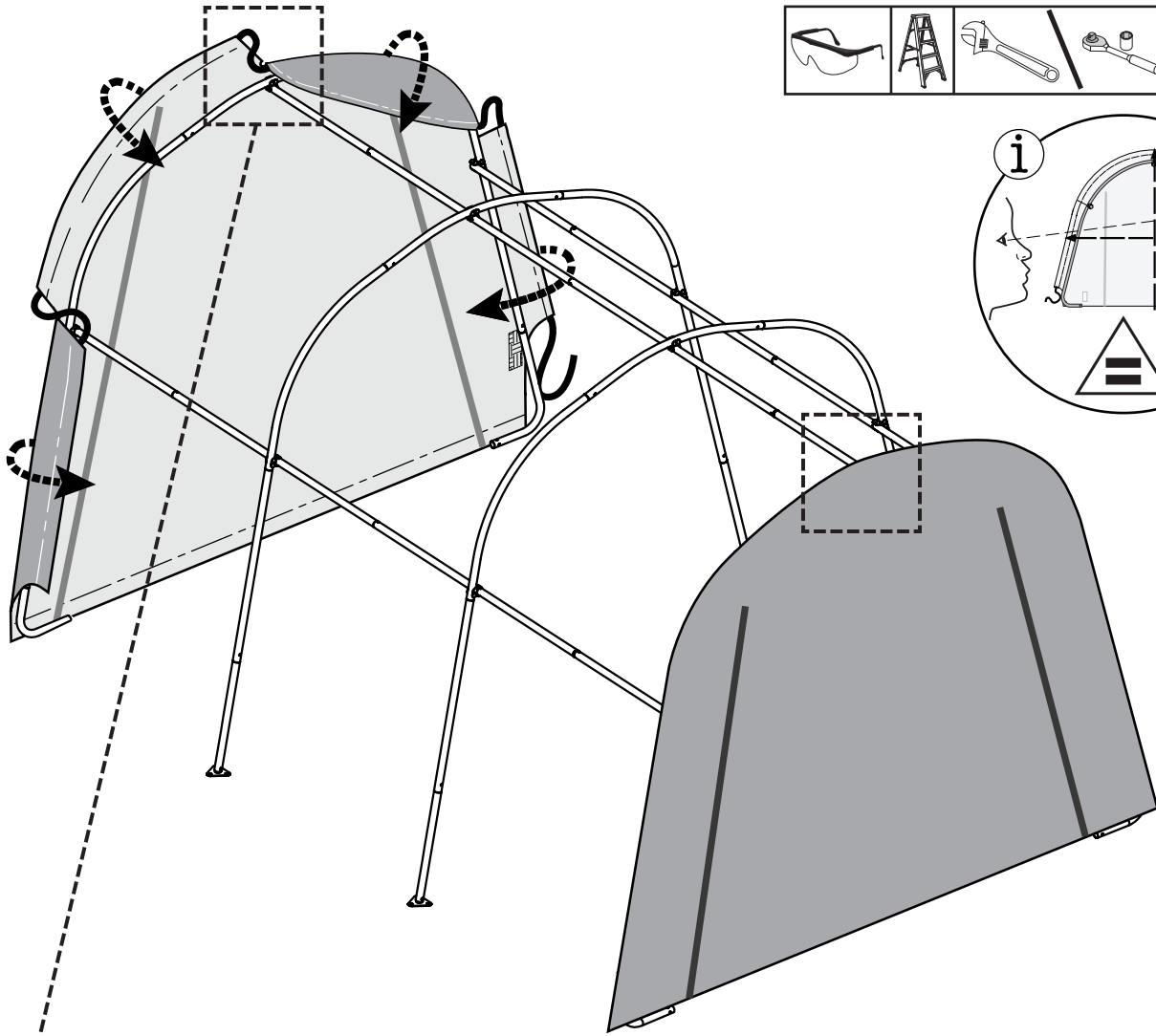
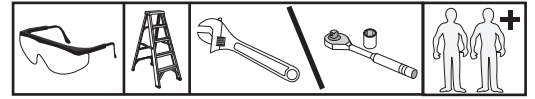

13.

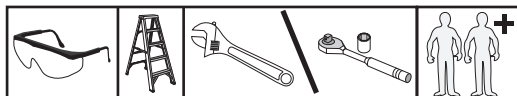
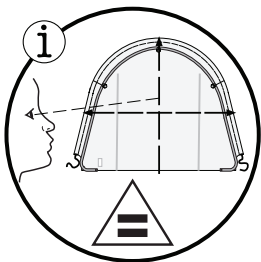

Tool-tighten all connections after the installation of end panels.

Serrez avec des outils toutes les connexions après l'installation de panneaux d'extrémité.

Herramienta a apretar todas las conexiones después de instalar paneles de los extremos.

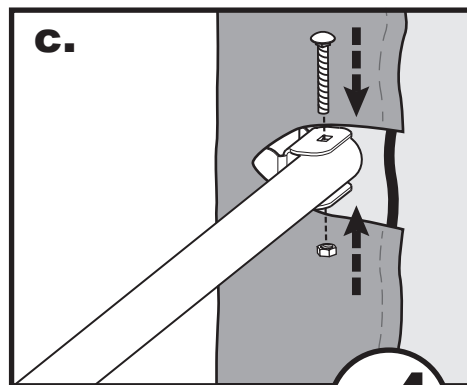
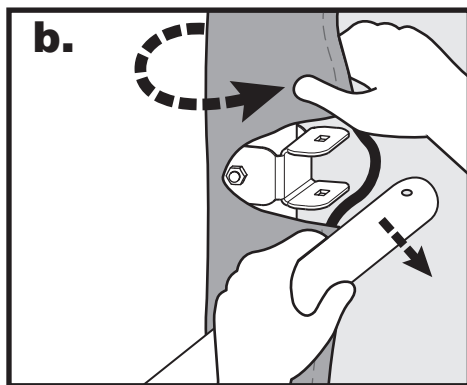
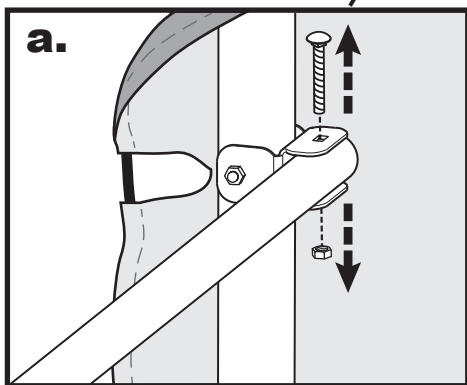
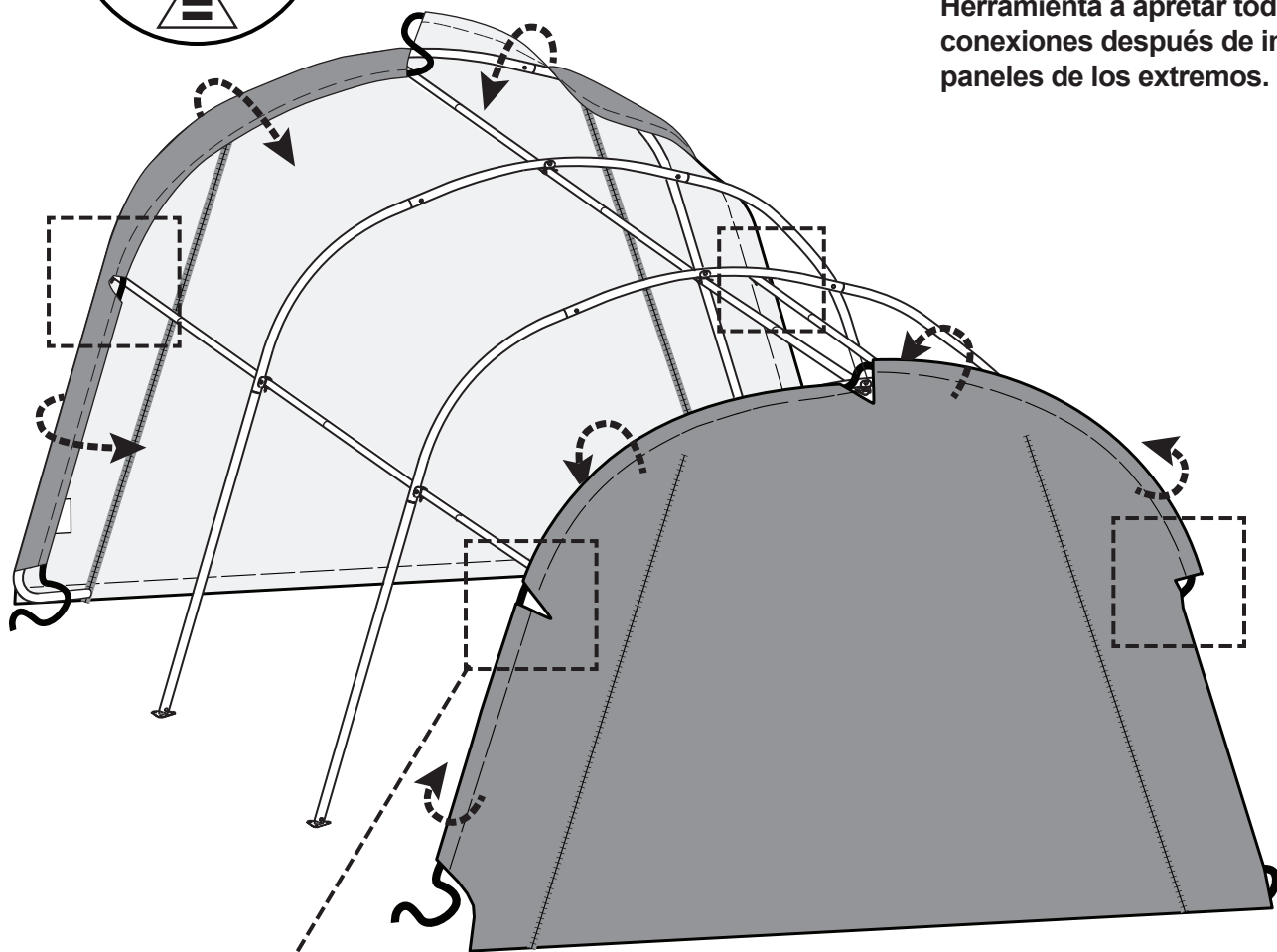

x4

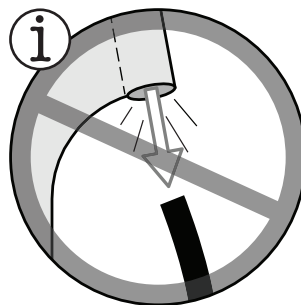
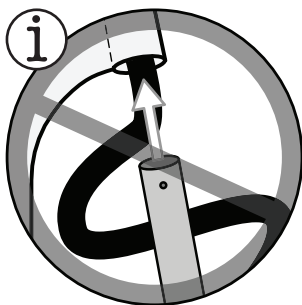

14.a.

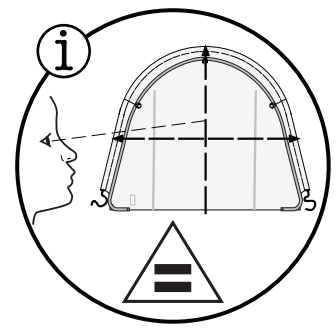
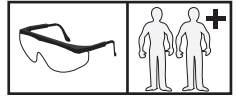
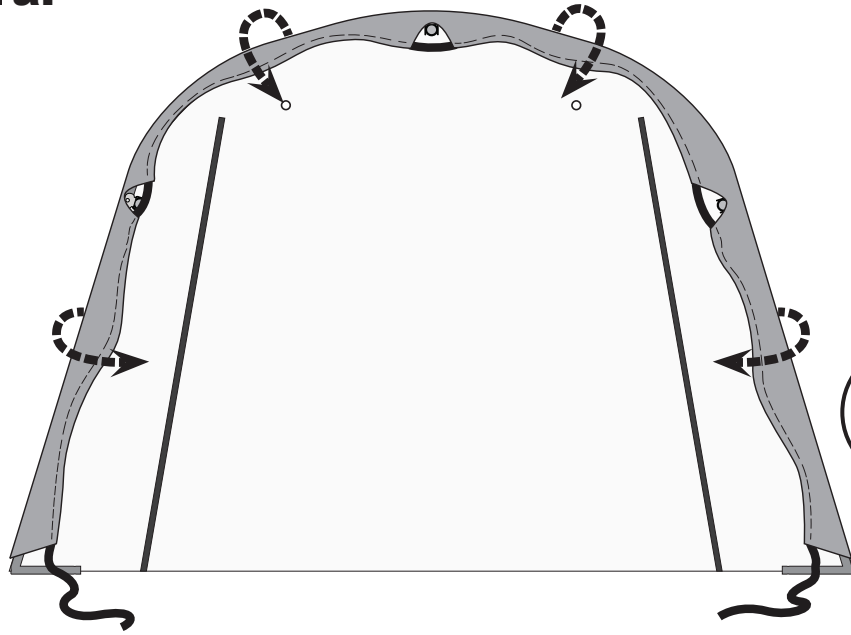

x2

b.

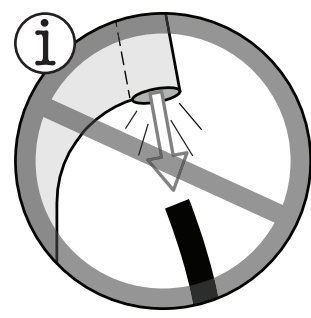
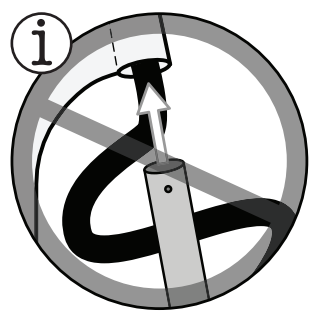
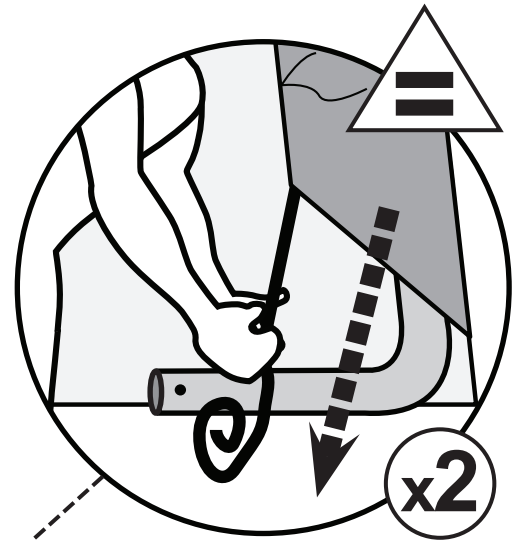
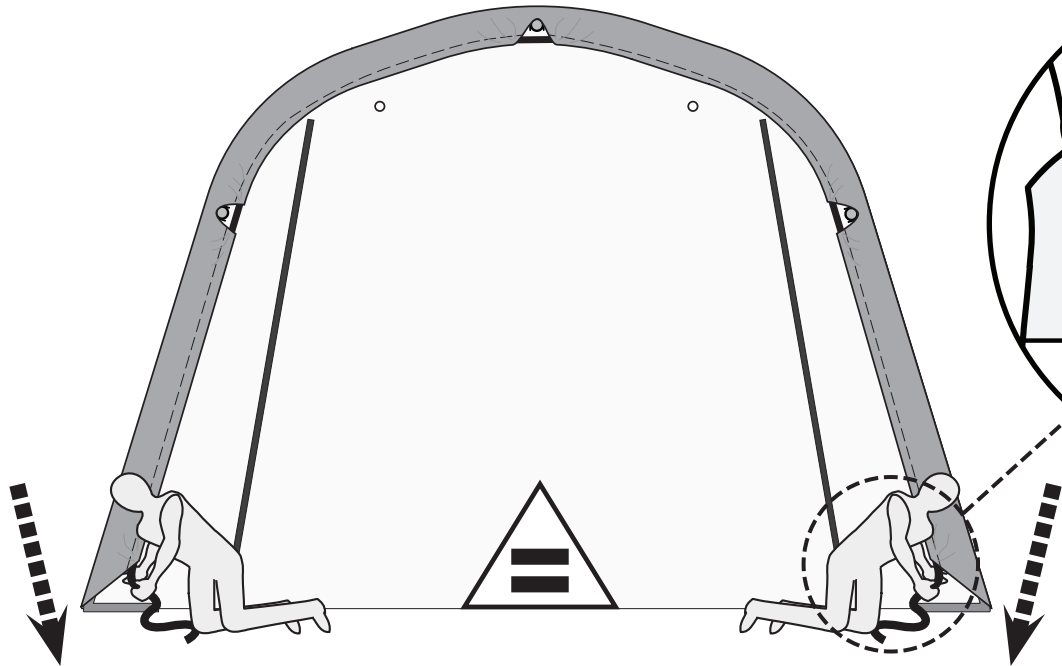

15.

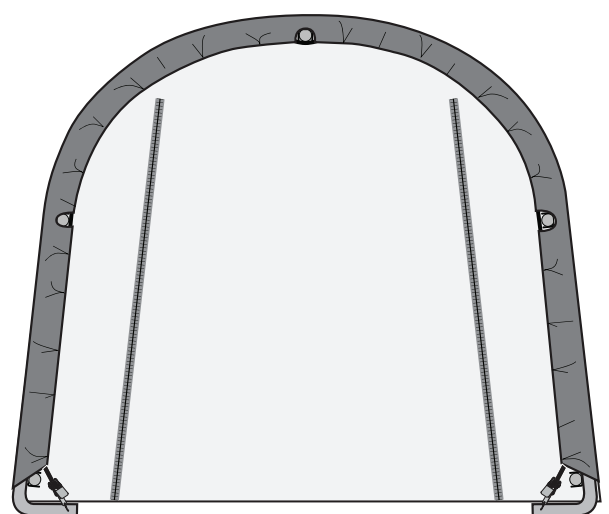
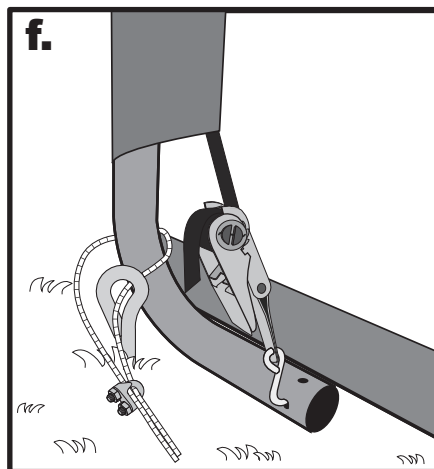
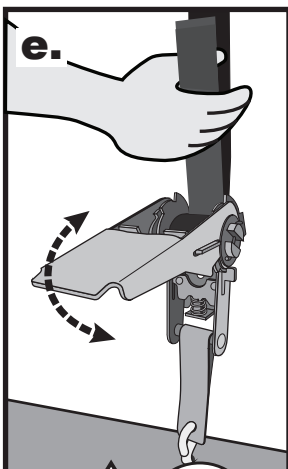
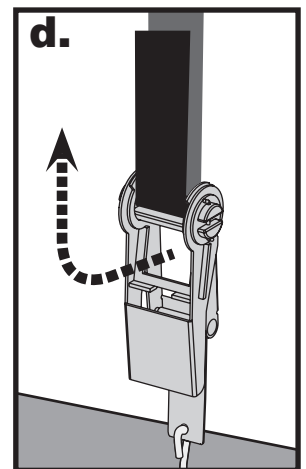
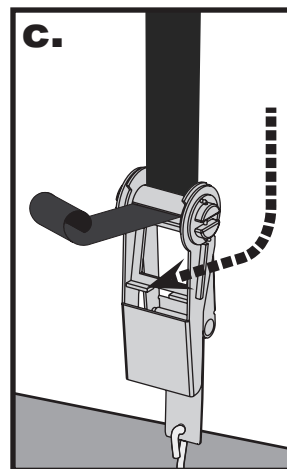
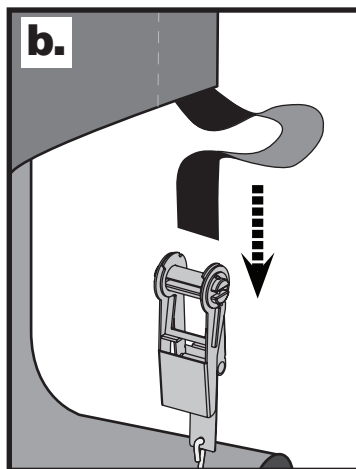
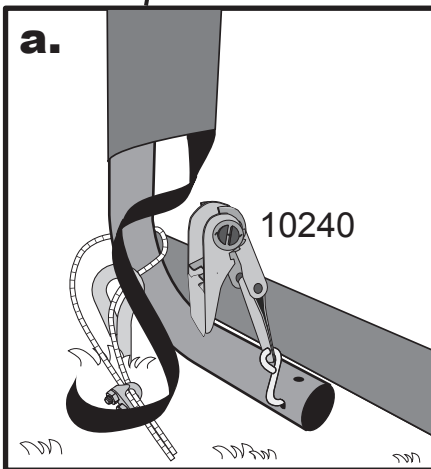
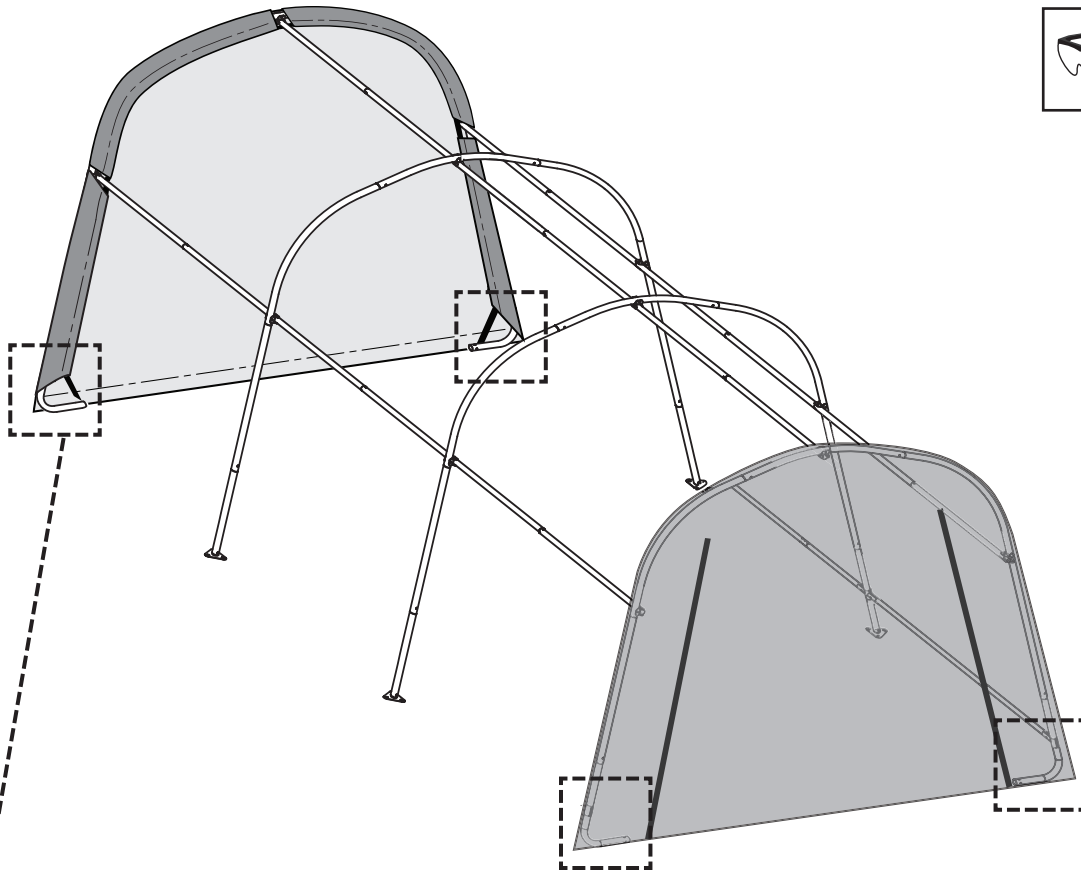

16.



a.

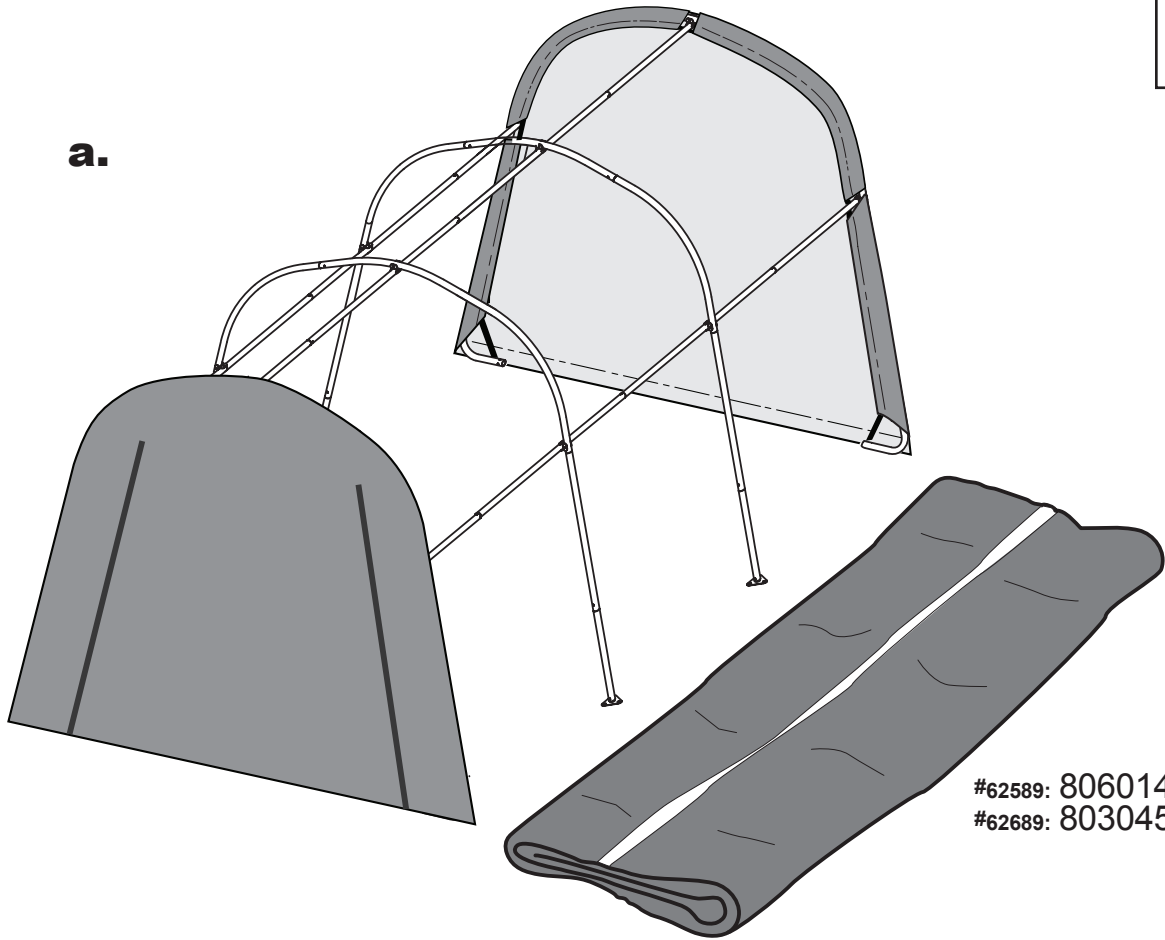

#62589: 806014
#62689: 803045

b.

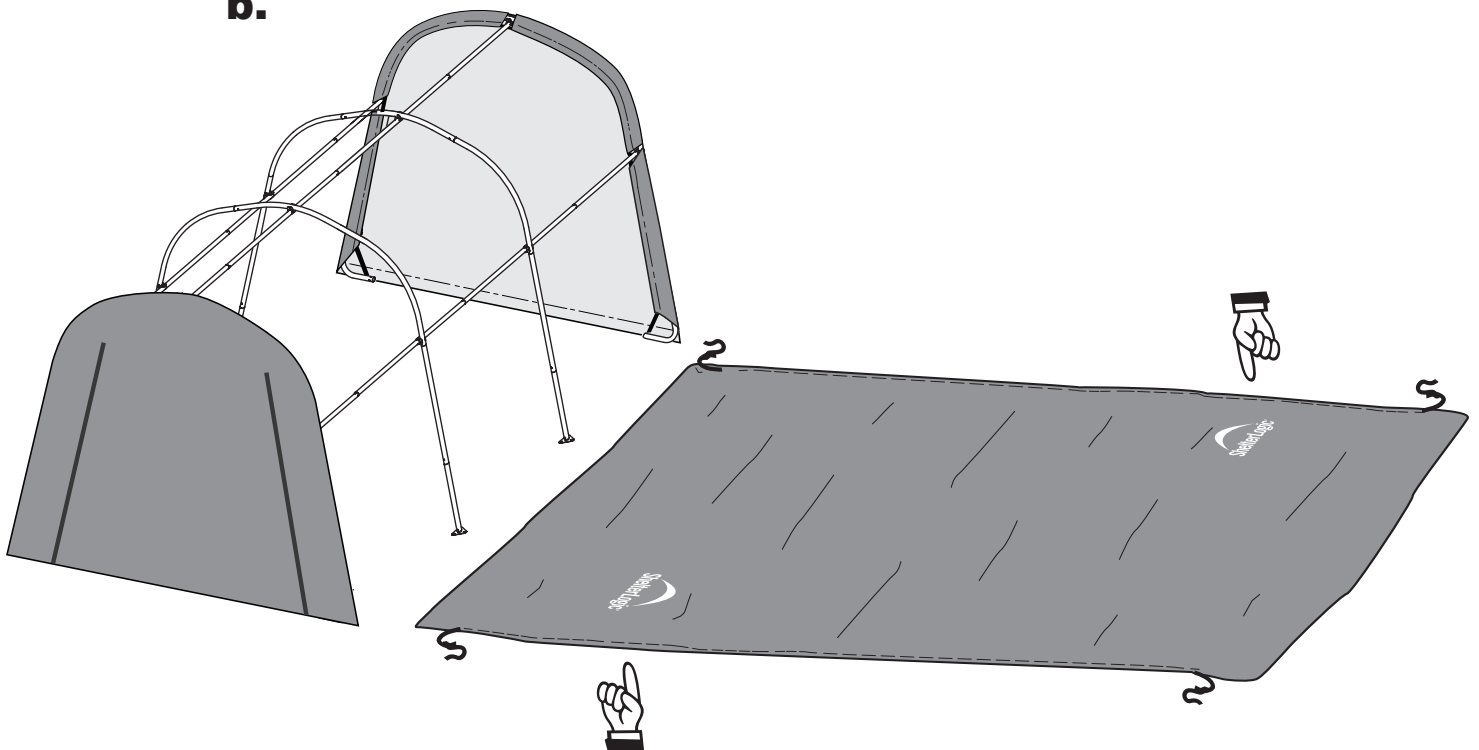

17.

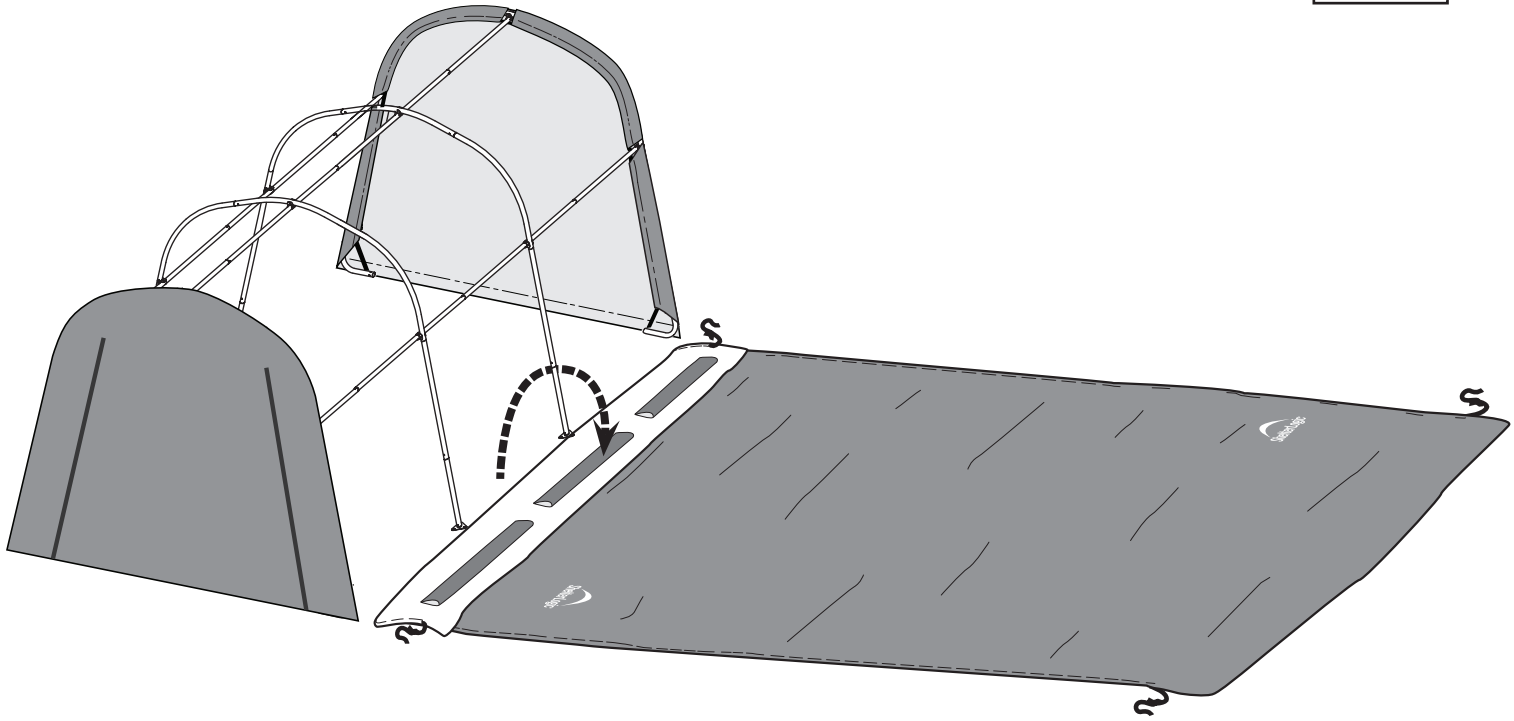

18.

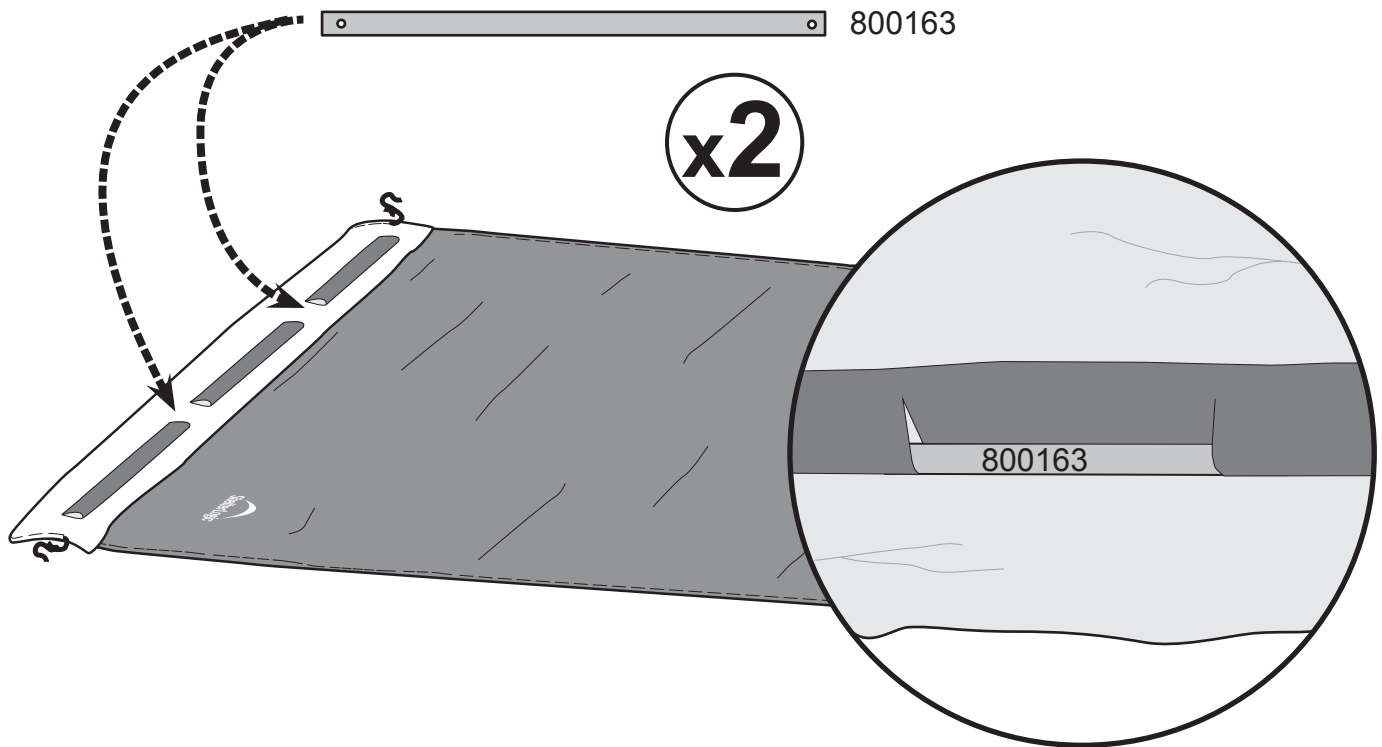

19.



#62589: 806014
#62689: 803045

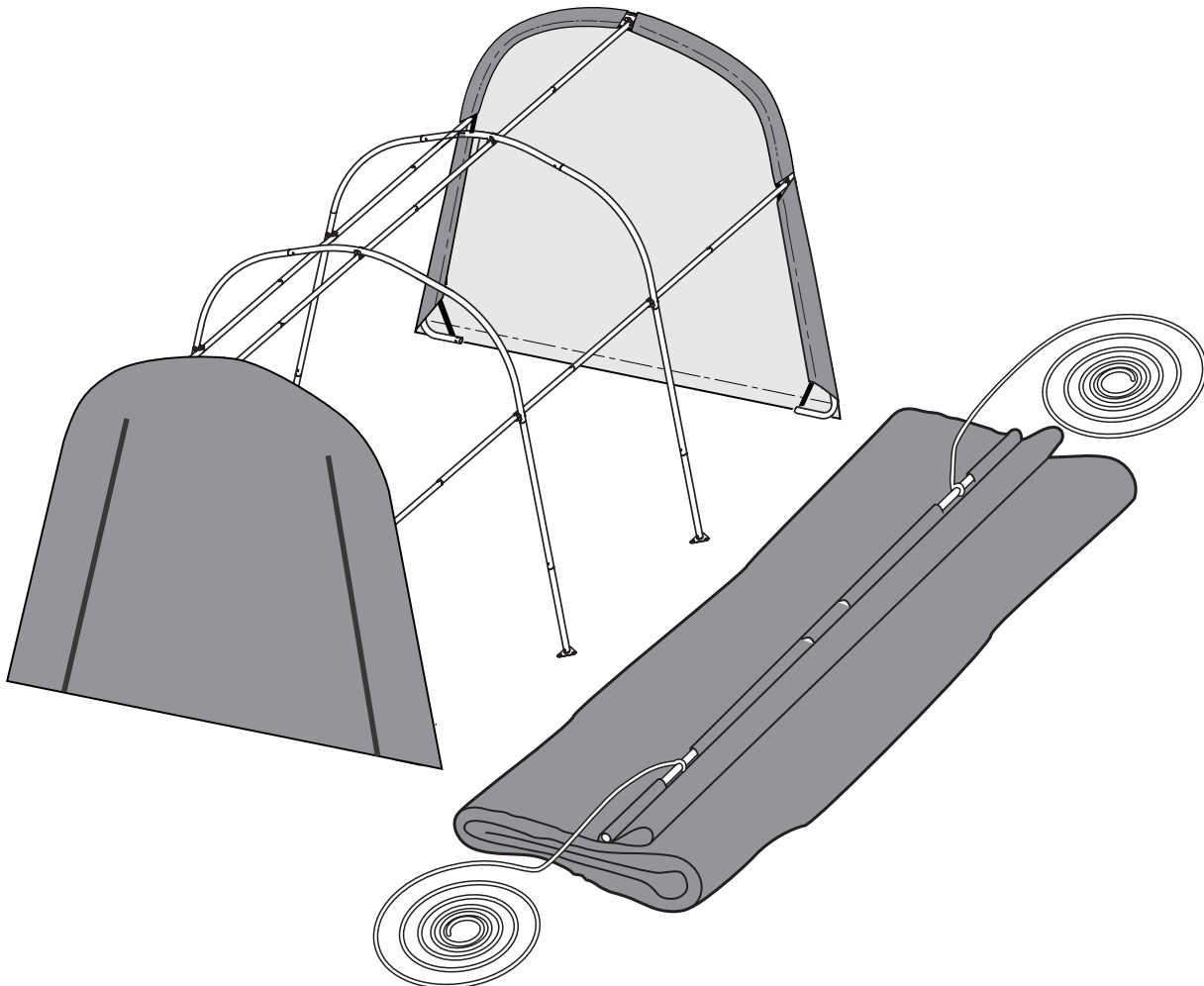
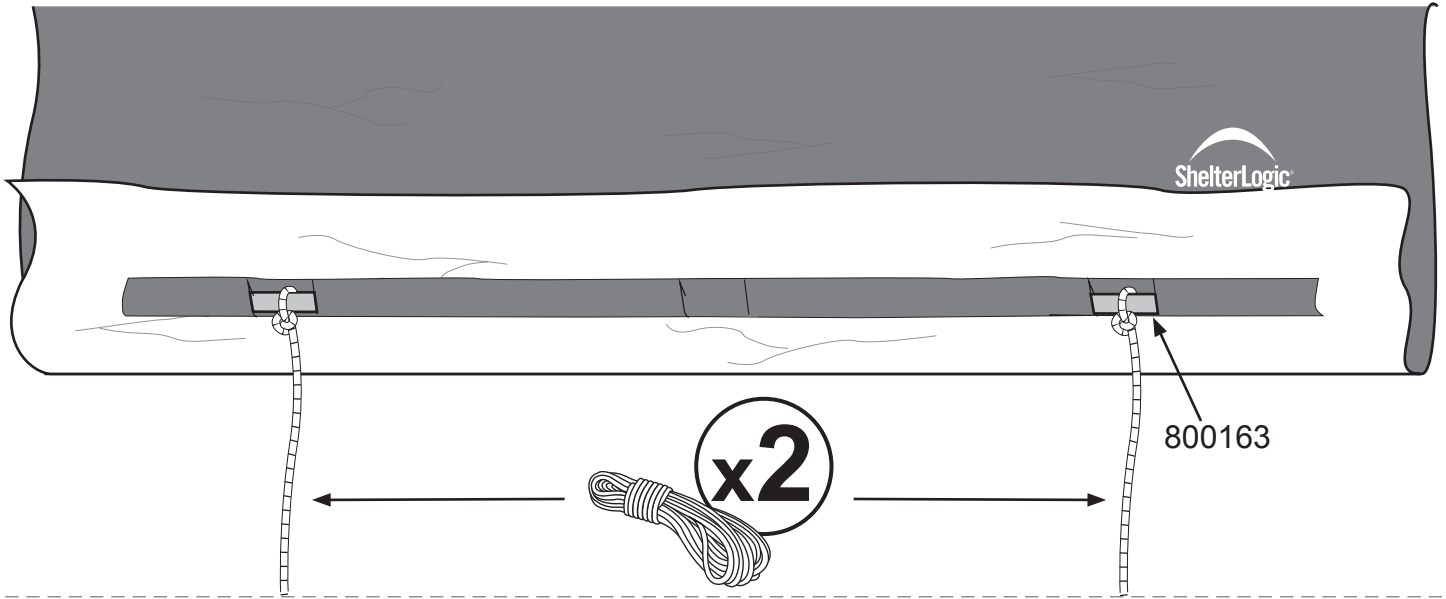

20.a.

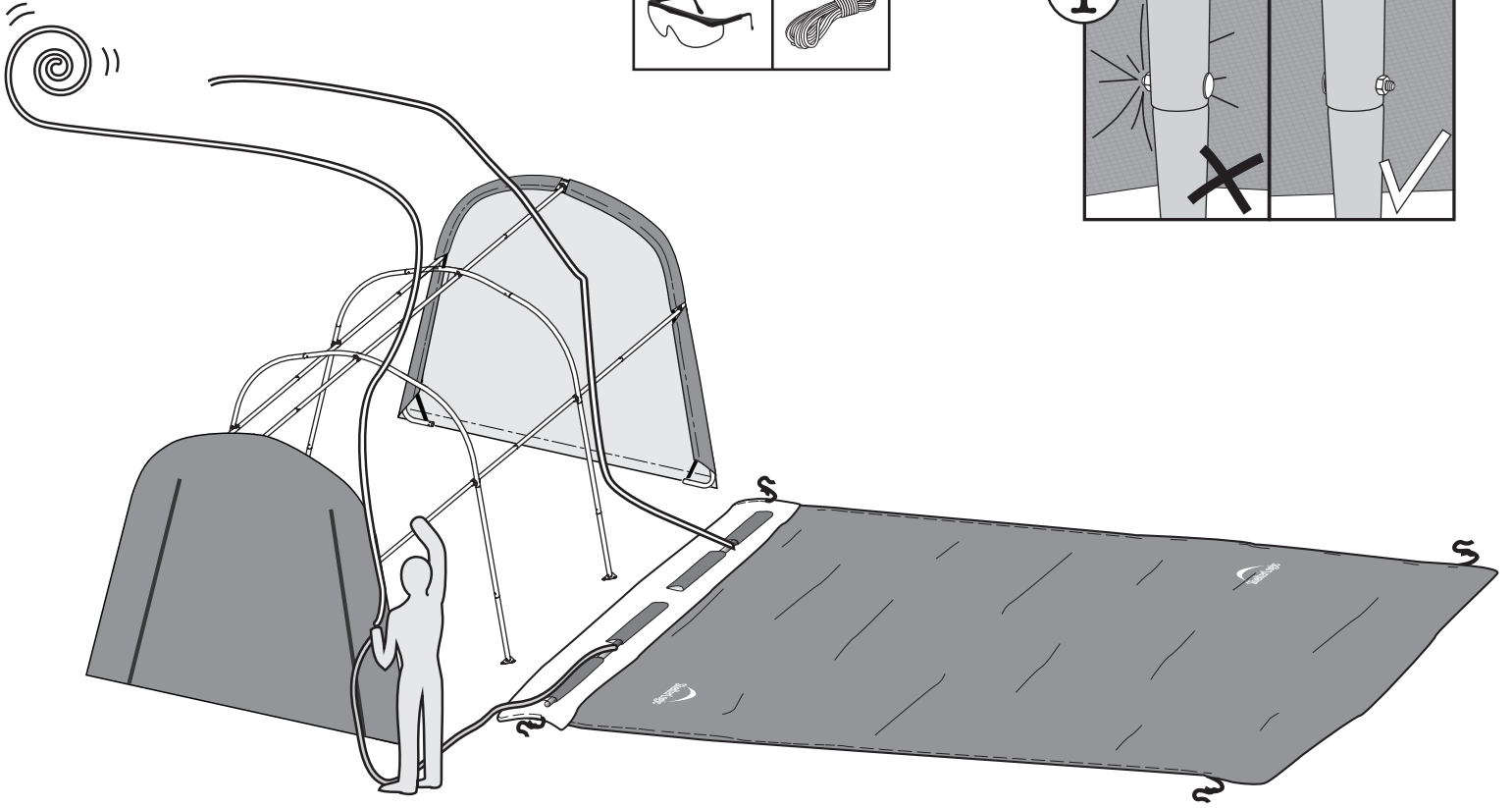

b.

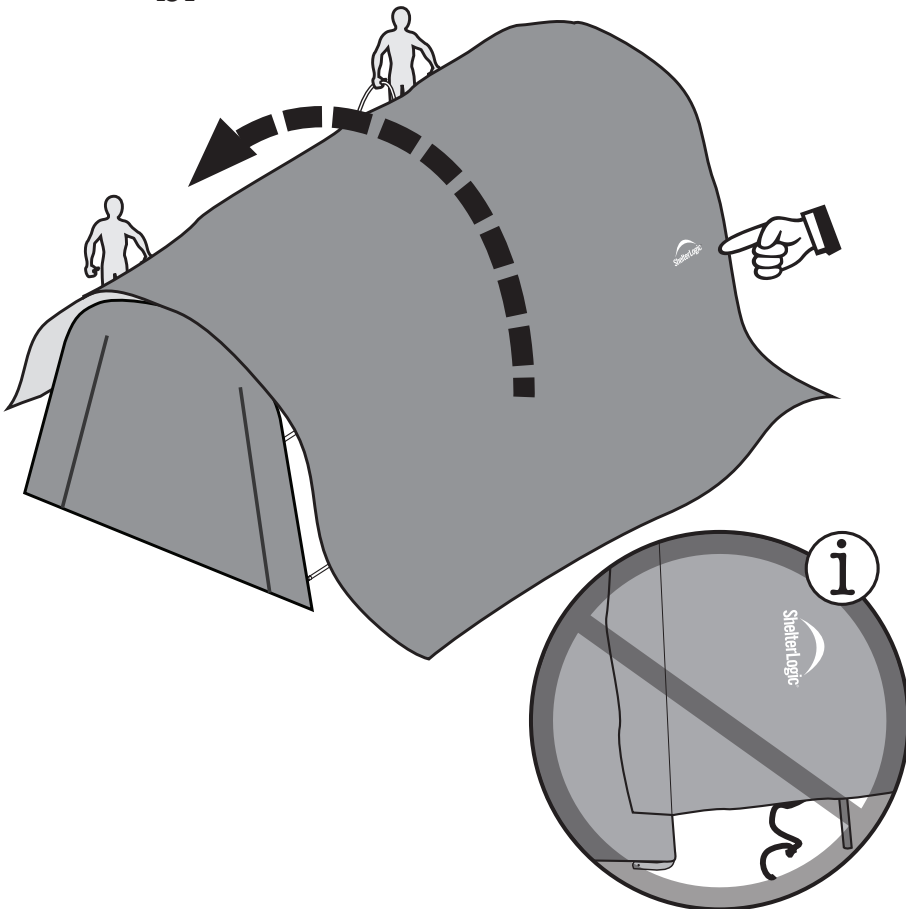

c.

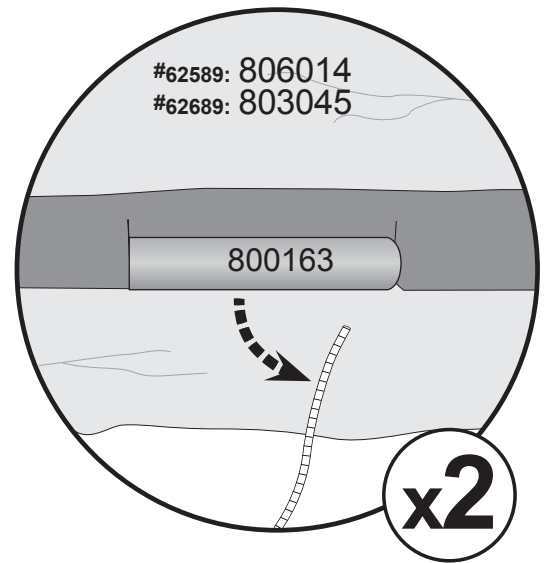

21.

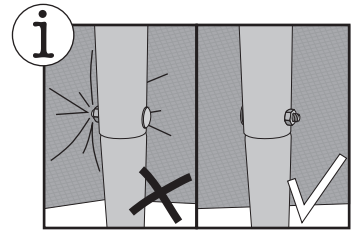
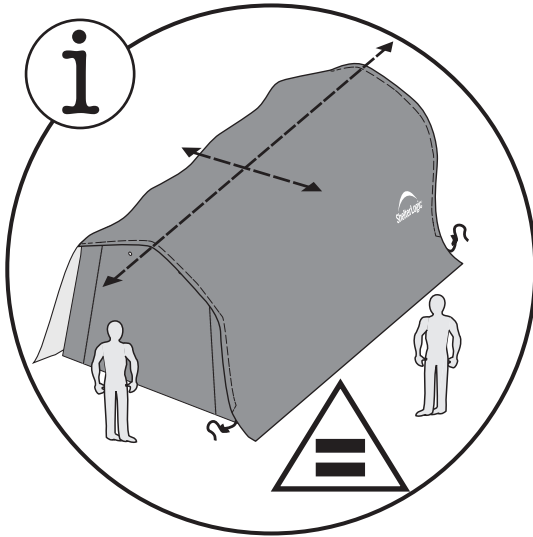

a.

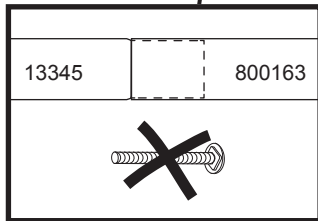
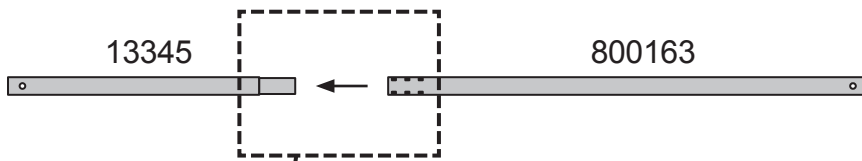

x6

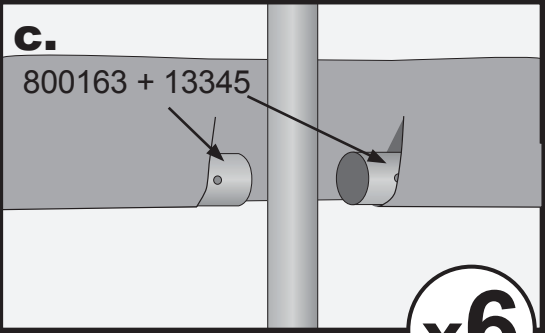
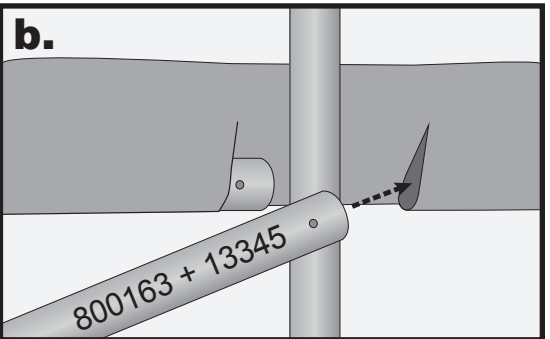

x6

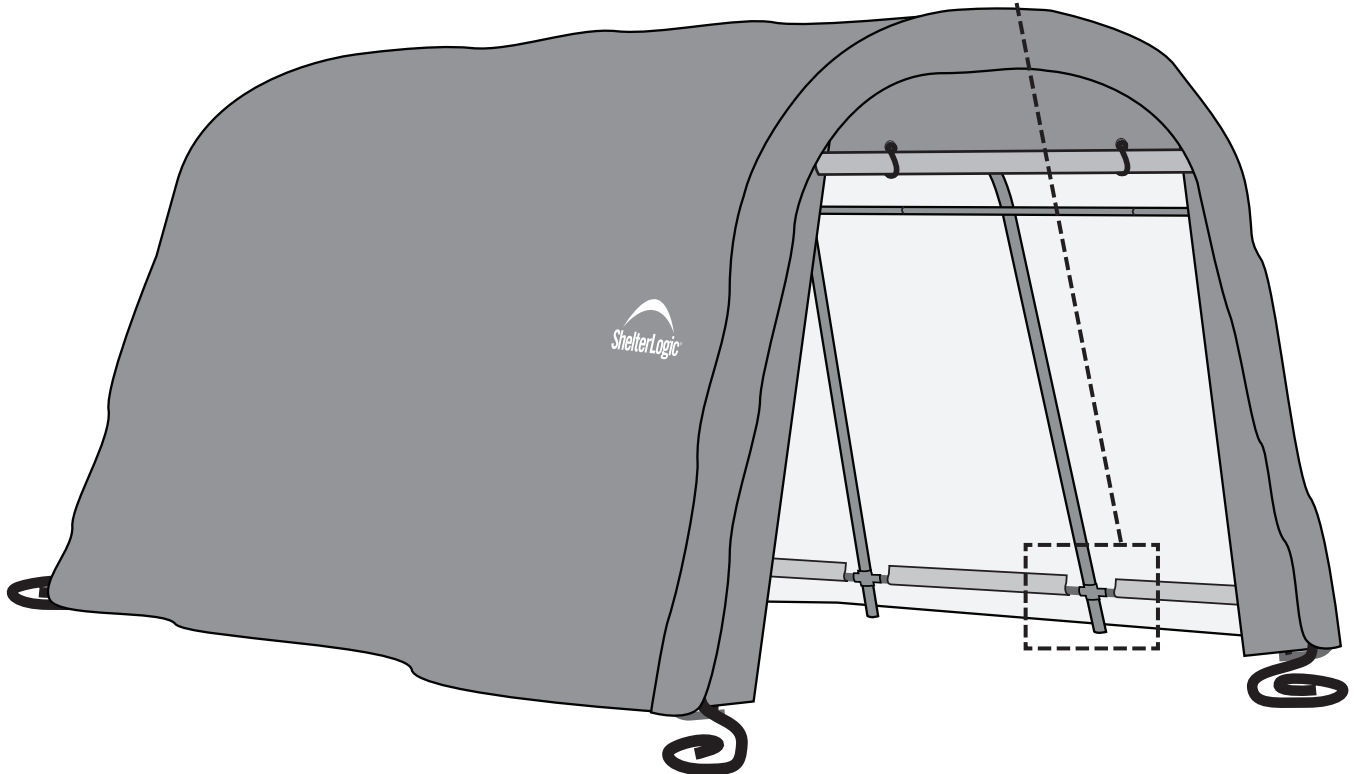

22.

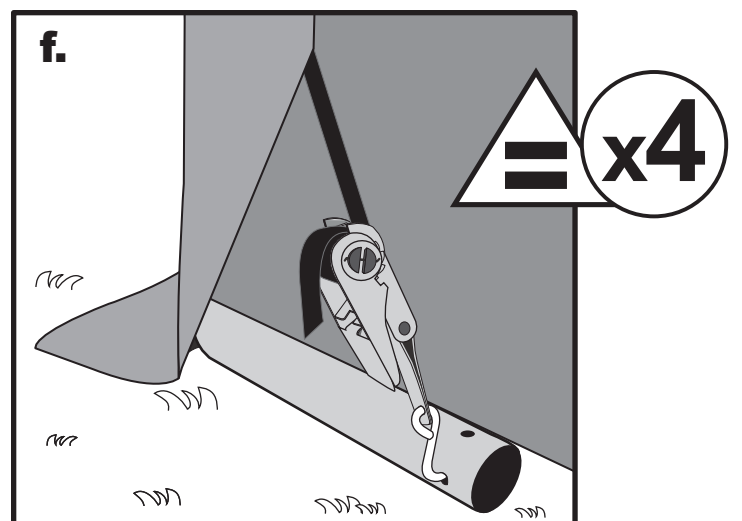
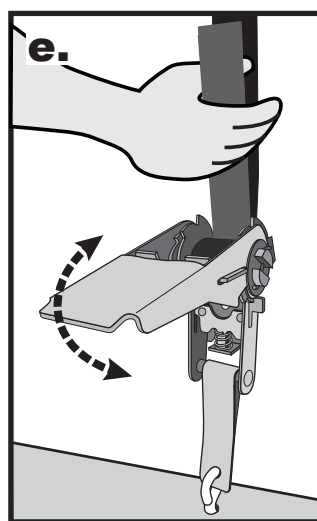
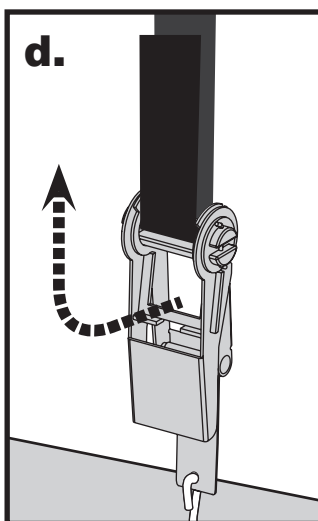
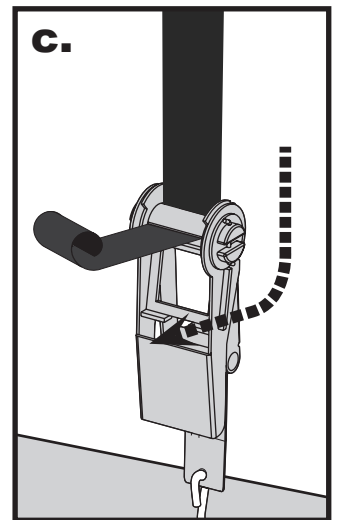
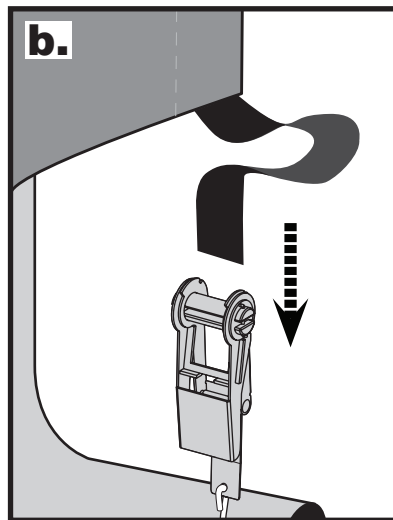
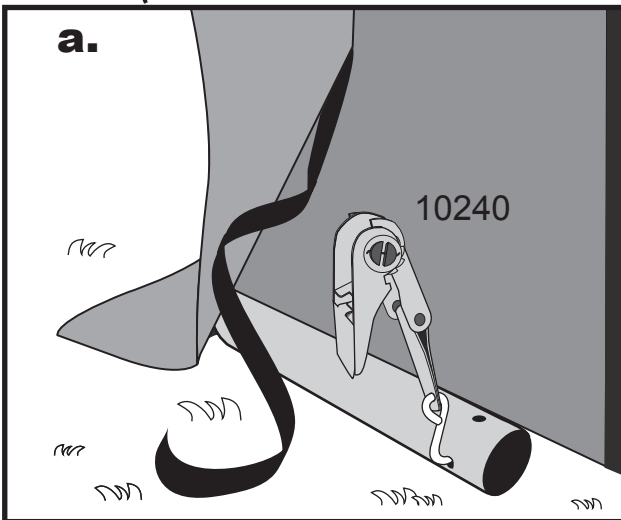
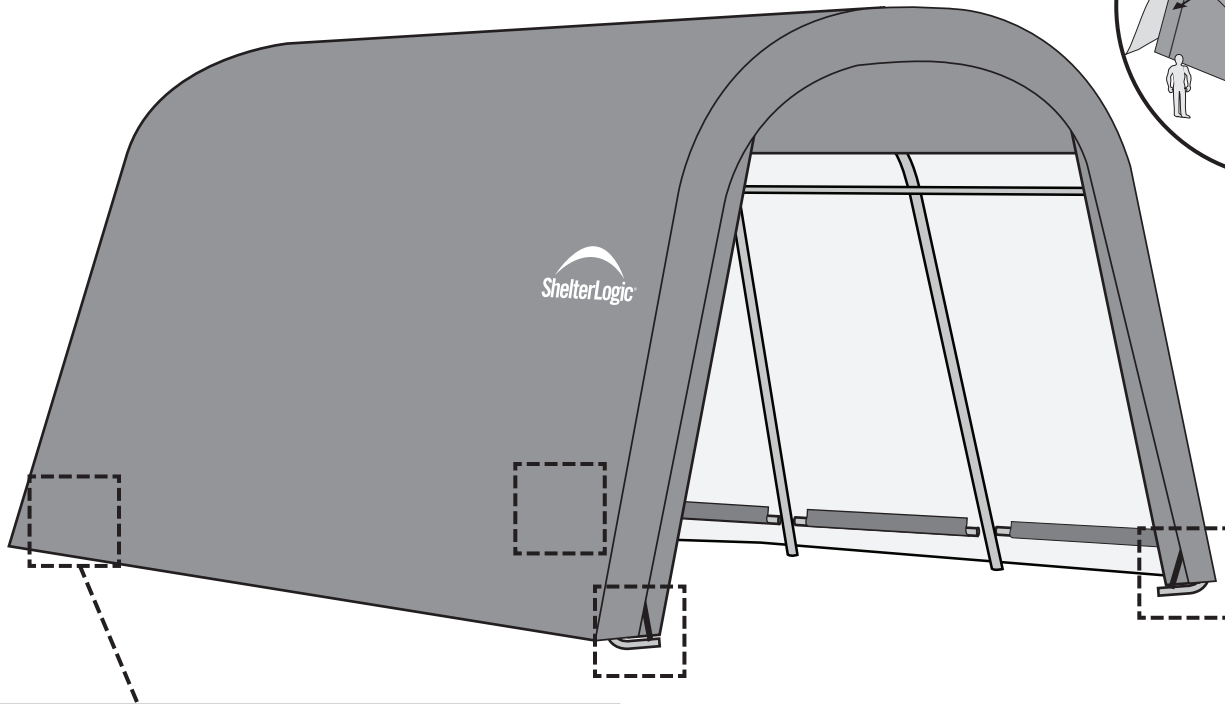
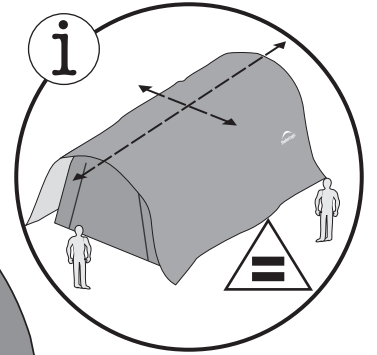
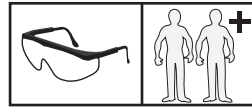

23.

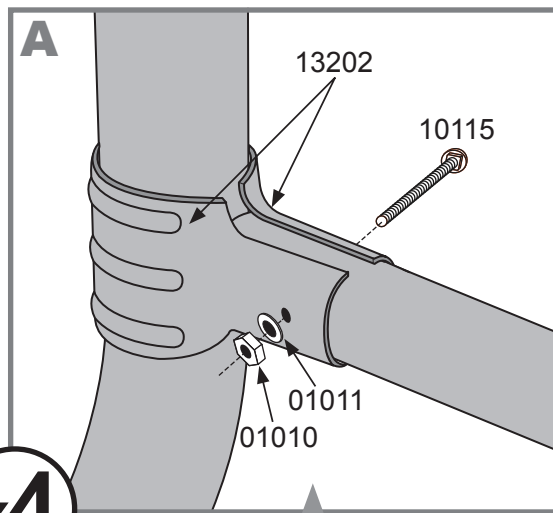
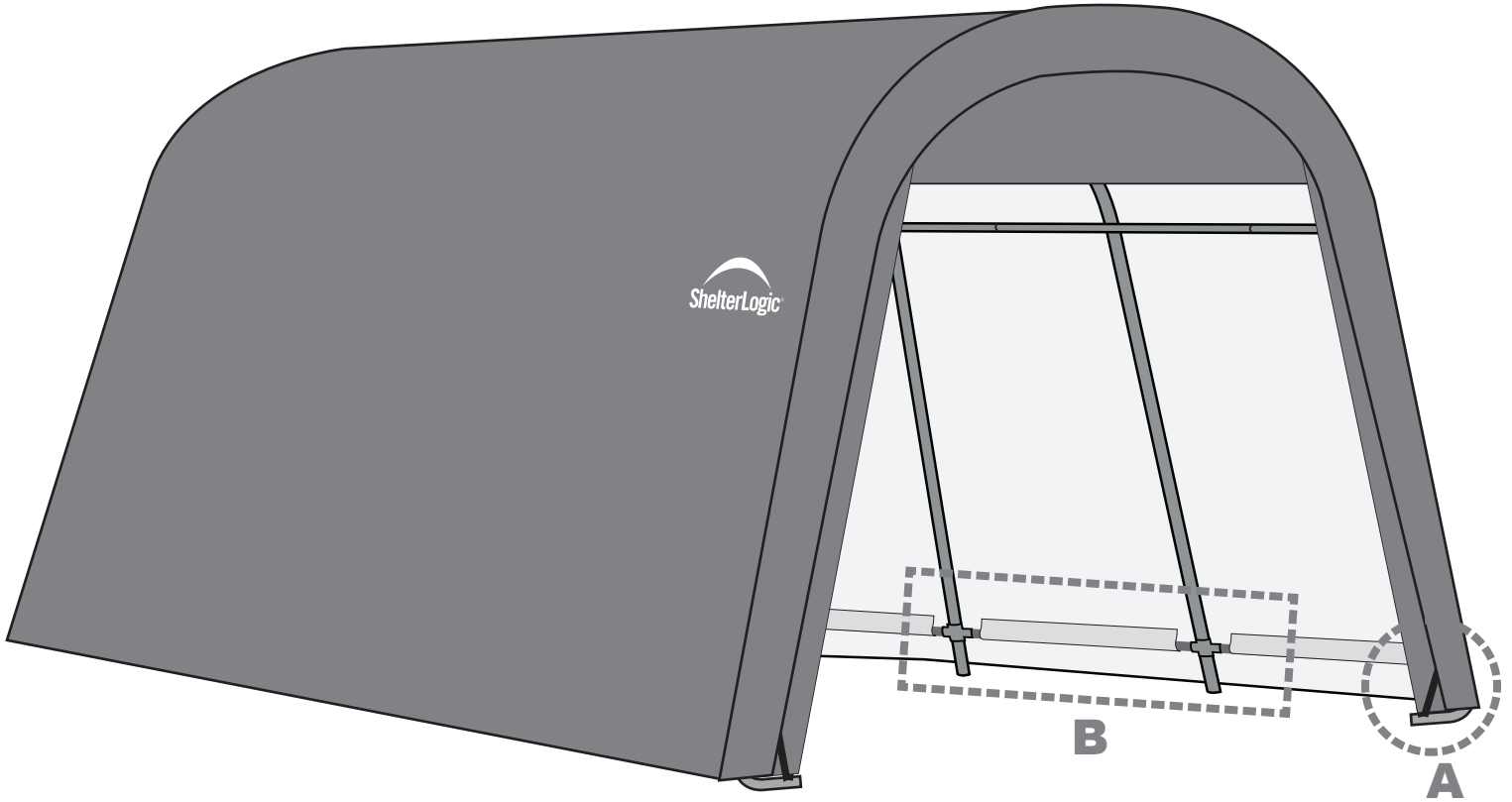
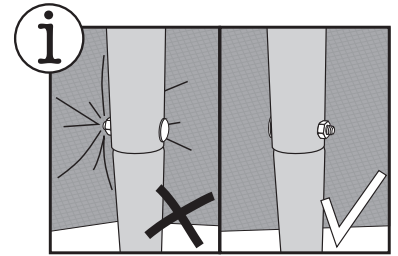
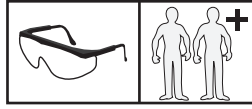

x4

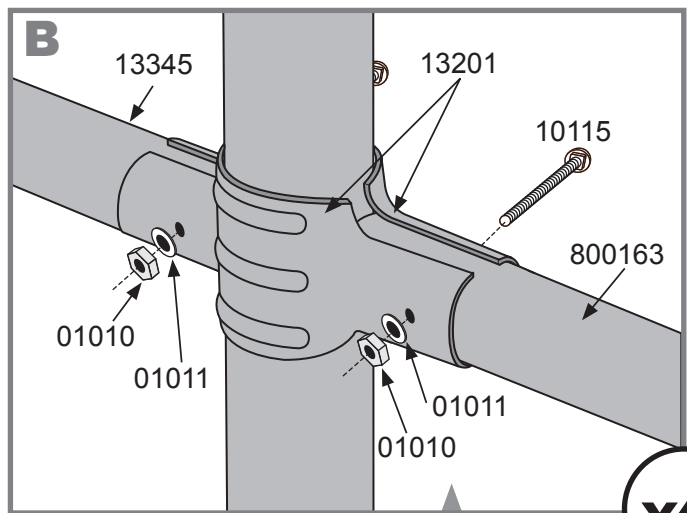

x4

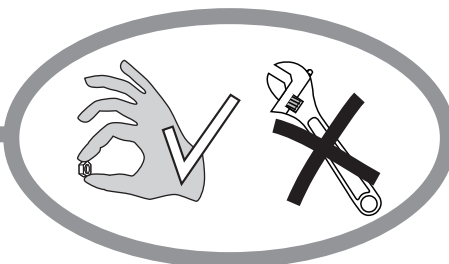

24.

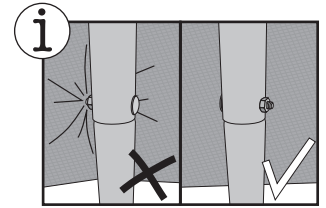
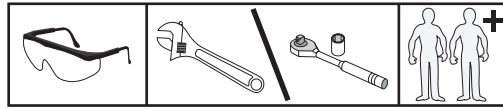

To ensure longer cover life, check and retighten the cover every month.

Pour prolonger la durée utile de la toile, vérifiez son serrage chaque mois.

Para asegurar una larga vida de la cubierta, revise y vuelva a apretar la cubierta cada mes.

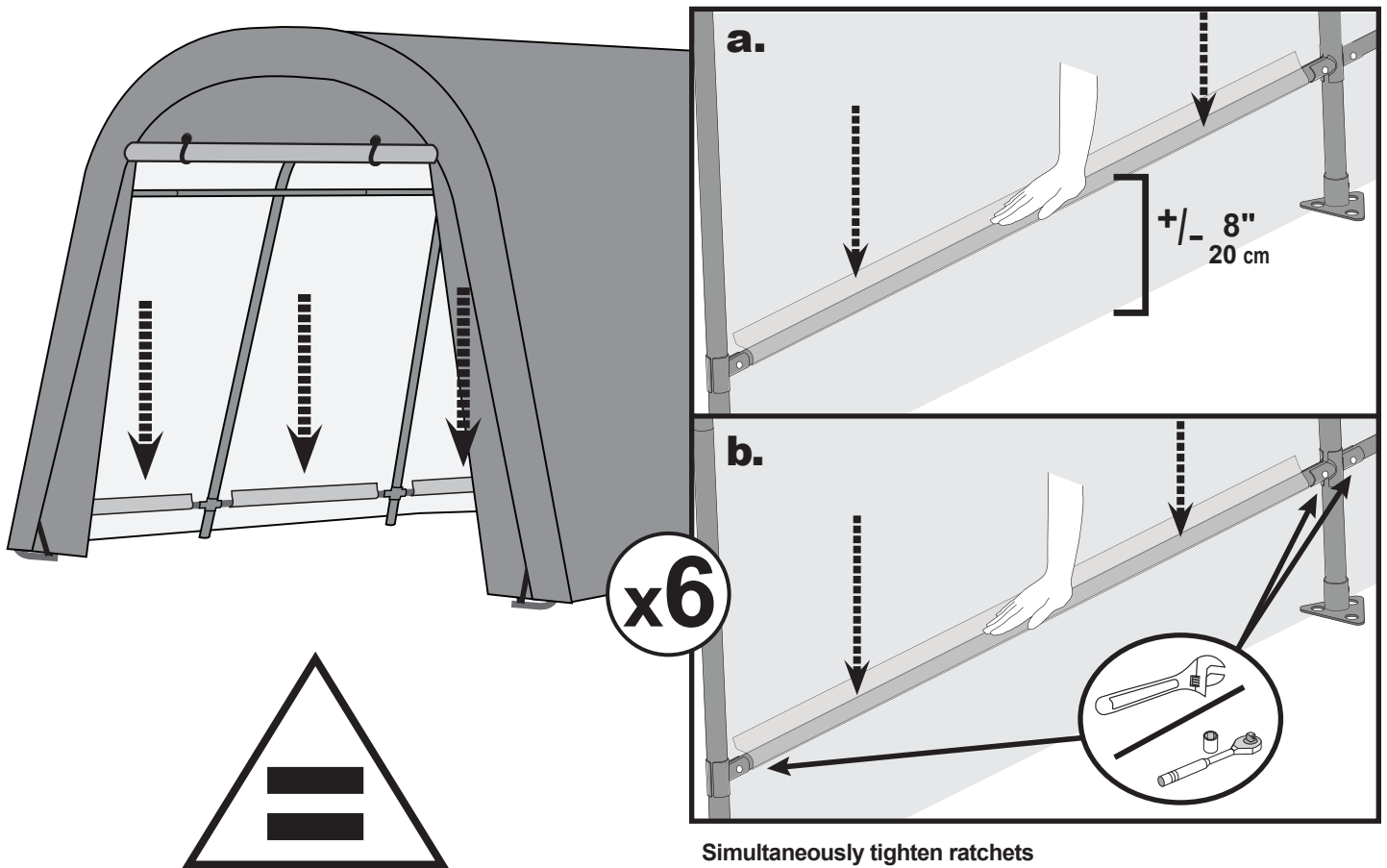

Simultaneously tighten ratchets A & B, then C & D.

Serrez simultanément les cliquets A et B, puis C et D.

Al mismo tiempo apretar trinquetes A y B, después C y D.

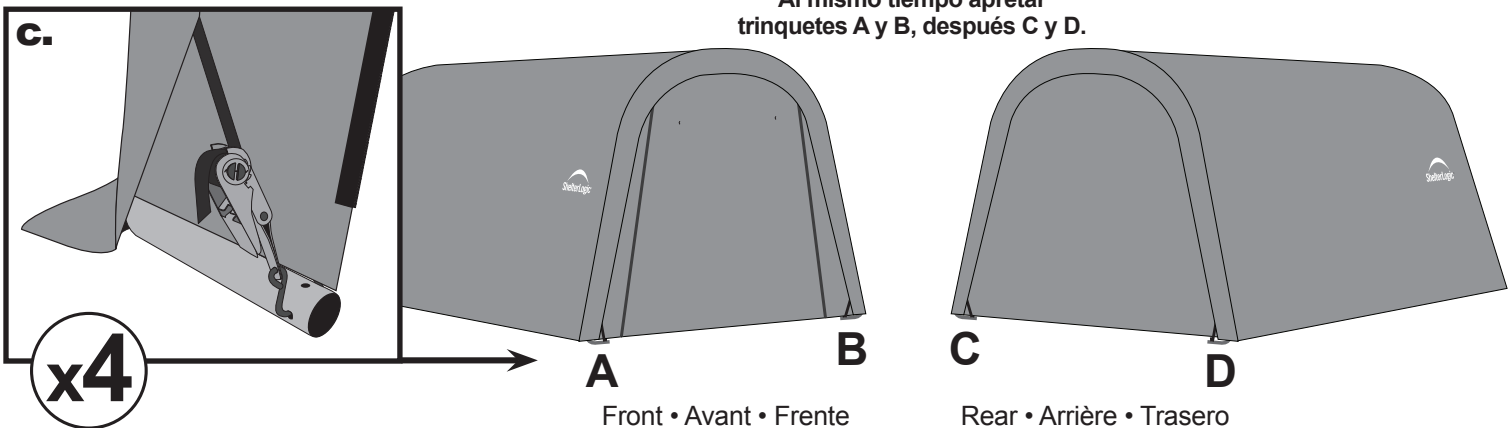

25.



a.

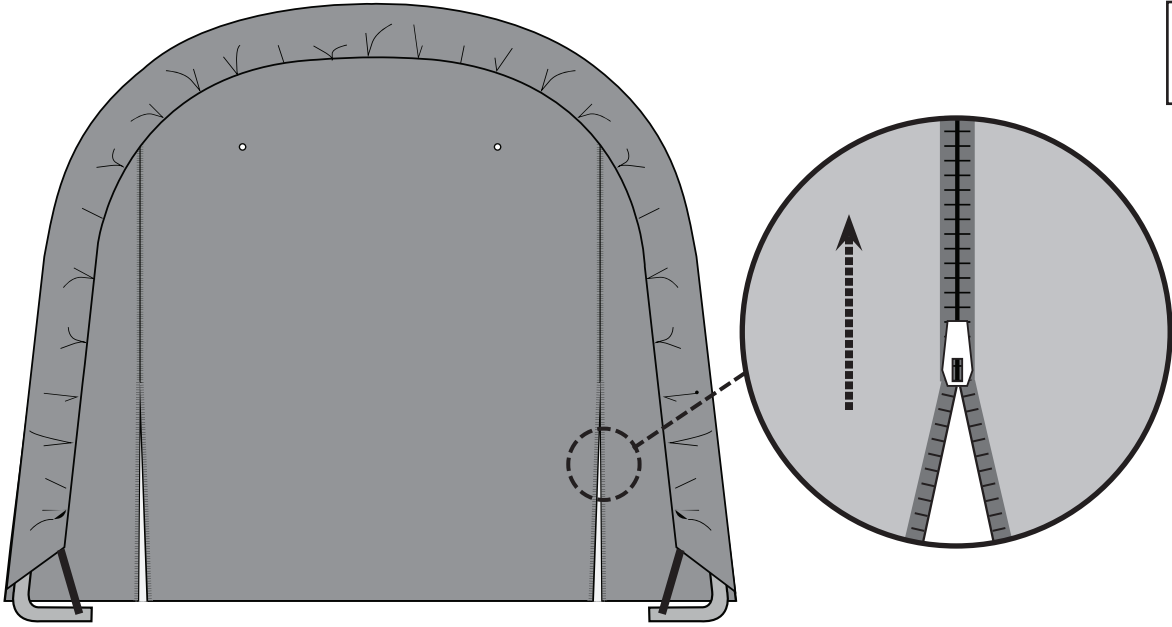

b.

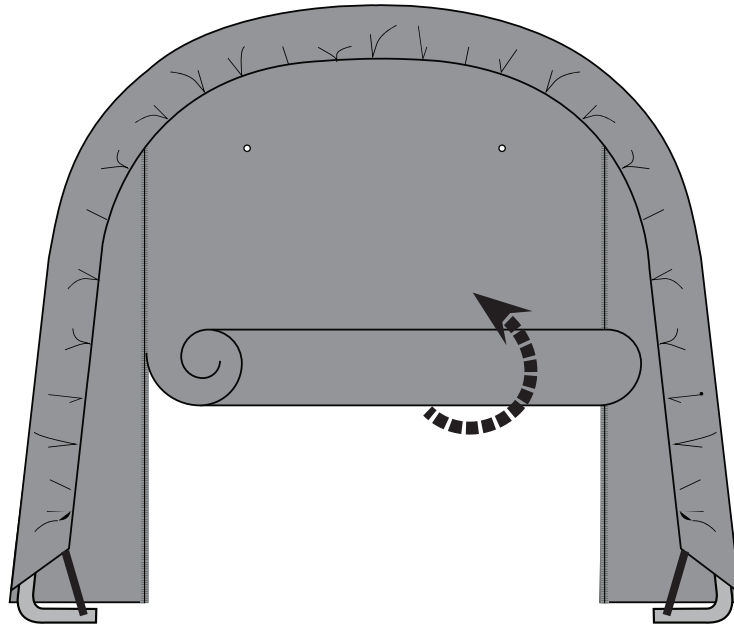

c.

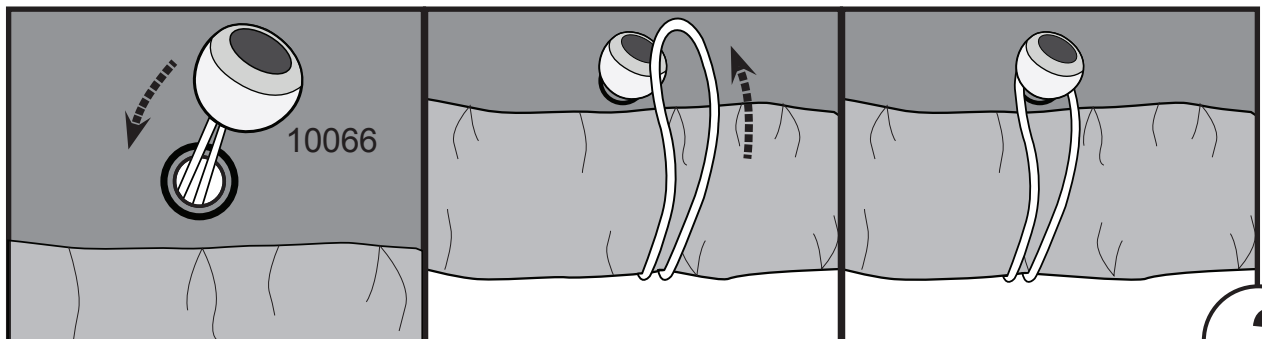

x2