

# RT16A6105SR

SAMSUNG

## Top Mount Refrigerator with All-Around Cooling 15.6 cu. ft. Capacity



### Signature Features

#### All-Around Cooling

All-Around Cooling and multi-vent technology maintain even air circulation on every shelf for a consistent temperature throughout.

#### Digital Inverter Compressor

Maintains both high levels of refrigerator humidity to keep perishable fruits and vegetables fresher longer, and dry freezer conditions means less freezer burn for better-tasting frozen foods.

#### Garage-Ready

Independent temperature sensors in fridge and freezer ensure efficient temperature operation in a wide range of surround temperature from 3.3 °C to 43 °C.

#### Fingerprint Resistant Finish

Avoid smudges with fingerprint resistant stainless steel.

#### Energy Star Certified

Eco-friendly and energy-efficient.

### Available Colours



Fingerprint Resistant  
Stainless Steel (shown)



White



Digital Inverter Compressor



All-Around Cooling

### Features

- Large Capacity – 15.6 cu. ft.
- ENERGY STAR® Compliant
- All-Around Cooling
- True No-Frost Technology
- LED Top Lighting
- Reversible Door
- Recessed Door Handle

### Rating



- ENERGY STAR® - Rated
- Energy Consumption (annual)  
= 345

# RT16A6105SR

# SAMSUNG

## Top Mount Refrigerator with All-Around Cooling 15.6 cu. ft. Capacity

### Installation Specifications

1. Measure the height, width and depth of the opening, making sure to include baseboards, molding tile, countertop overhang, etc. Check to be sure there is enough room to open the door (consider walls, islands or other obstacles when measuring).
2. Refer to illustration below to determine dimensions.
3. Allow 2.5" minimum clearance on hinge side of refrigerator when installing next to a wall where handle may make contact.
4. Allow 1" minimum clearance at rear for proper air circulation and water/ electrical connections. Allow a 3/8" minimum clearance at sides and top for ease of installation.
5. Ensure each door and entryway in the home is wide enough for the refrigerator to be moved through easily.

For optimal usage and to be able to open refrigerator doors completely, do not install next to a wall.

Please note: The following dimension and cutout information is for planning purposes only. For complete installation details, consult manual packed with product, or download manual online at [samsung.com](http://samsung.com).

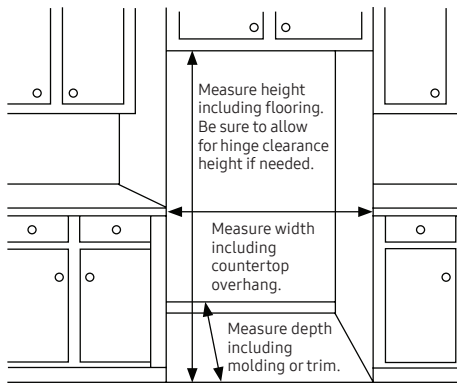

### Dimensions

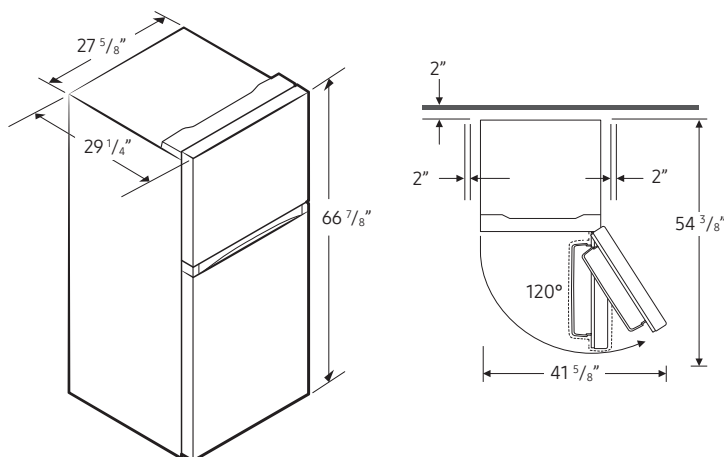

**Total Capacity: 15.6 cu. ft.**

### Refrigerator: 11.6

- 4 Tempered Glass Shelves
- 1 Crisper Drawer
- 3 Door Bins

### Fridge in Freezer: 4

- 1 Tempered Glass Shelf
- 2 Door Bins
- LED Top lighting

|                   |                    |
|-------------------|--------------------|
| Volt/Amps         | 115V / 60Hz / 3.5A |
| Power Cord Length | 2 meters           |

### Warranty

- One (1) Year Parts and Labour on Refrigerator
- Ten (10) Years Parts on Digital Inverter Compressor

### Product Dimensions & Weight (WxHxD)

Dimensions (WxHxD with hinges, handles and doors):

27 1/2" x 67 1/2" x 29 1/4"

Dimensions (WxHxD without hinges and door):

27 5/8" x 66 7/8" x 26 1/2"

Weight: 148 lbs (67kg)

### Shipping Dimensions & Weight (WxHxD)

Dimensions: 28 3/4" x 70 1/4" x 30 1/8"

Weight: 154 lbs (70kg)

### Colour

Fingerprint Resistant  
Stainless Steel

White

### Model #

RT16A6105SR

RT16A6105WW

### UPC

887276551395

887276574707