

H: 33 3/4" W: 23 7/8" D: 25 21/32" (with handle)

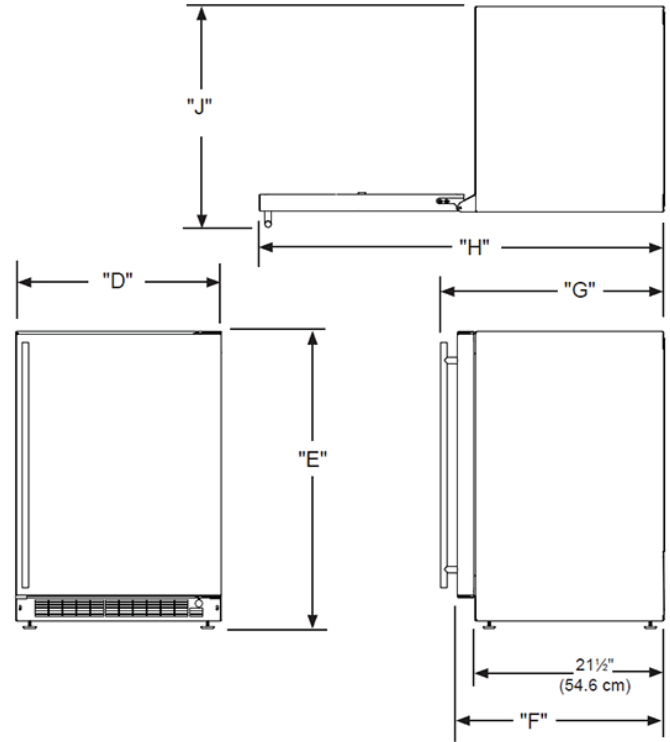
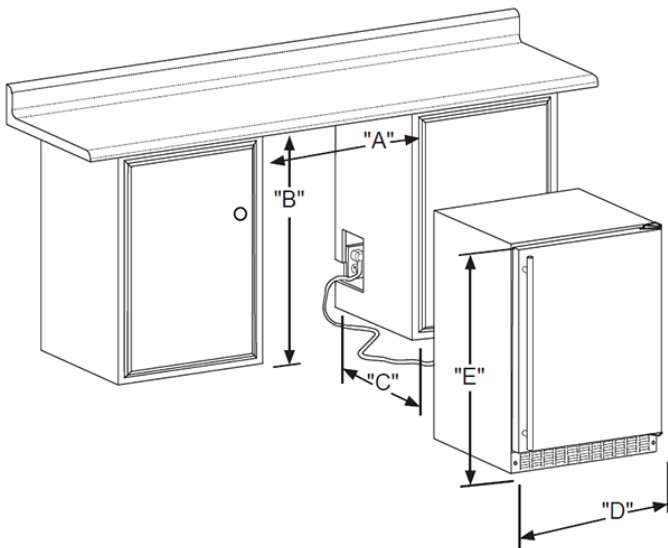

Rough In Dimensions

"A"	"B"	"C"
24"	34-1/4" to 35-1/4"	24"
(61 CM)	(87 CM to 89.5 CM)	(61 CM)

Cabinet Dimensions

"D"	"E"	"F"	"G"	"H"	"J"
23-7/8"	33-5/8" TO 34-5/8"	23-5/8"*	25-21/32"*	47-3/4"*	26-1/2"*
(60.7 CM)	(85.4 CM TO 87.9 CM)	(60 CM)	(65.2 CM)	(146.6 CM)	(67.3 CM)

Capacity	5.3 CU. FT.
Control Type	Electronic
Sabbath Mode	Yes
Temperature Range	34° F to 60° F
Handle Style	Slim
Hinge Type	Reversible
Interior Lighting	White LED
Shelving System	3/4 Extension Smooth-Glide Wire Shelving, (1) Fixed Wine Cradle
Toe Grille Finish	Black

Lock	No
Electrical Requirements	115V / 60 Hz / 15A
Cord Length	6 FT.
Shipping Dimensions	28" W x 31" D x 37" H
Shipping Weight	160 LBS
Agency Approval	UL
Refrigerant Type	R600a

For comprehensive installation instructions, please visit marvelrefrigeration.com to access the owner's guide.

