

SF5291

Freestanding / Semi Built-in

LIEBHERR

Refrigeration and Freezing



home.liebherr.com



SF5291

Energy consumption (kWh / y)	350
Estimated Yearly Energy Cost in US \$	49
Sound rating dB(A)	35
Refrigerator capacity cu.ft. (l)	-
BioFresh compartment cu.ft. (l)	-
Freezer capacity cu.ft. (l)	9.8 (278)
Electronic control	Touch & Swipe Display
Defrost type	Automatic
Interior light	LED
Number of shelves	-
Number of door racks	-
Number of FrostSafe drawers	7
Number of EasyFresh/BioFresh drawers	-
Refrigerator Temperature range °F (°C)	-
Freezer Temperature range °F (°C)	5° to -18°F (-15° to -28°C)
Water filter	1
Ice maker	IceTower
Ice cube output lbs. (kg.)	2.6 (1.2)
Ice cube stock lbs. (kg.)	17.6 (8)
Door hinges	left, reversible
Product dimensions	
in inch (H / W / D)	73 1/16" / 23 1/2" / 26 9/16"
in cm (H / W / D)	185.5 / 59.7 / 67.5
Cut out dimensions	
in inch (H / W / D)	74" / 24" / 24"
in cm (H / W / D)	188 / 60.9 / 60.9
Net weight lbs. (kg)	177 (80.3)
Voltage V / Hz	115/60

Accessories

Side By Side kit for models with handle 73"	9903598
Door opening limitation	9096414

Features

Super Frost

Simply quick freeze just-bought groceries to preserve optimum food freshness, while sealing in flavors and maintaining essential vitamins and minerals.

Ice Tower

You will never run out of cold drinks at your party. The ice cube scoop and the pull-out tray on telescopic rails allow easy access to the ice cubes.

Telescopic Rails

Telescopic rails a self-closing system for drawers ensures easy and convenient handling.

Soft System

SoftSystem integrated into the appliance door, cushions the door closure, thus eliminating slamming, even when the shelves are fully loaded.

Smart Steel

SmartSteel finish significantly reduces the visibility of fingerprints, is easy to clean, and is scratch resistant.

* Energy Cost will depend on utility rates and use. Estimated energy cost based on a national average electricity cost of 14 cents per kWh.

** Noise output – according to EN 60704-3

Diagrams

Product Dimensions

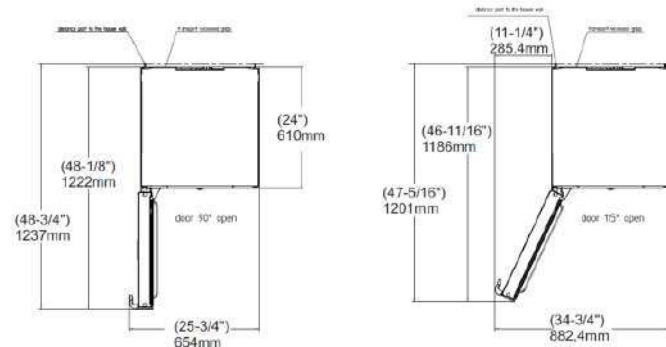
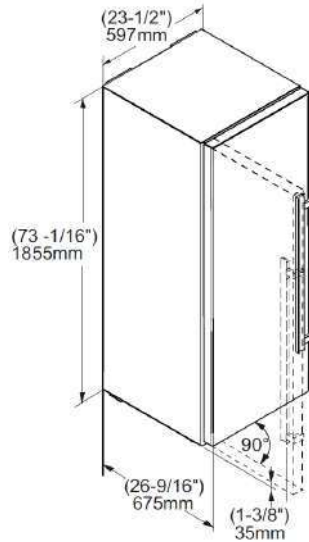

Allow door swing clearance at locations next to a wall. If the appliance is installed with the hinges next to a wall, the distance between the appliance and the wall must be at least 1 1/2" (40 mm). This is how far the handle protrudes when the door is open. The refrigerator door must open to a minimum of 90° to allow the crispers to open and the shelves to be removed. A 90° door limiter is available for this model as accessory. Height can be increased by 3/8" (10mm) by turning the levelling feet at the front and the height adjustable rollers at the appliance rear.

Semi built-in look – Cutout Dimensions

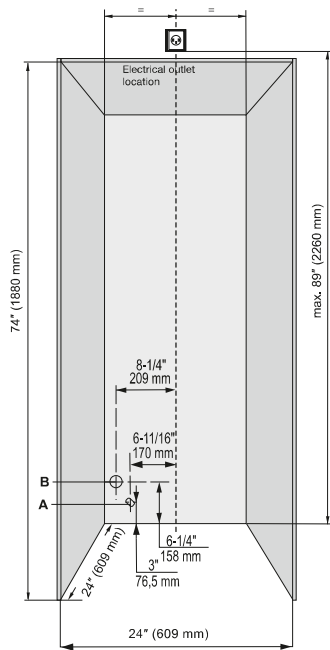

The appliances can be used freestanding or semi built-in. If semi built-in, consider the minimum cabinet opening dimensions specified on this image.

The power cord exists the rear of the appliances (A) right side and has a length of 6.5 ft (2m). We suggest the electrical outlet not to be located behind the appliance, so it is easily accessible. This can be located on top of the niche like shown on the image.

Do not install the shut-off valve for the water supply behind the appliance, to allow access to shut off without having to pull out the appliance. The water line lead out position is according to graphic (B).

Ventilation Requirements

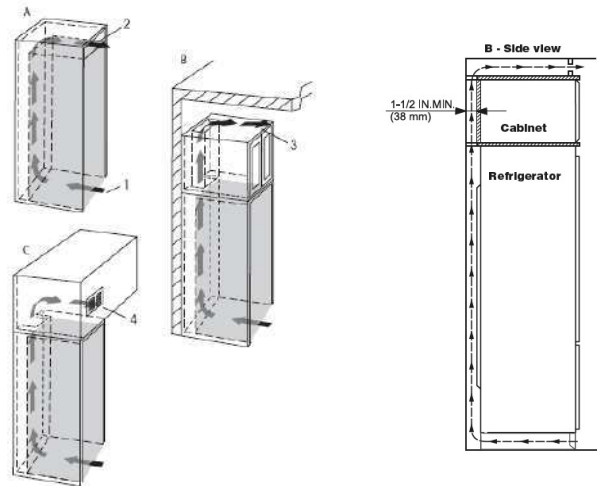

If the appliance is integrated in a fitted kitchen, the following ventilation requirements must be met: - The spacing fins on the back of the appliance are used to ensure sufficient ventilation. These must not lie in cavities or recesses in their final installation position. - Basically, the larger the ventilation gap, the more energy the appliance saves during operation. Do not restrict the air flow.

A cross-sectional air flow of at least 31 in² (200cm²) per appliance at the airflow inlet (1) and at the airflow outlet (2).

The top ventilation space can be directed in one of the following ways:

- A. Directly over the appliance (2) with a gap between the ceiling of the unit and the cabinet
- B. Above the cabinet and below the ceiling (3).
- C. Through a vent installed in a soffit (4).

Be sure to consider the possibility of having to raise some of the leveling legs in order to level the appliance when installing. If you adjust the height of the appliance – it will effectively reduce air flow. Therefore leave yourself some room for adjustment. The appliance is designed to allow proper air flow when installed up against the wall.