

dacor

User Manual

Contemporary Built-In Microwave Combi Oven

DOC30M977D*



To Our Valued Customer:

Congratulations on your purchase of the very latest in Dacor products! Our unique combination of features, style and performance make us a great addition to your home.

In order to familiarize yourself with the controls, functions and full potential of your new Dacor Appliance, read this use and care manual thoroughly, beginning with the **Before you begin** section.

All Dacor appliances are designed and manufactured with quality and pride, while working within the framework of our company value. Should you ever experience a problem with your product, please first check the Troubleshooting section of this manual for guidance. It provides useful suggestions and remedies prior to calling for service.

Valuable customer input helps us to continuously improve our products and services, so please feel free to contact our Customer Service Team for assistance with any of your product support needs.

Dacor Customer Assurance

- **USA**
Samsung Electronics America, Inc.
85 Challenger Road
Ridgefield Park, NJ 07660
- **Canada**
Samsung Electronics Canada Inc.
2050 Derry Road West, Mississauga,
Ontario L5N 0B9 Canada

Telephone: 833-353-5483(USA), 844-509-4659(Canada)

Hours of Operation: Mon – Fri, 8:00 a.m. to 8:00 p.m. Pacific Time

Website: www.dacor.com

Thank you for choosing Dacor for your home. We are a company built by families for families, and we are dedicated to serving yours. We are confident that your new Dacor product will deliver a high level of performance and enjoyment for many years to come.

Sincerely,

The Dacor Customer Assurance Team

Regulatory Notice

Precautions to avoid possible exposure to excessive microwave energy

- A. Do not attempt to operate this microwave oven with the door open since open-door operation can result in harmful exposure to microwave energy. It is important not to defeat or tamper with the safety interlocks.
- B. Do not place any object between the oven front face and the door or allow soil or cleaner residue to accumulate on the sealing surface.
- C. Do not operate the microwave oven if it is damaged. It is particularly important that the oven door close properly and that there is no damage to the:
 1. Door (bent),
 2. Hinges and latches, (broken or loosened),
 3. Door seals and sealing surface.
- D. The microwave oven should not be adjusted or repaired by anyone except properly qualified service personnel.

1. FCC Notice

FCC STATEMENT

This equipment generates and uses ISM frequency energy and if not installed and used properly, that is in strict accordance with the manufacturer's instructions, may cause interference to radio and television reception. It has been type tested and found to comply with limits for ISM Equipment pursuant to part 18 of FCC Rules, which are designed to part 18 of FCC Rules, which are designed to provide residential installation.

However, there is no guarantee that interference will not occur in a particular installation. If this equipment does cause interference to radio or television reception, which can be determined by turning the equipment off and on, the user is encouraged to try to correct the interference by one or more of the following:

- Reorient the receiving antenna of the radio or television.
- Relocate the Microwave Oven with respect to the receiver.
- Move the microwave oven away from the receiver.
- Plug the microwave oven into a different outlet so that the microwave oven and the receiver are on different branch codes.

Regulatory Notice

The manufacturer is not responsible for any radio or TV interference caused by unauthorized modification to this microwave oven. It is the responsibility of the user to correct such interference.

This equipment has been tested and found to comply with the limits for a Class B digital device, pursuant to part 15 of the FCC Rules. These limits are designed to provide reasonable protection against harmful interference in a residential installation. This equipment generates, uses and can radiate radio frequency energy and, if not installed and used in accordance with the instructions, may cause harmful interference to radio communications. However, there is no guarantee that interference will not occur in a particular installation. If this equipment does cause harmful interference to radio or television reception, which can be determined by turning the equipment off and on, the user is encouraged to try to correct the interference by one or more of the following measures:

- Reorient or relocate the receiving antenna.
- Increase the separation between the equipment and receiver.
- Connect the equipment into an outlet on a circuit different from that to which the receiver is connected.
- Consult the dealer or an experienced radio/TV technician for help.

To satisfy FCC RF exposure requirements, a separation distance of 20 cm or more should be maintained between the antenna of this device and persons during device operation.

To ensure compliance, operations at closer than this distance is not recommended.

WARNING : Any changes or modifications to this unit not expressly approved by the party responsible for compliance could void the user's authority to operate the equipment.

2. IC Notice

The term “IC” before the radio certification number only signifies that Industry Canada technical specifications were met. Operation is subject to the following two conditions: (1) this device may not cause interference, and (2) this device must accept any interference, including interference that may cause undesired operation of the device.

This Class B digital apparatus complies with Canadian ICES-003. For products available in the US/Canadian markets, only channels 1~11 are available. You cannot select any other channels.

IC RADIATION EXPOSURE STATEMENT:

This equipment complies with IC RSS-102 radiation exposure limits set forth for an uncontrolled environment. This equipment should be installed and operated so there is at least 8 inches (20 cm) between the radiator and your body. This device and its antenna(s) must not be co-located or operated in conjunction with any other antenna or transmitter.

Contents

| | |
|--|-----------|
| Important safety information | 8 |
| What you need to know about safety instructions | 8 |
| What the icons and signs in this user manual mean: | 8 |
| California Proposition 65 Warning | 9 |
| Grounding instructions | 11 |
| Use of extension cords | 11 |
| For your safety | 12 |
| Electrical safety | 14 |
| Child safety | 14 |
| Oven | 15 |
| Self-cleaning ovens | 16 |
| Ventilating hood | 16 |
| Critical installation warnings | 17 |
| Critical usage warning | 18 |
| Usage cautions | 21 |
| Critical cleaning warnings | 23 |
| Introducing your new oven | 24 |
| Overview | 24 |
| What's included with your oven | 25 |
| Before you begin | 27 |
| Energy saving tips | 27 |
| Optitray (For microwave oven) | 27 |
| Water reservoir | 28 |
| Basic operations | 30 |
| Control panel | 30 |
| Microwave | 31 |
| Display (Oven) | 32 |
| Control lockout | 33 |
| Kitchen timer | 34 |
| Microwave oven (Upper Oven) | 38 |
| Setting the power level | 38 |
| Timed cooking | 38 |
| Microwave | 40 |
| Convection Sear | 42 |
| Broil | 43 |
| Speed Conv.Sear | 44 |
| Speed Broil | 45 |
| Sense Cook™ | 46 |
| Conv.Sear AutoCook | 52 |
| Healthy Fry | 55 |
| Defrost | 58 |
| Healthy Choice | 60 |
| Auto Cook | 66 |
| Soften / Melt | 81 |

| | |
|--|------------|
| Oven (Lower Oven) | 83 |
| Timed cooking | 83 |
| Delay start | 84 |
| Using the temp probe | 86 |
| Oven functions | 89 |
| Using the special function feature | 98 |
| Using the iQ control feature (Lower oven only) | 102 |
| Using the oven racks | 104 |
| Using the gliding rack | 107 |
| Using the clean feature | 109 |
| Settings | 120 |
| Using the Sabbath feature | 124 |
| Maintaining your appliance | 126 |
| Care and cleaning of the oven | 126 |
| Removing the oven door (Lower oven only) | 130 |
| Replacing the oven door (Lower oven only) | 132 |
| Changing the oven light (Lower oven only) | 134 |
| Troubleshooting | 136 |
| Control display | 136 |
| For the microwave oven | 136 |
| For the lower oven | 141 |
| Information codes | 145 |
| Warranty and Service | 147 |
| Getting Help | 147 |
| Warranty | 147 |
| Appendix | 150 |
| Open source announcement | 150 |

Important safety information

Read and follow all instructions before using your oven to prevent the risk of fire, electric shock, personal injury, or damage when using the oven. This guide does not cover all possible conditions that may occur. Always contact your service agent or the manufacturer about problems that you do not understand.

What you need to know about safety instructions

Warnings and important safety instructions in this manual do not cover all possible conditions and situations that may occur. It is your responsibility to use common sense, caution, and care when installing, maintaining, and operating your oven.

What the icons and signs in this user manual mean:

WARNING









Hazards or unsafe practices that may result in severe personal injury or death.

CAUTION

Hazards or unsafe practices that may result in minor personal injury or property damage.

CAUTION

To reduce the risk of fire, explosion, electric shock, or personal injury when using your oven, follow these basic safety precautions.

| | |
|---|--|
|  | Do NOT attempt. |
|  | Do NOT disassemble. |
|  | Do NOT touch. |
|  | Follow directions explicitly. |
|  | Unplug the power plug from the wall socket. |
|  | Make sure the machine is grounded to prevent electric shock. |
|  | Call a Dacor service center for help. |
|  | Note |

These warning signs are here to prevent injury to you and others. Please follow them explicitly.

After reading this section, keep it in a safe place for future reference.

California Proposition 65 Warning

WARNING

Cancer and Reproductive Harm - www.P65Warnings.ca.gov.

WARNING

To reduce risk of burns, electric shock, fire, personal injury or exposure to excessive microwave energy:

1. Read all safety instructions before using the appliance.
2. Read and follow the specific “Precautions to avoid possible exposure to excessive microwave energy” on page 3.
3. This appliance must be grounded. Connect only to properly grounded outlets. See Important “Grounding instructions” on page 11 of this manual.
4. Install or locate this appliance only in accordance with the provided installation instructions.
5. Some products such as whole eggs and sealed containers (for example, closed glass jars) can explode if heated rapidly. Never heat them in a microwave oven.
6. Do not use this appliance for other purposes than cooking. Drying of clothing and heating of warming pads, slippers, sponges, damp cloth and similar may lead to risk of injury, ignition or fire. Use this appliance only for its intended use as described in the manual. Do not put corrosive chemicals or vapors in or on this appliance. This type of oven is specifically designed to heat, cook, or dry food. It is not designed for industrial or laboratory use.
7. As with any appliance, close supervision is necessary when it is used by children. Keep children away from the door when opening or closing it as they may bump themselves on the door or catch their fingers in the door.
8. Do not operate this appliance if it has a damaged cord or plug, if it is not working properly, or if it has been damaged or dropped.
9. This appliance should be repaired or serviced only by qualified service personnel. Contact the nearest authorized service facility for examination, repair, or adjustment.
10. Do not cover or block any openings in the appliance.
11. Do not tamper with or make any adjustments or repairs to the door.
12. Do not store this appliance outdoors. Do not use this product near water, for example, near a kitchen sink, in a wet basement, near a swimming pool, or similar locations.
13. Do not immerse the cord or plug in water.
14. Keep the cord away from heated surfaces (including the back of the oven).
15. Do not hang the cord over the edge of the table or counter.
16. When cleaning surfaces of the door and oven that come together when the door closes, use only mild, nonabrasive soaps, or detergents applied with a sponge or soft cloth. Unplug the plug before cleaning the unit.

Important safety information

- 17.** To reduce the risk of fire in the oven cavity:
 - Do not overcook food. Carefully attend the appliance when paper, plastic, or other combustible materials are placed inside the oven to facilitate cooking.
 - Remove wire twist-ties from paper or plastic bags before placing the bags in the oven.
- 18.** If materials inside the oven ignite, keep the oven door closed, turn the oven off, and disconnect the power cord, or shut off the power at the fuse or circuit breaker panel. If the door is opened, the fire may spread.
- 19.** Do not use the cavity for storage purposes. Do not leave paper products, cooking utensils, or food in the cavity when not in use.
- 20.** Liquids, such as water, milk, coffee, or tea can be overheated beyond the boiling point without appearing to be boiling. Visible bubbling or boiling when the container is removed from the microwave oven is not always present. THIS COULD RESULT IN VERY HOT LIQUIDS SUDDENLY BOILING OVER WHEN THE CONTAINER IS DISTURBED OR A SPOON OR OTHER UTENSIL IS INSERTED INTO THE LIQUID. To reduce the risk of injury:
 - Do not overheat liquid.
 - Stir liquid both before and halfway through heating it.
 - Do not use straight-sided containers with narrow necks.
 - After heating, let containers with liquid stand in the microwave oven for a short time before removing.
 - Use extreme care when inserting a spoon or other utensil into a container holding liquid.
- 21.** Oversized foods or oversized metal utensils should not be inserted into the microwave oven as they may create a fire or electric shock.
- 22.** Do not clean with metal scouring pads. Pieces can burn off the pad and touch electrical parts creating a risk of electric shock.
- 23.** Do not store any materials, other than manufacturer's recommended accessories, in this microwave oven when not in use.
- 24.** Do not cover the racks or any other part of the microwave oven with metal foil. This will cause overheating of the oven.

Grounding instructions

This appliance must be grounded. In the event of an electrical short circuit, grounding reduces the risk of electric shock by providing an escape wire for the electrical current. This appliance is equipped with a cord that includes a grounding wire and a grounding plug. The plug must be plugged into an outlet that is properly installed and grounded.

⚠ WARNING

Improper use of the grounding plug can result in a risk of electric shock.

- Plug into a grounded 3-prong outlet. Do not remove the third (grounding) prong. Do not use an adaptor or otherwise defeat the grounding plug.
- Consult a qualified electrician or service person if you do not understand the grounding instructions or if you are not sure if the appliance is properly grounded.
- We do not recommend using an extension cord with this appliance. If the power-supply cord is too short, have a qualified electrician or serviceman install an outlet near the appliance. However, if it is necessary to use an extension cord, read and follow the “Use of Extension Cords” section below.

Use of extension cords

A short power-supply cord is provided to reduce the risk of your becoming entangled in or tripping over a longer cord. Longer cord sets or extension cords are available and you can use them if you exercise care. If you use a long cord or extension cord:

1. The marked electrical rating of the cord set or extension cord should be at least as great as the electrical rating of the appliance.
2. The extension cord must be a grounding-type 3-wire cord and it must be plugged into a 3-slot outlet.
3. The longer cord should be arranged so that it will not drape over the counter top or tabletop where it can be pulled on by children or tripped over accidentally. If you use an extension cord, the interior light may flicker and the speed of the blower may vary when the microwave oven is on. Cooking times may be longer too.

Important safety information

For your safety

When using electrical appliances, you should follow basic safety precautions, including the following:

CAUTION

- Use this appliance only for its intended purpose as described in this Owner's Manual.
- Potentially hot surfaces include the oven vent opening, surfaces near the opening, and crevices around the oven door.



Proper Installation - Be sure your appliance is properly installed and grounded by a qualified technician.



User servicing - Do not repair or replace any part of the appliance unless specifically recommended in this manual. All other servicing should be referred to a qualified technician.

Always disconnect the power to the appliance before servicing by removing the fuse or switching off the circuit breaker.



- **Do not enter the oven.**
- **Do not leave children alone.** Never leave children alone or unattended in an area where this appliance is in use. They should never be allowed to sit or stand on any part of the appliance.
- **Never use your appliance for warming or heating the room.**
- **Do not use water on grease fires.** Turn off the oven to avoid spreading the flames. Smother the fire or flames by closing the door or use a dry chemical, baking soda, or foam-type extinguisher.
- Avoid scratching or striking the glass doors and the control panel. Doing so may lead to glass breakage. Do not cook on a product with broken glass. Shock, fire, or cuts may occur.
- If there is a fire in the oven during self-cleaning, turn the oven off and wait for the fire to go out. Do not force the door open. The introduction of fresh air at self-cleaning temperatures may lead to a burst of flame from the oven. Failure to follow these instructions may result in severe burns.
- If the oven is heavily soiled with oil, self-clean the oven before using the oven again. Leaving the oil in place creates a risk of fire.
- Wipe up heavy soil on the oven bottom with a paper towel or rag before self-cleaning. Self-cleaning the oven when there is heavy soil on the oven bottom requires longer cleaning cycles and produces more smoke.

-
- ★ • **Storage in or on the appliance.** Do not store flammable materials in the oven or near the surface units. Be sure all packing materials are removed from the appliance before operating it. Keep plastics, clothes, and paper away from parts of the appliance that may become hot.
 - **Wear proper apparel.** Never wear loose-fitting or hanging garments while using the appliance.
 - **Use only dry potholders.** Placing moist or damp potholders on hot surfaces may result in burns from steam. Do not let the potholder touch hot heating elements. Do not use a towel or other bulky cloth instead of a potholder.
 - Teach children not to play with the controls or any other part of the oven.
 - For your safety, do not use high-pressure water cleaners or steam jet cleaners to clean any part of the oven.
 - If the power cord is damaged, it must be replaced by the manufacturer, its service agent, or similarly qualified persons to avoid creating a hazard.
 - The appliance is not intended for use by persons (including children) with reduced physical, sensory or mental capabilities, or lack of experience and knowledge, unless they have been given supervision or instruction concerning use of the appliance by a person responsible for their safety.

Important safety information

Electrical safety



- Use only the factory installed flexible power cord to connect to the power supply. Do not use a 3rd party power supply cord kit.
- The appliance should be serviced only by qualified service personnel. Repairs carried out by unqualified individuals may cause injury or a serious malfunction. If your appliance is in need of repair, contact a Dacor authorized service center. Failure to follow these instructions may result in damage and void the warranty.
- Flush - mounted appliances may be operated only after they have been installed in cabinets and workplaces that conform to the relevant standards. This ensures that the appliances are installed in compliance with the appropriate safety standards.
- If your appliance malfunctions or if fractures, cracks, or splits appear:
 - Switch off the oven.
 - Unplug the oven from the AC wall outlet.
 - Contact your local Dacor service center.

WARNING

Ensure that the appliance is switched off before replacing the lamp to avoid the possibility of electric shock.

Child safety

WARNING

- This appliance is not intended for use by young children or infirm persons without the adequate supervision of a responsible adult.
- Young children should be supervised to ensure that they do not play with the appliance.
- Keep children away from the door when opening or closing it as they may bump themselves on the door or catch their fingers in the door.

During self-cleaning, the surfaces may get hotter than usual. Keep small children away from the oven when it is in the self-cleaning mode.

WARNING

Accessible parts may become hot during use. To avoid burns, young children should be kept away.

Oven

- ☐ • **DO NOT TOUCH THE HEATING ELEMENTS OR INTERIOR SURFACES OF THE OVEN.** Heating elements may be hot even though they are dark in color. Interior surfaces of an oven become hot enough to cause burns. During and after use, do not touch or let clothing or other flammable materials contact the heating elements or interior surfaces of the oven until they have had sufficient time to cool. Other surfaces of the appliance may become hot enough to cause burns. Among these surfaces are oven vent openings and surfaces near these openings, the oven door, and the window of the oven door.
- **Do not heat unopened food containers.** The build-up of pressure may cause the container to burst and result in injury.
- **Do not use the oven to dry newspapers.** If overheated, newspapers can catch fire.
- **Do not use the oven for a storage area.** Items stored in an oven can ignite.
- ★ • **Use care when opening the door.** Let hot air or steam escape before you remove food from or put food into the oven.
- **Protective liners.** Do not use aluminum foil to line the oven bottoms, except as suggested in this manual. Improper installation of these liners may result in a risk of electric shock or fire.
- **Placement of oven racks.** Always place oven racks in the desired location while the oven is cool. If the rack must be moved while the oven is hot, use potholders. Do not let the potholders come in contact with the hot heating element in the oven.
- ☐ • Do not allow aluminum foil or a meat probe to contact the heating elements.
- **During use, the appliance becomes hot.** Care should be taken to avoid touching heating elements inside the oven.
- Do not use harsh abrasive cleaners or sharp metal scrapers to clean the oven door glass. They can scratch the surface which may result in the glass shattering.

CAUTION

Do not attempt to operate the oven during a power failure. If the power fails, always turn the oven off. If the oven is not turned off and the power returns, the oven may begin to operate again. Food left unattended could catch fire or spoil.

Important safety information

Self-cleaning ovens





- ☐ Do not clean the door gasket. The door gasket is essential for a good seal. Care should be taken not to rub, damage, or move the gasket.
- ★
 - **Never keep pet birds in the kitchen.** Birds are extremely sensitive to the fumes released during an oven self-clean cycle. Fumes may be harmful or fatal to birds. Move birds to a well-ventilated room.
 - **Clean only the parts listed in this manual in the self-clean cycle.** Before self-cleaning the oven, remove the partition, rack, utensils, and any food.
 - Before operating the self-clean cycle, wipe grease and food soils from the oven. Excessive amounts of grease may ignite, leading to smoke damage to your home.
 - Do not use any commercial oven cleaner or oven liner protective coating of any kind in or on the outside of the oven.
 - Remove the nickel oven shelves from the oven before you begin the self-cleaning cycle or they may discolor.
 - If the self-cleaning mode malfunctions, turn the oven off and disconnect the power supply. Have it serviced by a qualified technician.
 - Excess spillage must be removed before you run the self-cleaning cycle.

Ventilating hood

- ★
 - **Clean ventilating hoods frequently.** Do not let grease accumulate on the hood or filter.
 - **When flaming foods under the hood, turn the fan on.**

Critical installation warnings



WARNING

-  • This appliance must be installed by a qualified technician or service company.
 - Failing to have a qualified technician install the oven may result in electric shock, fire, an explosion, problems with the product, or injury.
- Unpack the oven, remove all packaging material and examine the oven for any damage such as dents on the interior or exterior of the oven, broken door latches, cracks in the door, or a door that is not lined up correctly. If there is any damage, do not operate the oven and notify your dealer immediately.
- Keep all packaging materials out of the reach of children. Children may use them for play and injure themselves.
-  • This appliance must be properly grounded.
- Do not ground the appliance to a gas pipe, plastic water pipe, or telephone line.
 - This may result in electric shock, fire, an explosion, or problems with the product
- Do not cut or remove the ground prong from the power cord under any circumstances.
- Connect the oven to a circuit that provides the correct amperage.
-  • Do not install this appliance in a humid, oily or dusty location, or in a location exposed to direct sunlight or water (raindrops).
 - This may result in electric shock or fire.
- Do not use a damaged power cord or loose wall socket.
 - This may result in electric shock or fire.
- Do not pull or excessively bend the power cord.
- Do not twist or tie the power cord.
- Do not hook the power cord over a metal object, place a heavy object on the power cord, or insert the power cord between objects.
 - This may result in electric shock or fire.
-  If the power cord is damaged, contact your nearest Dacor service center.

Important safety information

Critical usage warning

CAUTION

-  • If the appliance is flooded by any liquid, please contact your nearest Dacor service center. Failing to do so may result in electric shock or fire.
- If the appliance produces a strange noise, a burning smell, or smoke, unplug the power plug immediately and contact your nearest Dacor service center.
 - Failing to do so may result in electric shock or fire
- In the event of a gas leak (such as propane gas, LP gas, etc.), ventilate the area immediately. Do not touch the power cord. Do not touch the appliance.
 - A spark may result in an explosion or fire.
- Take care not to contact the oven door, heating elements, or any of the other hot parts with your body while cooking or just after cooking.
 - Failing to do so may result in burns.
- If materials inside the oven should ignite, keep the oven door closed, turn the oven off and disconnect the power cord, or shut off power at the fuse or circuit breaker panel. If the door is opened, the fire may spread.
- Always observe safety precautions when using your oven. Never try to repair the oven on your own - there is dangerous voltage inside. If the oven needs to be repaired, contact an authorized Dacor service center near you.
- If you use the appliance when it is contaminated by foreign substances such as food waste, it may result in a problem with the appliance.
- Take care when removing the wrapping from food taken out of the appliance.
 - If the food is hot, hot steam may be emitted abruptly when you remove the wrapping and this may result in burns.
-  • Do not attempt to repair, disassemble, or modify the appliance yourself.
 - Since a high voltage current enters the product chassis, it may result in electric shock or fire.
 - When a repair is needed, contact your nearest Dacor service center.
-  • If any foreign substance such as water has entered the appliance, contact your nearest Dacor service center.
 - Failing to do so may result in electric shock or fire.

-
- ☐ • Do not touch the power cord with wet hands.
 - This may result in electric shock.
 - Do not turn the appliance off while an operation is in progress.
 - This may cause a spark and result in electric shock or fire.
 - Do not let children or any person with reduced physical, sensory, or mental capabilities use this appliance unsupervised.
 - Make sure that the appliance's controls and cooking areas are out of the reach of children.
 - Failing to do so may result in electric shock, burns, or injury.
 - Do not touch the inside of the appliance immediately after cooking. The inside of the appliance will be hot.
 - Failing to do so may result in burns.
 - Do not use or place flammable sprays or objects near the oven.
 - Flammable items or sprays can cause fires or an explosion.
 - Do not insert fingers, foreign substances, or metal objects such as pins or needles into inlets, outlets, or holes. If foreign substances are inserted into any of these holes, contact your product provider or nearest Dacor service center.
 - Do not tamper with or make any adjustments or repairs to the door. Under no circumstances should you remove the door or outer shell of the oven.
 - Do not store or use the oven outdoors.
 - Never use this appliance for purposes other than cooking.
 - Using the appliance for any purpose other than cooking may result in fire.
 - Open the cap or stopper of sealed containers (herb tonic tea bottle, baby bottle, milk bottle and so on) before heating them. Make a hole in food items that have shells (eggs, chestnuts, etc) with a knife before cooking them.
 - Failing to do so may result in burns or injury.
 - Never heat plastic or paper containers and do not use them for cooking.
 - Failing to do so may result in fire.



Important safety information



- Do not heat food wrapped in paper from magazines, newspapers, etc.
 - This may result in fire.
- Do not open the door when the food in the oven is burning.
 - If you open the door, it causes an inflow of oxygen and may cause the food to ignite.
- Do not apply excessive pressure to the door or the inside of the appliance. Do not strike the door or the inside or the appliance.
 - Hanging on to the door may result in the product falling and cause serious injury.
 - If the door is damaged, do not use the appliance. Contact a Dacor service center.
- Do not hold food in your bare hands during or immediately after cooking.
 - Use oven mitts. The food may be very hot and you could burn yourself.
 - As the handle and oven surfaces may be hot enough to cause burns after cooking, use oven mitts to protect your hands from burns.

Usage cautions

CAUTION

-  • If the surface is cracked, turn the appliance off.
 - Failing to do so may result in electric shock.
- Dishes and containers can become hot. Handle with care.
- Hot foods and steam can cause burns. Carefully remove container coverings, directing the steam away your hands and face.
- Remove lids from baby food jars before heating. After heating baby food, stir well to distribute the heat evenly. Always test the temperature by tasting before feeding the baby. The glass jar or the surface of the food may appear to be cooler than the interior, which can be hot enough to burn an infant's mouth.
- Take care as beverages or food may be very hot after heating.
- Take care when heating liquids such as water or other beverages.
 - Make sure to stir during or after cooking.
 - Avoid using a slippery container with a narrow neck.
 - Wait at least 30 seconds after heating before removing the heated liquid, failing to do so may result in an abrupt overflow of the contents and cause burns.
-  • Do not stand on top of the appliance or place objects (such as laundry, an oven cover, lighted candles, lighted cigarettes, dishes, chemicals, metal objects, etc.) on the appliance.
 - Items, such as a cloth, may get caught in the door.
 - This may result in electric shock, fire, problems with the product, or injury.
- Do not operate the appliance with wet hands.
 - This may result in electric shock.
- Do not spray volatile substances such as insecticide onto the surface of the appliance.
 - As well as being harmful to humans, it may also result in electric shock, fire, or problems with the product.

Important safety information



- Do not put your face or body close to the appliance while cooking or when opening the door just after cooking.
 - Take care that children do not come too close to the appliance.
 - Failing to do so may result in children burning themselves.
- Do not place food or heavy objects over the edge of the oven door.
 - If you open the door, the food or object may fall and this may result in burns or injury.
- Do not abruptly cool the door, the inside of the appliance, or a dish by pouring water over it during or just after cooking.
 - This may result in damage to the appliance. The steam or water spray may result in burns or injury.
- Do not operate while empty except for self-cleaning.
- Do not defrost frozen beverages in narrow-necked bottles. The bottles can break.
- Do not scratch the glass of the oven door with a sharp object.
 - This may result in the glass being damaged or broken.
- Do not store anything directly on top of the appliance when it is in operation.
- Do not use sealed containers. Remove seals and lids before cooking. Sealed containers can explode due to the buildup of pressure even after the oven has been turned off.
- Take care that food you are cooking in the oven does not come into contact with the heating element.
 - This may result in fire.
- Do not overheat food.
 - Overheating food may result in fire.
- Use caution when opening or closing the door. Your fingers may be pinched, resulting in physical injury.
- The door has wires at the bottom for connecting LED lights. Be careful not to pull or cut the wires when handling the door.

Critical cleaning warnings

CAUTION



- Do not clean the appliance by spraying water directly on to it.
- Do not use benzene, thinner, or alcohol to clean the appliance.
 - This may result in discoloration, deformation, damage, electric shock, or fire.
- Take care not to hurt yourself when cleaning the appliance (externally or internally).
 - You may hurt yourself on the sharp edges of the appliance.
- Do not clean the appliance with a steam cleaner.
 - This may result in corrosion.
- Keep the inside of the oven clean. Food particles or spattered oils stuck to the oven walls or floor can cause paint damage and reduce the efficiency of the oven.

Introducing your new oven

Overview

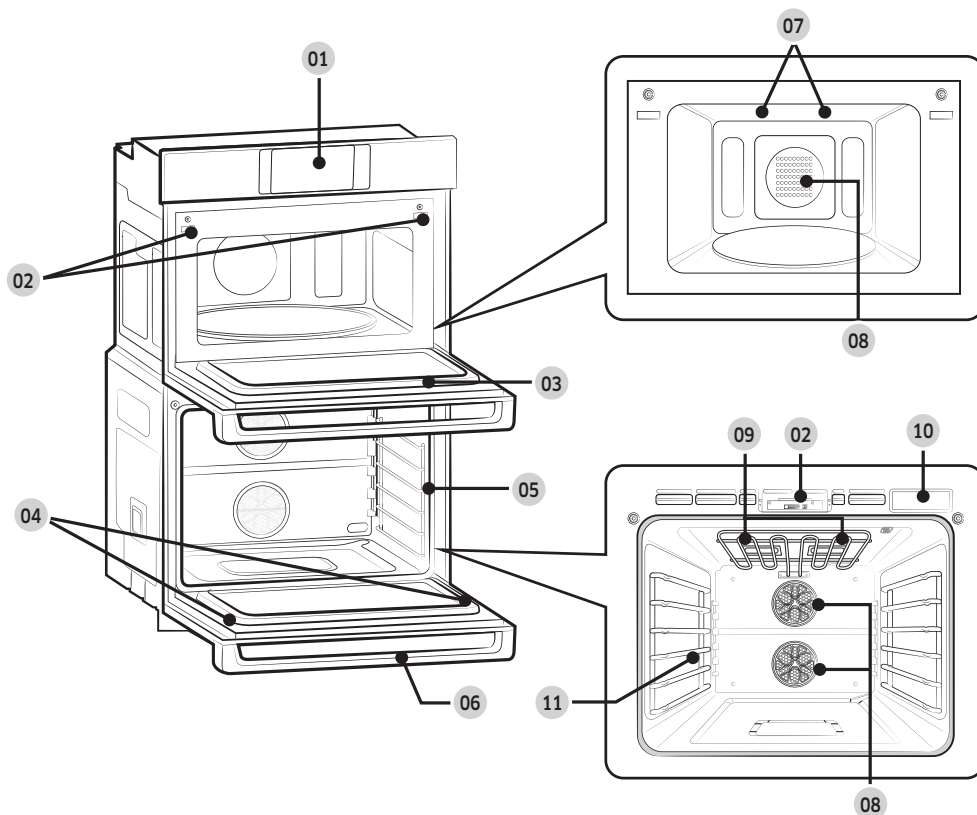

01 Control panel

04 Door LED light

07 LED lamp

10 Water reservoir

02 Door latch

05 Oven gasket

08 Convection fan

11 Rack support

03 MWO door

06 Oven door

09 Halogen lamp

What's included with your oven

This oven ships with different kinds of accessories that help you cook what you want.

Accessories for oven

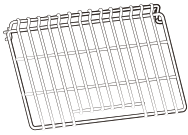

Wire rack (1)

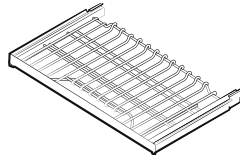

Gliding racks (2)

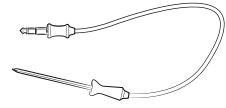

Temp probe (1)

| | |
|----------------------|--|
| Wire rack | Use these racks in the lower oven when baking and broiling. |
| Gliding racks | The fully extendable Gliding Rack makes food preparation easier, especially when you are preparing heavier dishes. |
| Temp probe | The Temp probe lets you cook meat to the exact internal temperature you want, taking the guess work out of determining whether a piece of meat is done or not. |

Introducing your new oven

Accessories for microwave

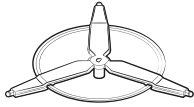

Roller ring

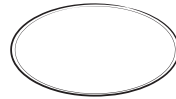

Optitray



Even plate

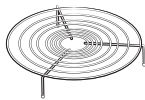

Low rack

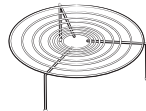

High rack

| | |
|-------------|---|
| Roller ring | Put in the center of the base. It supports the optitray. |
| Optitray | Put on the roller ring with the center fitting of the coupler. It serves as a cooking base. |
| Racks | Use one of these racks as appropriate to cook two dishes simultaneously. A smaller dish on the optitray, and the other on the selected rack. You can use these racks with Broil or Convection function. NOTE Do not use wire racks with Microwave mode except where specifically noted in this manual. |
| Even plate | Put on the optitray. Use this to brown food, or to keep pastries or pizza crisp. |

NOTE

- Do not use the optitray without the roller ring.
- If you need additional accessories, you can buy it from the Dacor Customer Service 833-353-5483(USA), 844-509-4659(Canada).

Before you begin

Before using the top and bottom ovens for the first time, remove all the accessories, and then clean the ovens thoroughly. Then, set the lower oven to Bake, and run it at 400 °F for 1 hour. Next, set the microwave (top) oven to Power Convection, and then run it at 400 °F for 1 hour. There will be a distinctive odor. This is normal.

Ensure your kitchen is well ventilated during this conditioning period.

Energy saving tips

- During cooking, the oven door should remain closed except when you turn food over. Opening the door frequently during cooking lowers the oven temperature and wastes energy.
- If cooking time is more than 30 minutes, you can switch the oven off 5-10 minutes before the end of the cooking time to save energy. The residual heat will complete the cooking process.
- To save energy and reduce the time needed for re-heating the oven, plan oven use to avoid turning the oven off between cooking one item and the next.
- Whenever possible, cook more than one item at a time.

Optitray (For microwave oven)

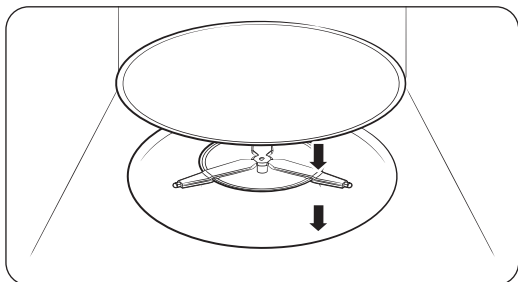

Remove all packing materials inside the oven. Install the roller ring and optitray. Check that the optitray rotates freely.

Before you begin

Water reservoir

The water reservoir is used for the Steam Bake, Steam Roast and GreenClean™ functions and also to remove water scale that may form on the oven walls, especially after Steam Baking, Steam Roasting, and Green cleaning. Fill it with water in advance of steam cooking or descaling.

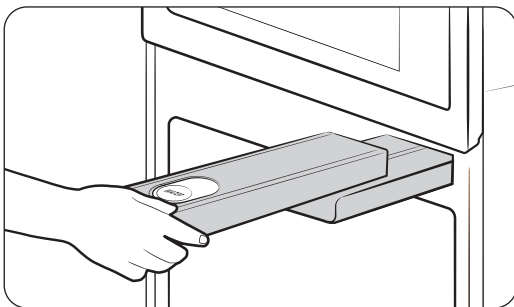
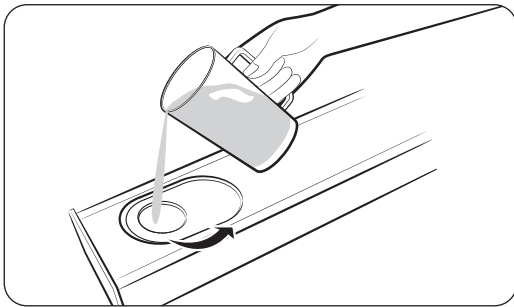
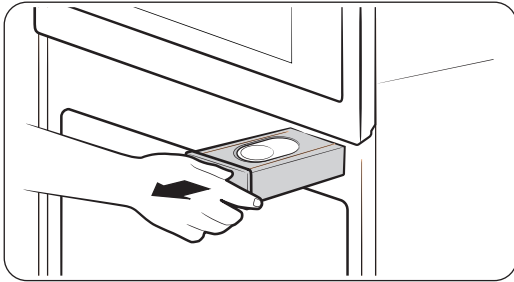

1. Locate the water reservoir. The water reservoir is on the right side of the oven, just above the oven opening. Touch **Reservoir** on the control panel. The oven ejects the water reservoir. Grasp the front of the reservoir, and then slide it out to remove.

2. Open the reservoir cap, and then fill the reservoir with 22 oz (650 ml) of tap water.

 **NOTE**

You can open the reservoir by removing the rubber cap or by removing the clear plastic top.

3. Replace the cap or the clear plastic top, and then slide the water reservoir back into the reservoir slot.
4. Push the reservoir in. There will be soft click when it is in place correctly. Touch **Reservoir**. The oven retracts the water reservoir.
5. Close the oven door.

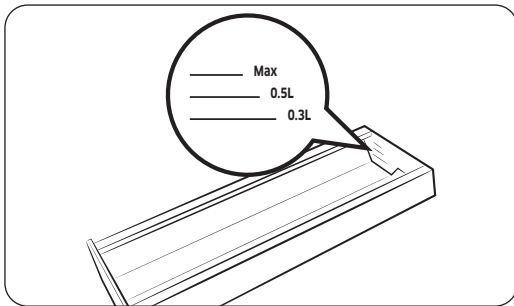
**NOTE**

Do not exceed the max line.

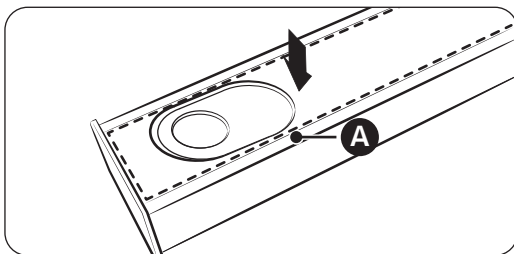
**NOTE**

Make sure the cap and the upper portion of the water reservoir (**labeled A**) are closed before using the oven.

CAUTION

The water reservoir becomes hot during cooking. Make sure you wear oven mitts to remove or refill the water reservoir.

Basic operations

Control panel

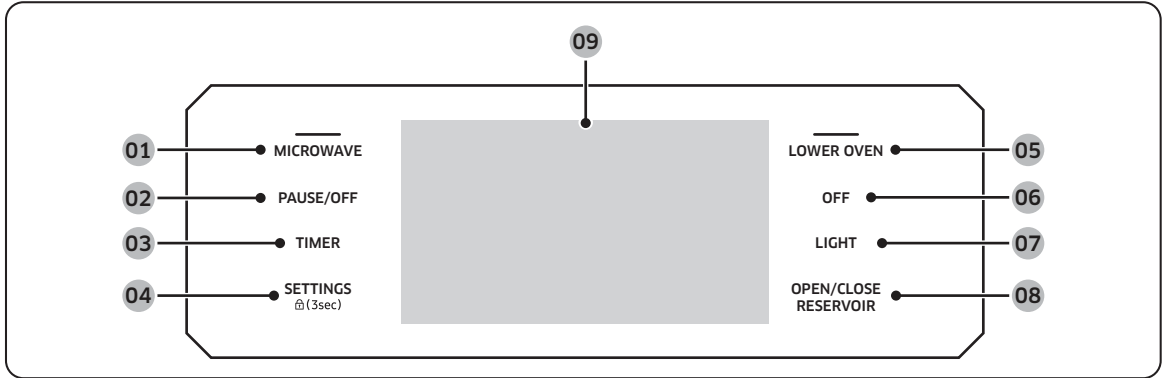

- 01 MICROWAVE:** Use to display the upper Microwave oven mode screen on the display. Touching here does not turn the oven on or off. It only displays its current status.
- 02 PAUSE/OFF:** Use to pause or cancel when microwave is cooking.
- 03 TIMER:** Use to display the set Timer screen.
- 04 SETTINGS and Control Lockout:** Use to display the Setting screen. If you touch and hold this key for 3 seconds, all oven functions will be disabled.
- 05 LOWER OVEN:** Use to display the lower oven mode screen on the display. Touching here does not turn the oven on or off. It only displays its current status.
- 06 OFF:** Use to cancel when lower oven is cooking.
- 07 LIGHT:** Use to turn the oven light on or off.
- 08 OPEN/CLOSE RESERVOIR:** Touch to open or close the water reservoir.
- 09 Display:** Swipe to navigate through the menus and tap to select a desired setting.

NOTE

If you tap the display while wearing plastic or oven gloves, the display will not operate properly. Take the gloves off first, and then tap with a bare finger.

Microwave

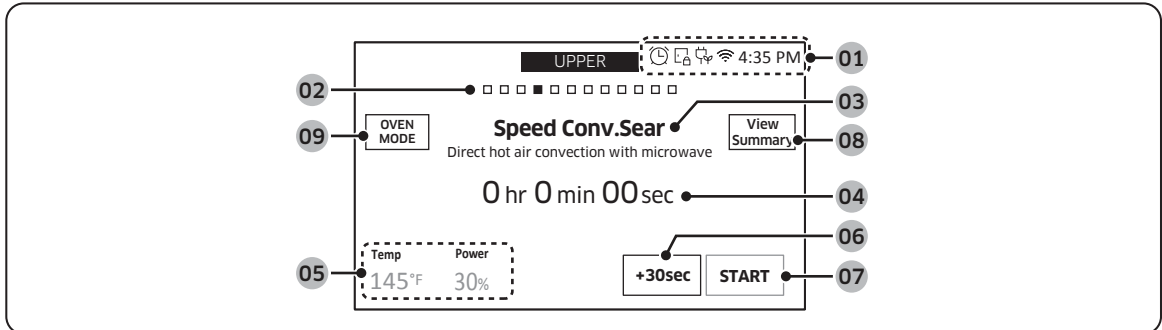

01 Indicator area

- **Timer** (⌚): When the timer is set, the timer indicator is displayed. When more than 2 timers are set, the number of set timers is shown.
- **Door lock** (🔒): Displayed when the oven door is locked.
- **Wi-Fi** (📶): Shows Wi-Fi signal strength in 5 steps.
- **12-hour energy saving** (🌙): Displayed when 12-hour energy saving is turned on.
- **Current time**: The current time is displayed.

02 Page Indicator: Shows location of current mode.

03 Mode: The current or selected menu is displayed with a mode description.

04 Cook Time: The cooking time is displayed. When you tap this area, the cooking time screen is displayed.

05 Information area

- **Temp.**: The current or selected temperature is displayed. When you tap this area, the temperature adjustment screen is displayed.
- **Power**: Power level of microwave is displayed. When you tap this area, power level adjustment screen is displayed.

06 +30sec: You can add 30 seconds to cooking time before you start cooking and during cooking.

07 START: Tap to start the oven using the displayed settings.

08 View Summary: When you tap this area, cooking modes of upper and lower oven are displayed.

09 OVEN MODE: When you tap this area, you can choose the upper oven mode.

Basic operations

Display (Oven)

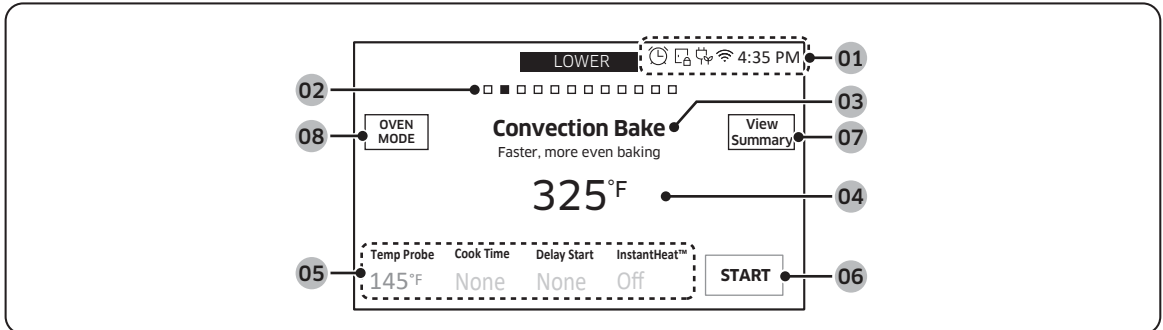

01 Indicator area

- **Timer** (⌚): When the timer is set, the timer indicator is displayed. When more than 2 timers are set, the number of set timers is shown.
- **Door lock** (🔒): Displayed when the oven door is locked.
- **Wi-Fi** (📶): Shows Wi-Fi signal strength in 5 steps.
- **12-hour energy saving** (🌙): Displayed when 12-hour energy saving is turned on.
- **Current time**: The current time is displayed.

02 Page Indicator: Shows location of current mode.

03 Mode: The current or selected menu is displayed with a mode description.

04 Temperature: The current or selected temperature is displayed. When you tap this area, the temperature adjustment screen is displayed.

05 Information area

- **Temp Probe**: The set temperature of the temp probe is displayed. When you tap this area, the Temp Probe screen is displayed.
- **Cook Time**: The cooking time is displayed. When you tap this area, the cooking time screen is displayed.
- **Delay Start**: The delay start time is displayed. When you tap this area, the Delay Start screen is displayed.
- **InstantHeat™**: Indicates if the InstantHeat™ feature is on or off. (Only displayed when you are using the Convection Bake or Convection Roast mode.)
- **Steam**: The steam level is displayed. When you tap this area, the steam level screen is displayed. (Only displayed when you are using the Steam Bake or Steam Roast mode.)

06 START: Tap to start the oven using the displayed settings.

07 View Summary: When you tap this area, cooking modes of upper and lower oven are displayed.

08 OVEN MODE: When you tap this area, you can choose the lower oven mode.

Control lockout

Control Lockout lets you lock the buttons on the touch pad so they cannot be activated accidentally. Control Lock locks only the lower oven door so it cannot be opened. You can only activate Control Lockout when the oven is in standby mode.

How to activate the control lockout feature

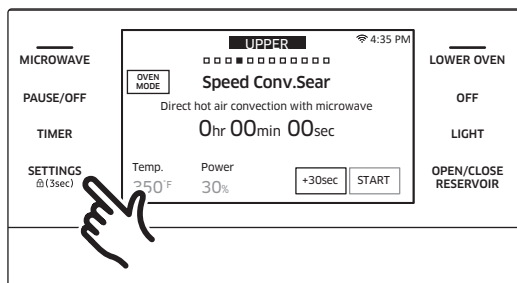

1. Cancel or turn off all functions.
2. Touch **SETTINGS** for 3 seconds.

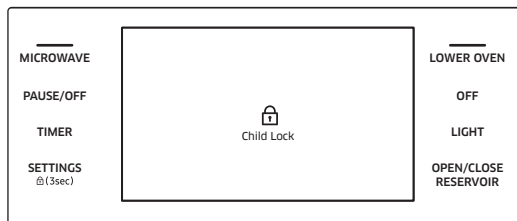

3. The display will change to the control lock screen and the control lock confirmation will appear at the bottom of the screen.

NOTE

- Control Lockout is available only when the oven temperature is under 400 °F.
- All other functions must be cancelled before you activate Control Lockout.

How to unlock the controls

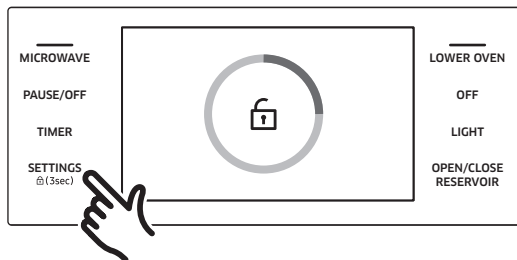

Touch **SETTINGS** for 3 seconds. The control lock confirmation and the lock icon will disappear from the display.

NOTE

It may take up to 10 seconds for the doors to unlock.

Basic operations

Kitchen timer

The kitchen timer serves as an extra timer that will beep when the set time has elapsed. It does not start or stop cooking functions. You can use the kitchen timer with any of the other oven functions. You can set 10 timers maximum simultaneously. Each timer will count down independently of all the other active timers.

How to set the timer

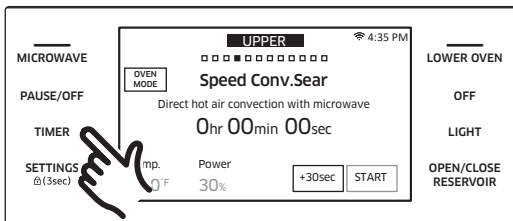

1. Touch **TIMER**.
The display will change to the timer screen.

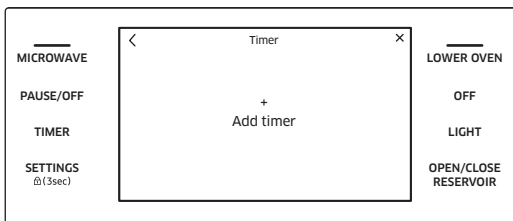

2. Tap + Add timer.

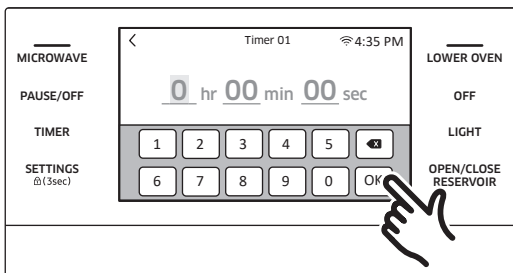

3. Tap the numbers in the numeric pad to set the timer. (You can set the timer for any amount of time from 1 sec to 23 hr 59 min 59 sec).
4. Tap **OK**.

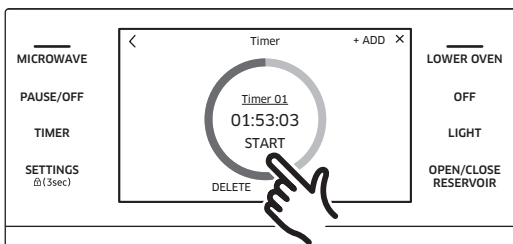

5. Tap **START**.
When the set time has elapsed, the oven will beep and the display will show the Timer has finished.

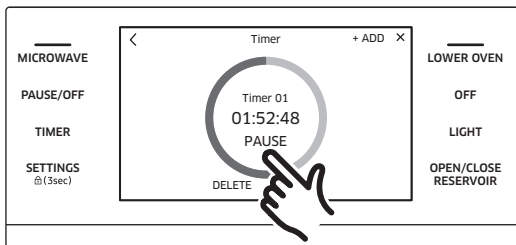

- You can pause, reset, or delete the timer at any time by tapping the screen.

NOTE

After you have performed Steps 1 to 5, you can return to Step 2 and set additional timers. You can also name timers so you can identify them separately. See below.

How to change the timer name

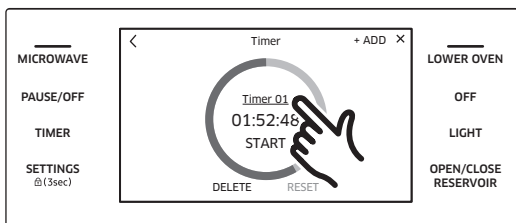

You can change the timer name to identify what you are timing, for example, a chicken defrosting.

- Tap the timer name.
 - The keyboard appears.
- Enter the new timer name, and then tap **OK**.
 - The display shows the changed timer name.

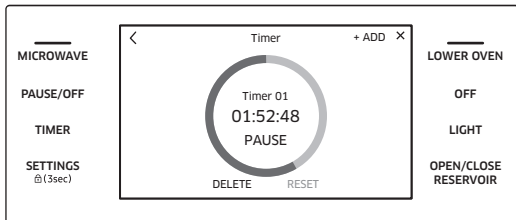
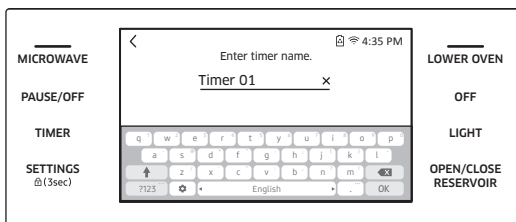

Basic operations

Minimum and maximum settings

Upper microwave oven

All the features listed in the table below have minimum and maximum time, temperatures, and power-level settings.

Tap **MICROWAVE** to select the cooking mode. Set the temperature or microwave power level using the numeric pad. See Basic baking and broiling instructions starting on page 93.

| Feature | | Temp./ Power range | Default Temp./ Power | Max. time |
|-------------|--|--|-------------------------|---------------|
| Manual mode | Microwave | 10-100% | 100% | 1 Hr. 30 min. |
| | | The microwave energy enables food to be cooked or reheated without changing either the form or the color. | | |
| | Convection Sear | 100-450 °F (40-230 °C) | 350 °F | 2 Hr. |
| | | Convection Sear is similar to Convection mode. However, the heating elements generate stronger heat and distribute stronger air currents inside the oven. This is designed to cook food faster while keeping or improving the taste. | | |
| | Broil | - | - | 1 Hr. 30 min. |
| | | Use this for grilling food such as meat. | | |
| | Speed Conv.Sear | 100-450 °F (40-230 °C) 10-70% | 350 °F 30% | 1 Hr. 30 min. |
| | | The heating elements generate heat and the convection fan distributes the heat inside the oven, which is reinforced by microwave energy. | | |
| Speed Broil | 10-70% | 30% | 1 Hr. 30 min. | |
| | The heating elements generate heat, which is reinforced by microwave energy. | | | |

| Feature | | Temp./ Power range | Default Temp./ Power | Max. time |
|-----------|-----------------------|--|-------------------------|-----------|
| Auto mode | Sense Cook™ | The 16 Sensor Cooking features provide pre-programmed cooking times. You do not need to set either the cooking times or the power levels. | | |
| | Conv.Sear AutoCook | To accommodate first-time users of the Power Convection mode, the oven offers 20 auto programs. | | |
| | Healthy Fry | You do not need to set either the cooking time or power level. You can adjust the Healthy fry cook category as shown in this manual (see page 55). You will use less oil compared to frying with an oil fryer. | | |
| | Defrost | The oven offers 4 defrosting programs. | | |
| | Healthy Choice | The Healthy Choice menu contains pre-set cooking programs for 38 different items. You do not need to set the cooking times or the power levels. | | |
| | Auto Cook | For cooking beginners, the oven offers a total of 70 auto cooking programs. | | |
| | Soften/Melt | The oven offers 8 Soften/Melt programs. | | |

Microwave oven (Upper Oven)

Setting the power level

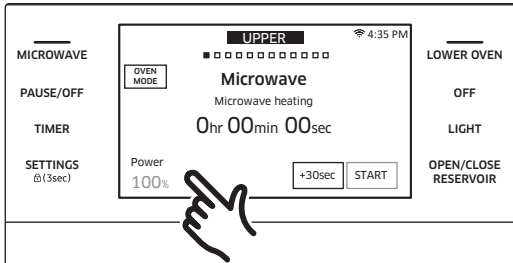

- Tap the **Power Level** area.
- Slide the screen or tap the wheel picker to set the power level. If you tap the wheel picker, the numeric pad will appear.

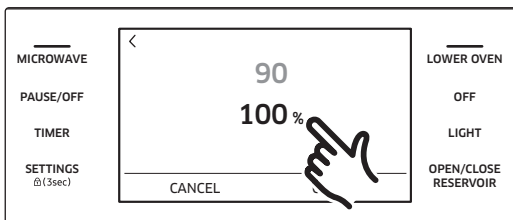

Timed cooking

In timed cooking mode, the oven turns on immediately and cooks for the length of time you select.

At the end of the cooking time, the oven turns off automatically.

- You can use the timed cooking feature only with another cooking operation. (Microwave, Convection Sear, Broil, Speed Conv.Sear, Speed Broil).

How to set the oven for timed cooking

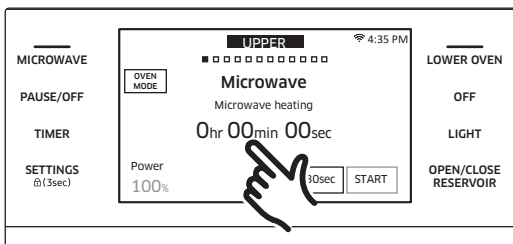

1. Tap **MICROWAVE** to select the cooking operation you want.
2. Tap **Cook Time**. The display will change to the cooking time screen.

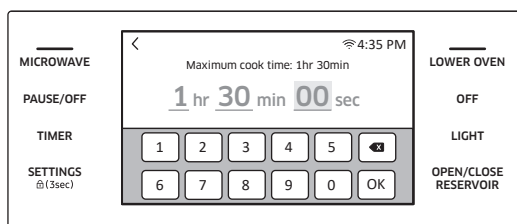

3. Tap numbers in the numeric pad to set the cooking time.

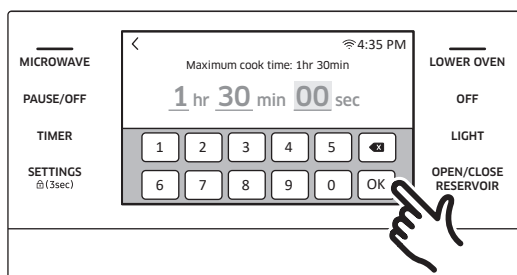

4. Tap **OK**. The cooking time screen closes.

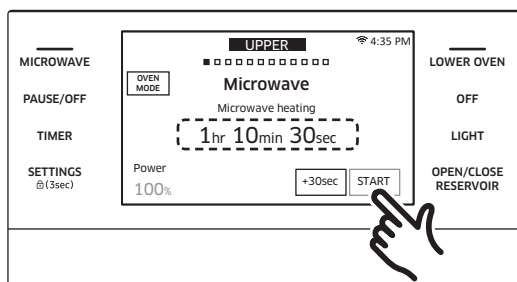

- 5. The cooking time is displayed in the **Cook Time** area on the screen.
- 6. Tap **START** to start cooking.
- 7. If you want to pause cooking, tap **PAUSE**. In **PAUSE**, you can cancel or continue cooking by tapping **OFF** or **CONTINUE**.

NOTE

See pages 93 through 95 for basic baking and broiling instructions.

CAUTION

Use caution with the timed cooking features. You can use these features to cook cured or frozen meats and most fruits and vegetables. For food that can easily spoil, such as milk, eggs, and thawed or fresh fish, meat, or poultry, chill them in the refrigerator first. Even when chilled, they should not stand in the oven for more than 1 hour before cooking begins, and should be removed promptly when cooking is completed. Eating spoiled food can result in sickness from food poisoning.

Microwave oven (Upper Oven)

Microwave

Microwaves are high-frequency electromagnetic waves that can be used to cook or reheat food without changing either the form or color of the food.

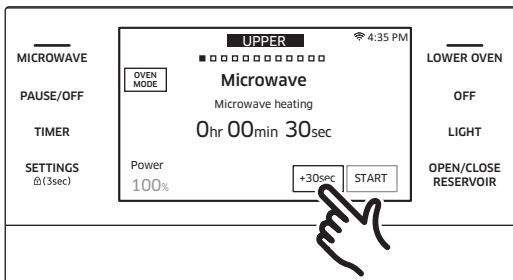
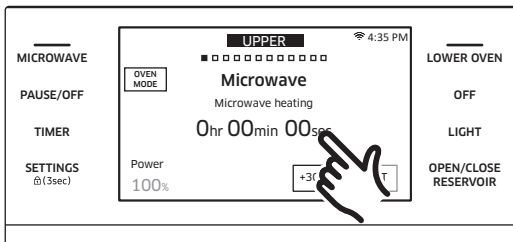
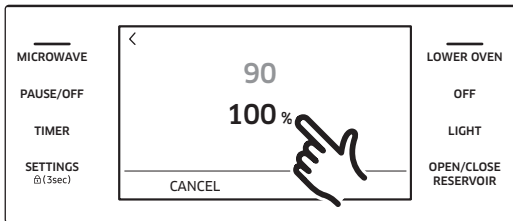
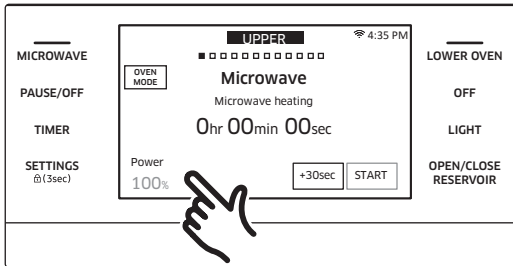

1. Put food in a microwave-safe container, and then place the container in the center of the optitray. Close the door.
2. Tap **MICROWAVE** and swipe the screen to select **Microwave**.
3. Tap **Power Level**, and then, slide the screen or tap the wheel picker to set the power level. If you tap the wheel picker, the numeric pad will appear.
4. Tap **Cook Time**, and then use the number pad to input a desired cook time. You can also use the **+30sec** button to specify the cooking time.

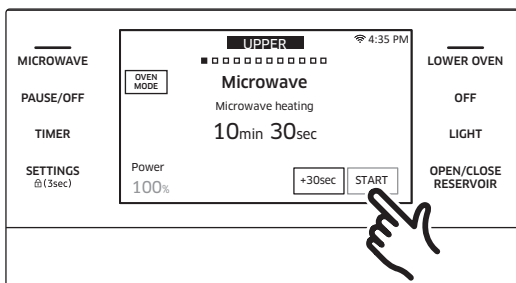

5. Tap **START** to start cooking.
6. If you want to pause cooking, tap **PAUSE**. In **PAUSE**, you can cancel or continue cooking by tapping **OFF** or **CONTINUE**.

⚠ CAUTION

- Use only microwave-safe cookware.
- Use oven mitts when taking out food.

Power level

| | | | |
|------|---------------|-----|--------------|
| 100% | (High) | 50% | (Medium) |
| 90% | (Sauté) | 40% | (Medium low) |
| 80% | (Reheat) | 30% | (Low) |
| 70% | (Medium high) | 20% | (Defrost) |
| 60% | (Simmer) | 10% | (Warm) |

Microwave oven (Upper Oven)

Convection Sear

The heating elements generate heat, which is evenly distributed inside the oven by the convection fan. You can use a microwave rack or a combination of a rack and even plate on the optitray. Use this mode for biscuits, individual scones, rolls, and cakes as well as fruit cakes, choux pastries, and soufflés.

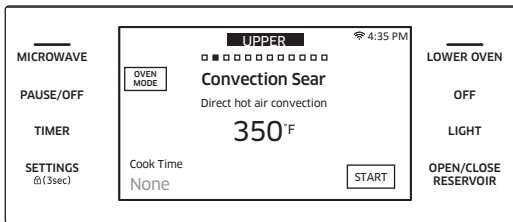

1. Put a rack or the combination of a rack and the even plate on the optitray.
2. Tap **MICROWAVE** and swipe the screen to select **Convection Sear**, and then tap the temperature area. The numeric pad will appear. You can input a desired temperature from 100 °F to 450 °F (default: 350 °F).

NOTE

To preheat, simply tap **START**.

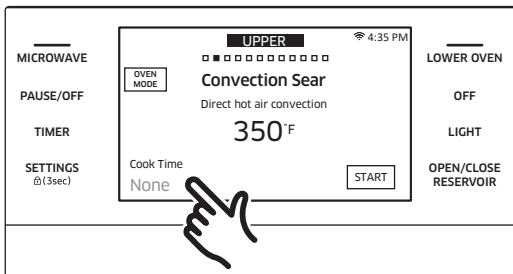

3. Tap **Cook Time**, and then use the number pad to specify a cooking time.

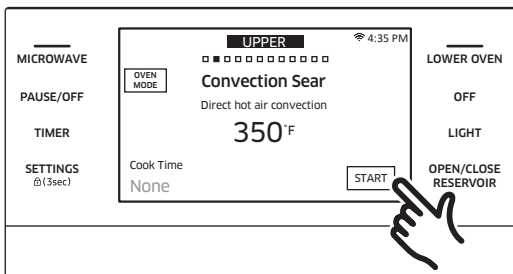

4. Tap **START** to start cooking.
5. If you want to pause cooking, tap **PAUSE**. In **PAUSE**, you can cancel or continue cooking by tapping **OFF** or **CONTINUE**.

CAUTION

- Use only microwave-safe cookware.
- Use oven mitts when taking out food.

Broil

For best performance, make sure all heating elements are in the horizontal position.

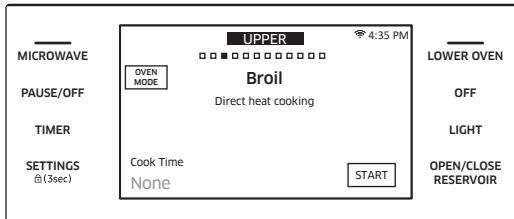

1. Put a rack or the combination of a rack and the even plate on the optitray.
2. Tap **MICROWAVE** and swipe the screen to select **Broil**. If preheating is preferred, simply tap **START**.

NOTE

You cannot set the temperature in **Broil** mode.

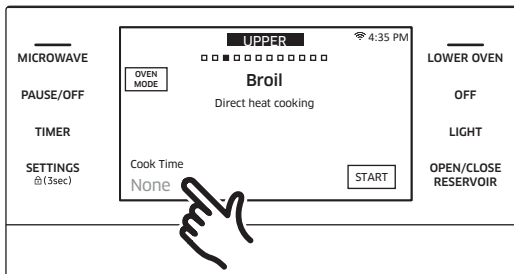

3. Tap **Cook Time**, and then use the number pad to specify a cooking time.

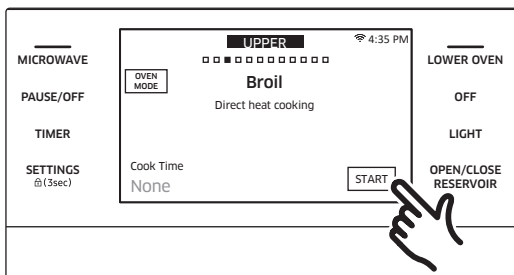

4. Tap **START** to start cooking.
5. If you want to pause cooking, tap **PAUSE**. In **PAUSE**, you can cancel or continue cooking by tapping **OFF** or **CONTINUE**.

CAUTION

- Use only microwave-safe cookware.
- Use oven gloves when taking out food.

Microwave oven (Upper Oven)

Speed Conv.Sear

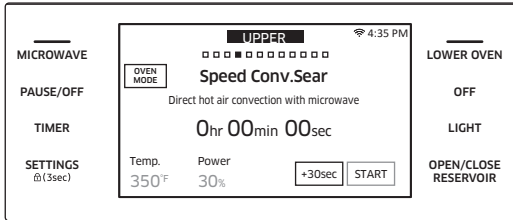

1. Put a rack or the combination of a rack and the even plate on the optitray.
2. Tap **MICROWAVE** and swipe the screen to select **Speed Conv.Sear**, and then tap the temperature area. The numeric pad will appear. You can input a desired temperature from 100 °F to 450 °F (default: 350 °F).

NOTE

To preheat, simply tap **START**.

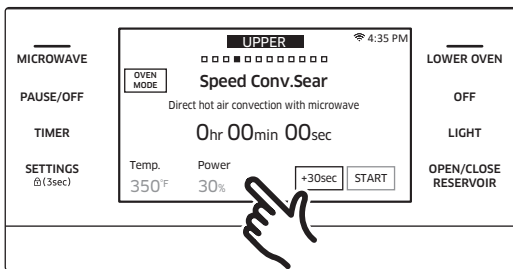

3. Tap **Power Level**, and then slide the screen or tap the wheel picker to specify a power level from 10% to 70%. If you tap the wheel picker, the numeric pad appears.

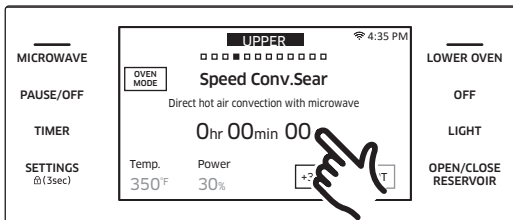

4. Tap **Cook Time**, and then use the number pad to specify a cooking time. You can also use the **+30sec** button to specify the cooking time.

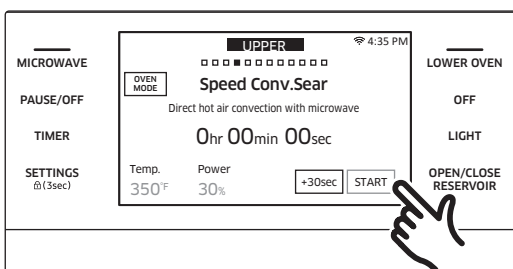

5. Tap **START** to start cooking.
6. If you want to pause cooking, tap **PAUSE**. In **PAUSE**, you can cancel or continue cooking by tapping **OFF** or **CONTINUE**.

⚠ CAUTION

- Use only microwave-safe cookware.
- Use oven gloves when taking out food.

Speed Broil

The heating elements generate heat, which is reinforced by the microwave energy.

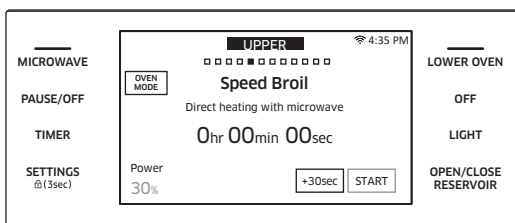

1. Put a rack or the combination of a rack and the even plate on the optitray.
2. Tap **MICROWAVE** and swipe the screen to select **Speed Broil**.

NOTE

You cannot set the temperature in Speed broil mode.

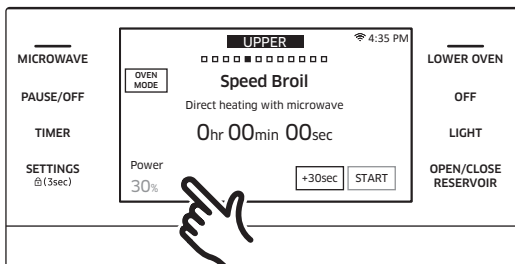

3. Tap **Power Level**, and then slide the screen or tap the wheel picker to specify a power level from 10% to 70%. If you tap the wheel picker, the numeric pad appears.

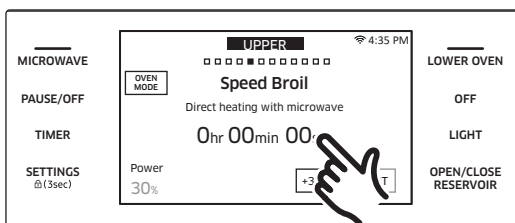

4. Tap **Cook Time**, and then use the number pad to specify a cooking time. You can also use the **+30sec** button to specify the cooking time.

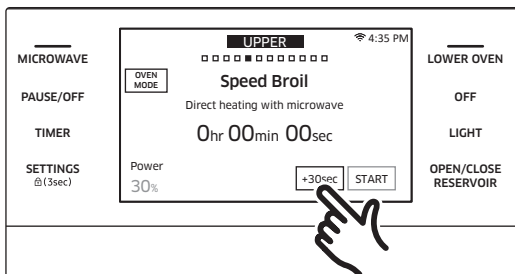

Microwave oven (Upper Oven)

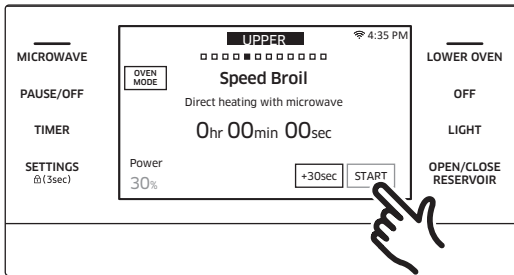

5. Tap **START** to start cooking.
6. If you want to pause cooking, tap **PAUSE**. In **PAUSE**, you can cancel or continue cooking by tapping **OFF** or **CONTINUE**.

⚠ CAUTION

- Use only microwave-safe cookware.
- Use oven gloves when taking out food.

Sense Cook™

The oven offers 16 different Sense Cook™ options, which include pre-programmed cooking times. You do not need to set either the cooking time or the power level. Once you have selected a program and touched **START**, the oven automatically sets the cooking time and starts to cook. The gas-sensing animation effect shows the status of the sensing process.

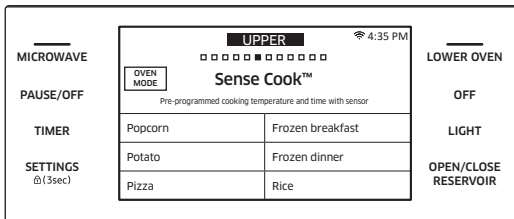

1. Put the food in the center of the optitray and close the door.
2. Tap **MICROWAVE** and swipe the screen to select **Sense Cook™**. The display will show 16 Sense Cook™ options. (You can scroll down through the list.)
3. Tap the **Sense Cook™** option you want.

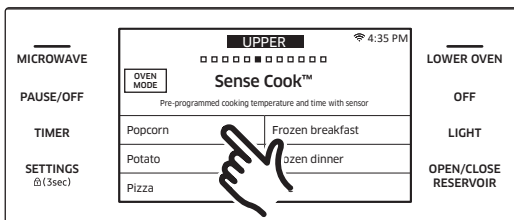

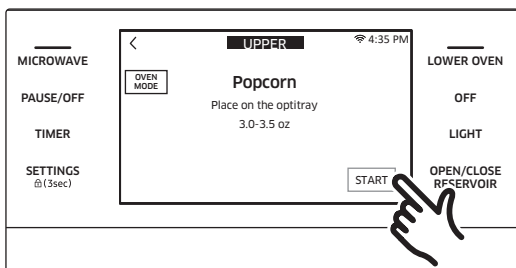

4. Tap **START** to start cooking.
5. If you want to pause cooking, tap **PAUSE**. In **PAUSE**, you can cancel or continue cooking by tapping **OFF** or **CONTINUE**.

CAUTION

- Use only microwave-safe cookware.
- Use oven gloves when taking out food.

| Food | Amount | Instructions |
|----------|-------------------------|---|
| Popcorn | 3.0-3.5 oz 1 package | Use only one microwave popcorn bag at a time. Be careful when removing the heated bag from the oven and when opening it. |
| Potato | 1 to 5 ea | Pierce each potato several times with a fork. Place on the optitray in a spoke-like fashion. After cooking, let the potatoes stand for 3-5 minutes. Let the oven cool for at least 5 minutes before using it again. |
| Pizza | 1 to 4 slices | Place 1-4 pizza slices on a microwave-safe plate with the wide ends of the slices towards the outside edge of the plate. Do not let the slices overlap. Do not cover. Let the oven cool for at least 5 minutes before using it again. |
| Beverage | 6 to 8 oz | Use a measuring cup or mug and do not cover. Place the beverage in the oven. After heating, stir well. Let the oven cool for at least 5 minutes before using it again. |

Microwave oven (Upper Oven)

| Food | Amount | Instructions |
|--------------|-----------------|--|
| Dinner Plate | 1 serving | <p>Use only precooked, refrigerated foods. Cover the plate with vented (1 inch vent) plastic wrap or waxed paper tucked under the plate. If the food is not as hot as you would like after using the “Sensor” function, continue heating using additional time and power.</p> <p>Contents: 3-4 oz meat, poultry, or fish (up to 6 oz with bone) ½ cup starch (potatoes, pasta, rice, etc.) ½ cup vegetables (about 3-4 oz)</p> |
| Casserole | 1 to 4 servings | <p>Cover the plate with vented (1 inch vent) plastic wrap. If the food is not as hot as you would like after using the “Sensor” function, continue heating using additional time and power. Stir the food once before serving.</p> <p>Contents: Casseroles: refrigerated</p> |
| Pasta | 1 to 4 servings | <p>Cover the plate with vented (1 inch vent) plastic wrap. If the food is not as hot as you would like after using the “Sensor” function, continue heating using additional time and power. Stir the food once before serving.</p> <p>Contents: Pasta: canned spaghetti</p> |
| Soup | 1 to 4 servings | <p>Cover the bowl with vented (1 inch vent) plastic wrap. If the soup is not as hot as you would like after using the “Sensor” function, continue heating using additional time and power. Stir the soup once before serving.</p> <p>Contents: Soup: refrigerated</p> |

Microwave oven (Upper Oven)

| Food | Amount | Instructions |
|-----------------------|-----------------|--|
| Frozen Breakfast | 4 to 8 oz | Use this button for frozen sandwiches, breakfast entrees, pancakes, waffles, etc. Follow the package instructions for covering and standing. Let the oven cool for at least 5 minutes before using it again. |
| Frozen Dinner | 13 to 18 oz | Remove the food from its wrapping and follow the instructions on the box for covering and letting stand. Let the oven cool for at least 5 minutes before using it again. |
| Rice | 1 to 2 cups | Add 1 cup of cold water for 1 cup of rice. Use a large glass pyrex bowl. Cover with vented (1 inch vent) plastic wrap. Rice doubles in volume during cooking. After the cooking time is over, stir before standing time, and then salt or add herbs and butter. |
| Mini Ravioli | 8 to 14 oz | Put mini ravioli evenly into a microwave safe glass bowl. Cover with vented (1 inch vent) plastic wrap. Let stand for 2-3 minutes. Stir the food once before serving. |
| Fresh Vegetables | 1 to 4 servings | Place the fresh vegetables (broccoli florets, cauliflower florets, zucchini, Eggplants etc.) in a microwave-safe ceramic, glass, or plastic dish and add 2-4 tbs. water. Cover with vented (1 inch vent) plastic wrap while cooking and stir before letting stand. Let the oven cool for at least 5 minutes before using it again. |
| Fresh Root Vegetables | 1 to 4 servings | Place the fresh vegetables (carrots, leeks, potatoes, beet etc.) in a microwave-safe ceramic, glass, or plastic dish and add 2-4 tbs. water. Cover with vented (1 inch vent) plastic wrap while cooking and stir before letting stand. Let the oven cool for at least 5 minutes before using it again. |

Microwave oven (Upper Oven)

| Food | Amount | Instructions |
|-------------------|-----------------|--|
| Frozen Vegetables | 1 to 4 servings | Place the frozen vegetables in a microwave-safe ceramic, glass, or plastic dish and add 2-4 tbs. water. Cover with vented (1 inch vent) plastic wrap to cook. Stir before letting stand for 3-5 minutes. Let the oven cool for at least 5 minutes before using it again. |
| Canned Vegetables | 1 to 4 servings | Place the canned vegetables in a microwave-safe ceramic, glass, or plastic dish. Cover with vented (1 inch vent) plastic wrap while cooking and stir before letting stand. Let the oven cool for at least 5 minutes before using it again. |

Auto sensor cooking instructions

The Auto Sensor cooks your food automatically by detecting the amount of gas generated by the food while it cooks.

- When food is cooked, many kinds of gas are generated. The Auto Sensor determines the proper time and power level by detecting these gases, eliminating the need to set the cooking time and power level.
- When you cover a container with its lid or plastic wrap during Sensor Cooking, the Auto Sensor will detect the gases generated after the container has been saturated with steam.

NOTE

If using cling film or plastic wrap, leave a small opening (vent) near the edge of the dish for ventilation or pierce the plastic with a knife or fork in several places.

- Shortly before cooking ends, the remaining cooking time will begin its count down. This will be a good time for you to rotate or stir the food for even cooking if it is necessary.
- Before Auto Sensor cooking, food may be seasoned with herbs, spices, or browning sauces. A word of caution though: Salt or sugar may cause burn spots on food so these ingredients should be added after cooking.

Utensils & cover

- To obtain good cooking results with the Auto Sensor function, follow the directions for selecting appropriate containers and covers in the charts in this manual.
- Always use microwave-safe containers and cover them with their lids or with plastic wrap. When using plastic wrap, turn back one corner to allow steam to escape at the proper rate.
- Always cover your microwave-safe dish or container with its matching lid. If the dish or container does not have its own lid, use plastic wrap.
- Fill containers at least half full.
- Foods that require stirring or rotating should be stirred or turned toward the end of the Sense Cook cycle, after the time has started to count down on the display.

CAUTION

- After installing the oven and plugging it into an electrical outlet, do not unplug the power cord for 24 hours. The gas sensor needs time to stabilize in order to cook satisfactorily.
- It is not advisable to use the Auto Sensor cooking feature continuously. i.e. one cooking operation immediately after another.
- Install the oven in a well ventilated location for proper cooling and airflow and to ensure the sensor will operate accurately.
- To avoid poor results, do not use the Auto Sensor cooking function when the room ambient temperature is above 90 °F or below 45 °F.
- Do not use volatile detergent to clean your oven. Gas resulting from this detergent may affect the sensor.
- Avoid placing the oven near high moisture or gas-emitting appliances, since this will interfere with the proper performance of the Auto Sensor.
- Always keep the inside of the oven clean. Wipe all spills with a damp cloth. This oven is designed for household use only.

Microwave oven (Upper Oven)

Conv.Sear AutoCook

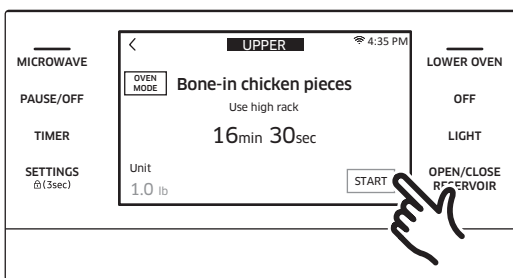
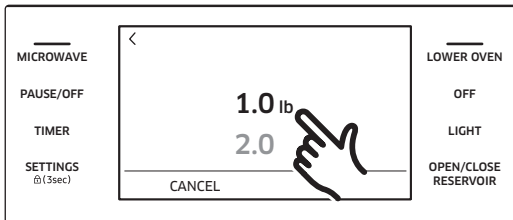
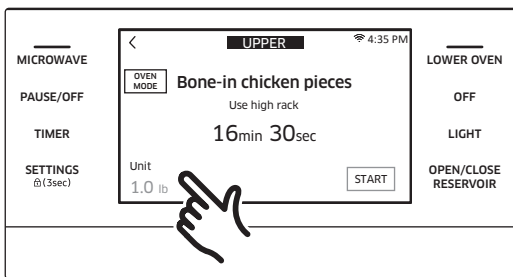
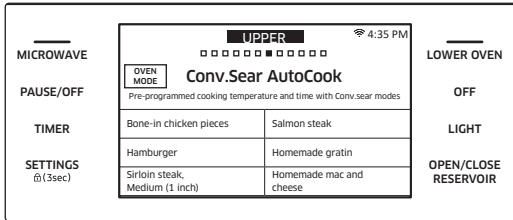

1. Put the food in the center of the optitray and close the door.
2. Tap **MICROWAVE** and swipe the screen to select **Conv.Sear AutoCook**.
3. Tap to select one of 20 different options.
4. Tap the weight area to select the food weight screen.
5. Slide the screen to select the food weight.
6. Tap **START** to start cooking.
7. If you want to pause cooking, tap **PAUSE**. In **PAUSE**, you can cancel or continue cooking by tapping **OFF** or **CONTINUE**.

CAUTION

- Use only microwave-safe cookware.
- Use oven gloves when taking out food.

Microwave oven (Upper Oven)

| Food | Amount | Instructions |
|--------------------------------------|-----------------------------------|--|
| Bone-in chicken pieces | 1.0 lb 2.0 lbs | Brush the chicken pieces with oil and seasonings. Place the pieces skin side down on the high rack. When the microwave beeps, turn over bone-in chicken pieces, and then press START to continue. |
| Hamburger | 2 ea 4 ea (1 ea = 4 oz) | Place the hamburgers on the even plate. Place the plate on the high rack. When the microwave beeps, turn the hamburgers over, and then press START to continue. |
| Sirloin steak, Medium (1 inch) | 1 inch 1.0 lb | Brush the Steaks with oil and seasonings. Place the steak on the high rack. When the microwave beeps, turn over the steak, and then press START to continue. Let the steak rest for 5 minutes before slicing. |
| Sirloin steak, Well Done (1 inch) | 1 inch 1.0 lb | Brush the Steaks with oil and seasonings. Place the steak on the high rack. When the microwave beeps, turn over the steak, and then press START to continue. Let the steak rest for 5 minutes before slicing. |
| Tenderloin steak, Medium (1 inch) | 1 inch 2 ea (1 ea = 1/2 lb) | Brush the Steaks with oil and seasonings. Place the steak on the high rack. When the microwave beeps, turn over the steak and then press START to continue. Let the steak rest for 5 minutes before slicing. |
| Tenderloin steak, Well Done (1 inch) | 1 inch 2 ea (1 ea = 1/2 lb) | Brush the Steaks with oil and seasonings. Place the steak on the high rack. When the microwave beeps, turn over the steak and then press START to continue. Let the steak rest for 5 minutes before slicing. |
| T-bone steak, Medium (1 inch) | 1 inch 1.5 lbs | Brush the Steaks with oil and seasonings. Place the steak on the high rack. When the microwave beeps, turn over the steak and then press START to continue. Let the steak rest for 5 minutes before slicing. |

Microwave oven (Upper Oven)

| Food | Amount | Instructions |
|----------------------------------|---------------------------------|--|
| T-bone steak, Well Done (1 inch) | 1 inch 1.5 lbs | Brush the Steaks with oil and seasonings. Place the steak on the high rack. When the microwave beeps, turn over the steak and then press START to continue. Let the steak rest for 5 minutes before slicing. |
| Barbecue pork ribs | 1.0 lb 2.0 lbs | Brush the pork ribs with barbecue sauce. Place the pork ribs on the low rack. |
| Boneless pork chops | 2 ea 4 ea (1 ea = 5-6 oz) | Brush the pork chops with oil and seasonings. Place the pork chops on the high rack. When the microwave beeps, turn over the pork chops, and then press START to continue. |
| Salmon steak | 2 ea 4 ea (1 ea = 5-6 oz) | Brush the Salmon fillets with oil and seasonings. Place the Salmon fillets on the even plate, and then place the plate on the high rack. |
| Homemade gratin | 20 oz 40 oz | <p>Ingredients (40 oz) 25 oz potatoes, 4 oz milk, 4 oz cream, 1 oz beaten whole egg, 1 tsp each of salt, pepper, nutmeg, 5-6 oz grated mozzarella cheese, butter, thyme.</p> <p>For a 20 oz recipe, use half the quantities above.</p> <p>Method Peel potatoes and slice them to 1/8-1/4 inch thickness. Spread the slices on a clean towel and keep them covered with the towel while you prepare the rest of the ingredients. Rub the surface of a gratin dish with the butter. Put the rest of the ingredients except grated cheese into a large bowl and stir well. Layer the potato slices in the dish slightly overlapping and pour the mixture over the potatoes. Spread the grated cheese over the top, and then put the gratin dish on the low rack. After cooking, let stand for 2-3 minutes. Serve sprinkled with a few fresh thyme leaves.</p> |

Microwave oven (Upper Oven)

| Food | Amount | Instructions |
|-------------------------|----------------|--|
| Homemade mac and cheese | 12 oz | Put oven dish on the low rack and cook. |
| Frozen pizza (6 inch) | 6 inch | Place the pizza on the high rack. |
| Frozen pizza (12 inch) | 12 inch | Place the pizza on the low rack. |
| Frozen waffles | 2 ea 4 ea | Place the waffles on the even plate, then place the plate on the low rack. |
| Frozen cheese sticks | 6 ea 12 ea | Place the cheese sticks on the even plate, then place the plate on the high rack. |
| Frozen buffalo wings | 12 oz 16 oz | Place the chicken wings on the even plate, then place the plate on the high rack. |
| Frozen potato chips | 12 oz 16 oz | Place the frozen potato chips on the even plate, then place the plate on the high rack. |
| Frozen chicken nuggets | 8 oz 16 oz | Place the frozen chicken nuggets on the even plate, then place the plate on the high rack. |

Healthy Fry

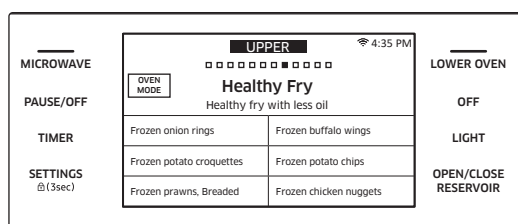

1. Put the food in the center of the optitray, and then close the door.
2. Tap **MICROWAVE** and swipe the screen to select **Healthy Fry**.
3. Tap to select one of 14 different options.
4. Tap the weight area to select the food weight screen.



Microwave oven (Upper Oven)

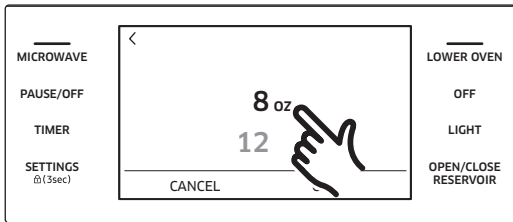

5. Slide the screen to select the food weight.

6. Tap OK.

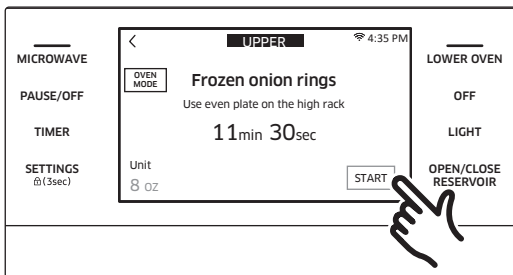

7. Tap **START** to start cooking.

8. If you want to pause cooking, tap **PAUSE**. In **PAUSE**, you can cancel or continue cooking by tapping **OFF** or **CONTINUE**.

CAUTION

- Use only microwave-safe cookware.
- Use oven gloves when taking out food.

| Food | Amount | Instructions |
|--------------------------|----------------|--|
| Frozen onion rings | 8 oz 12 oz | Place the onion rings on the even plate, then place the plate on the high rack. |
| Frozen potato croquettes | 8 oz 16 oz | Place frozen potato croquettes on the even plate, then place the plate on the high rack. |
| Frozen prawns, breaded | 8 oz 12 oz | Place frozen prawns on the even plate, then place the plate on the high rack. |
| Frozen mini spring rolls | 8 oz 12 oz | Place frozen mini spring rolls on the even plate, then place the plate on the high rack. |
| Frozen potato wedges | 12 oz 16 oz | Place frozen potato wedges on the even plate, then place the plate on the high rack. |
| Frozen fish cutlets | 8 oz 12 oz | Place frozen fish cutlets on the even plate, then place the plate on the high rack. |
| Frozen cheese sticks | 6 ea 12 ea | Place the cheese sticks on the even plate, then place the plate on the high rack. |
| Frozen buffalo wings | 12 oz 16 oz | Place the chicken wings on the even plate, then place the plate on the high rack. |

| Food | Amount | Instructions |
|------------------------|----------------|---|
| Frozen potato chips | 12 oz 16 oz | Place the frozen potato chips on the even plate, then place the plate on the high rack. |
| Frozen chicken nuggets | 8 oz 16 oz | Place the frozen chicken nuggets on the even plate, then place the plate on the high rack. |
| Homemade french fries | 8 oz 12 oz | Peel potatoes and cut into sticks with a thickness of 7/16" x 7/16" (10 x 10 mm). Soak in cold water for 30-40 minutes. (Put some salt in the cold water.) Dry potato sticks with a towel, and then brush with 1 tsp (5 g) oil. (Try to remove the moisture completely. Otherwise, the potatoes may get scorched and stick to the bottom of the tray.) Place them on the even plate, then place the plate on the high rack. |
| Drumsticks | 3 ea 6 ea | Rinse drumsticks and place them on the even plate, then place the plate on the high rack. When the microwave beeps, turn over drumsticks, and then press START to continue. |
| Chicken wings | 10 ea 20 ea | Rinse chicken wings and place on the even plate, then place the plate on the high rack. |
| Roasted vegetables | 8 oz 12 oz | Cut eggplants, carrots, zucchini, and then brush them with 1 tsp (5 g) oil. Place sliced vegetables on the even plate, then place the plate on the high rack. |

Microwave oven (Upper Oven)

Defrost

The oven provides 4 different defrosting options. The time and power levels are automatically adjusted according to your selection.

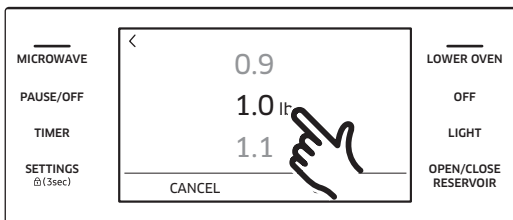
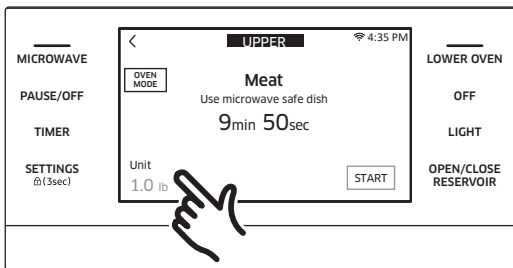
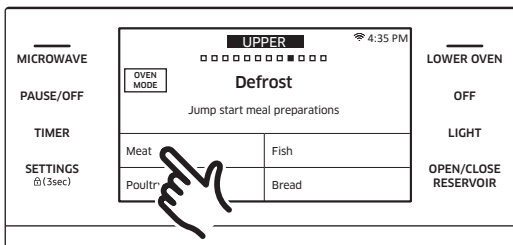
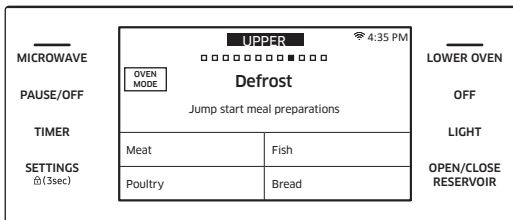

1. Put food in suitable cookware, then put the cookware on the optitray and close the door.
2. Tap **MICROWAVE** and swipe the screen to select **Defrost**. The display will show 4 defrost options.
3. Tap the **Defrost** option you want.
4. Tap the weight area to select the food weight.
5. Slide the screen or tap the number to select the food weight. If you tap the number, the numeric pad appears.
6. Tap **OK**.

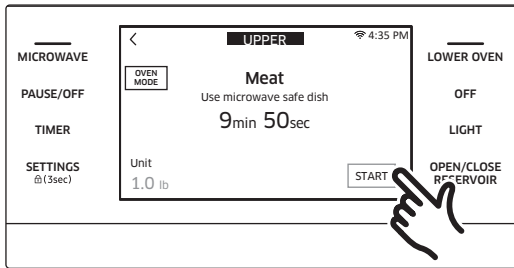

7. Tap **START** to start defrosting.
8. If you want to pause defrosting, tap **PAUSE**. In **PAUSE**, you can cancel or continue defrosting by tapping **OFF** or **CONTINUE**.

⚠ CAUTION

- Use only microwave-safe cookware.
- Use oven gloves when taking out food.

| Food | Amount | Instructions |
|---------|-------------|--|
| Meat | 0.1-3.5 lbs | Shield the edges with aluminium foil. Turn the meat over when the oven beeps. This program is suitable for lamb, pork, steaks, chops, and ground meat. For ground meat, place the meat directly on the optitray tray on wax paper. Do not use an extra tray. Let stand, covered with foil, for 5-10 minutes. |
| Poultry | 0.1-3.5 lbs | Shield the leg and wing tips with aluminium foil. Turn the poultry over when the oven beeps. This program is suitable for whole chicken as well as for chicken portions. |
| Fish | 0.1-3.5 lbs | Shield the tail of a whole fish with aluminium foil. Turn the fish over when the oven beeps. This program is suitable for whole fish as well as for fish fillets. |
| Bread | 0.1-2.0 lbs | Place bread on a ceramic plate and if possible, turn over as soon as the oven beeps. This program is suitable for all kinds of bread, sliced or whole, as well as for bread rolls and baguettes. Arrange bread rolls in a circle. |

Microwave oven (Upper Oven)

Healthy Choice

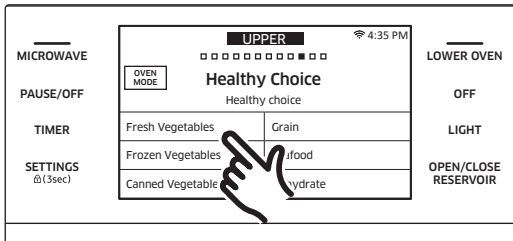

1. Put the food in the center of the optitray and close the door.
2. Tap **MICROWAVE** and swipe the screen to select **Healthy Choice**.

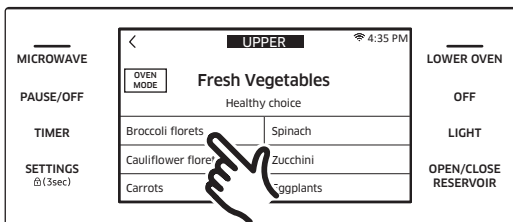

3. Tap to select **Healthy Choice** cook. The display will show 6 different menus. These provide 38 Healthy Choice cook options. (You can scroll down the list.)

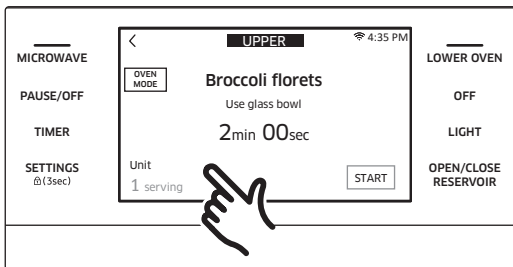

4. Tap the serving area to display the servings of food screen.

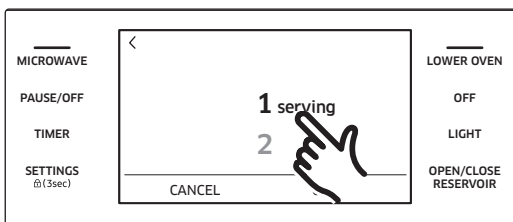

5. Slide the number to select the number of servings.
6. Tap **OK**.

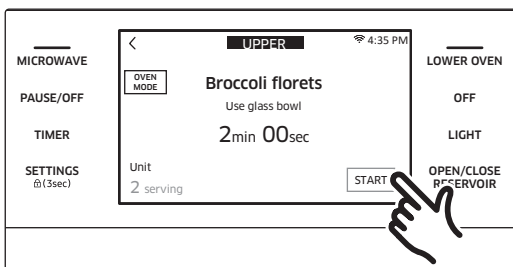

7. Tap **START** to start cooking.
8. If you want to pause cooking, tap **PAUSE**. In **PAUSE**, you can cancel or continue cooking by tapping **OFF** or **CONTINUE**.

⚠ CAUTION

- Use only microwave-safe cookware.
- Use oven gloves when taking out food.

| Food | Amount | Instructions |
|----------------------------|---|---|
| Fresh Vegetables | | |
| Broccoli florets | 1 serving 2 servings 3 servings 4 servings (1 serving = 4-5 oz) | Wash and clean the broccoli. Prepare the florets and place in a microwave-safe bowl. Add 1-4 tablespoons of water (1 Tbsp per serving). Cover during cooking and stir afterwards. |
| Cauliflower florets | 1 serving 2 servings 3 servings 4 servings (1 serving = 4-5 oz) | Wash and clean the cauliflower. Prepare the florets and place in a microwave-safe bowl. Add 1-4 tablespoons of water (1 Tbsp per serving). Cover during cooking and stir afterwards. |
| Carrots | 1 serving 2 servings 3 servings 4 servings (1 serving = 4-5 oz) | Wash and clean the carrots. Cut the carrots into even slices and place in a microwave-safe bowl. Add 1-4 tablespoons of water (1 Tbsp per serving). Cover during cooking and stir afterwards. |
| Green beans | 1 serving 2 servings 3 servings 4 servings (1 serving = 4-5 oz) | Wash and clean the green beans. Place the green beans in a microwave-safe bowl. Add 1-4 tablespoons of water (1 Tbsp per serving). Cover during cooking and stir afterwards. |
| Spinach | 1 serving 2 servings 3 servings 4 servings (1 serving = 4-5 oz) | Wash and clean the spinach. Place the spinach in a microwave-safe bowl. Add 1-4 tablespoons of water (1 Tbsp per serving). Cover during cooking and stir afterwards. |

Microwave oven (Upper Oven)

| Food | Amount | Instructions |
|--------------------------|---|--|
| Zucchini | 1 serving 2 servings 3 servings 4 servings (1 serving = 4-5 oz) | Wash and clean the zucchini. Cut zucchini into slices. Place the zucchini in a microwave-safe bowl. Add 1-4 tablespoons of water (1 Tbsp per serving). Cover during cooking and stir afterwards. |
| Eggplants | 1 serving 2 servings 3 servings 4 servings (1 serving = 4-5 oz) | Wash and clean the eggplant. Cut eggplant into slices. Place the eggplant in a microwave-safe bowl and sprinkle with 1 Tbsp lemon juice. Add 1-4 tablespoons of water (1 Tbsp per serving). Cover during cooking and stir afterwards. |
| Potatoes | 1 ea 2 ea 3 ea 4 ea | Pierce each potato several times with a fork. Place on the optitray in a spoke-like fashion. After cooking, let the potatoes stand for 3-5 minutes. |
| Frozen Vegetables | | |
| Broccoli florets | 1 serving 2 servings 3 servings 4 servings (1 serving = 4-5 oz) | Place the broccoli in a microwave-safe bowl. Add 1-4 tablespoons of water (1 Tbsp per serving). Cover during cooking and stir afterwards. |
| Carrots | 1 serving 2 servings 3 servings 4 servings (1 serving = 4-5 oz) | Place the carrots in a microwave-safe bowl. Add 1-4 tablespoons of water (1 Tbsp per serving). Cover during cooking and stir afterwards. |
| Corn | 1 serving 2 servings 3 servings 4 servings (1 serving = 3-4 oz) | Place the corn in a microwave-safe bowl. Add 1-4 tablespoons of water (1 Tbsp per serving). Cover during cooking and stir afterwards. |

Microwave oven (Upper Oven)

| Food | Amount | Instructions |
|--------------------------|---|---|
| Green beans | 1 serving 2 servings 3 servings 4 servings (1 serving = 4-5 oz) | Place the green beans in a microwave-safe bowl. Add 1-4 tablespoons of water (1 Tbsp per serving). Cover during cooking and stir afterwards. |
| Peas | 1 serving 2 servings 3 servings 4 servings (1 serving = 3-4 oz) | Place the peas in a microwave safe bowl. Add 1-4 tablespoons of water (1 Tbsp per serving). Cover during cooking and stir afterwards. |
| Mixed vegetables | 1 serving 2 servings 3 servings 4 servings (1 serving = 4-5 oz) | Place the mixed vegetables in a microwave-safe bowl. Add 1-4 tablespoons of water (1 Tbsp per serving). Cover during cooking and stir afterwards. |
| Canned Vegetables | | |
| Carrots | 1 serving 2 servings 3 servings 4 servings (1 serving = 4-5 oz) | Place the carrots in a microwave-safe bowl. Cover during cooking and stir afterwards. |
| Corn | 1 serving 2 servings 3 servings 4 servings (1 serving = 3-4 oz) | Place the corn in a microwave-safe bowl. Cover during cooking and stir afterwards. |
| Green beans | 1 serving 2 servings 3 servings 4 servings (1 serving = 4-5 oz) | Place the green beans in a microwave-safe bowl. Cover during cooking and stir afterwards. |

Microwave oven (Upper Oven)

| Food | Amount | Instructions |
|--------------|---|---|
| Peas | 1 serving 2 servings 3 servings 4 servings (1 serving = 3-4 oz) | Place the peas in a microwave-safe bowl. Cover during cooking and stir afterwards. |
| Spinach | 1 serving 2 servings 3 servings 4 servings (1 serving = 4-5 oz) | Place the spinach in a microwave-safe bowl. Cover during cooking and stir afterwards. |
| Beans | 1 serving 2 servings 3 servings 4 servings (1 serving = 4-5 oz) | Place the beans in a microwave-safe bowl. Cover during cooking and stir afterwards. |
| Grain | | |
| Oatmeal | 1 pack 2 packs | Follow the package directions for the recommended amount of water needed. Stir well before cooking and afterwards. |
| Brown rice | 1 cup 2 cups | Add 1 cup of cold water for 1 cup of rice. Use a large glass bowl. Cover with vented (1 inch vent) plastic wrap. Rice doubles in volume during cooking. After the cooking time is over, stir before standing time, and then salt or add herbs and butter. |
| White rice | 1 cup 2 cups | Add 1 cup of cold water for 1 cup of rice. Use a large glass bowl. Cover with vented (1 inch vent) plastic wrap. Rice doubles in volume during cooking. After the cooking time is over, stir before standing time, and then salt or add herbs and butter. |
| Bulgur | ½ cup 1 cup | Follow the package directions for the recommended amount of water needed. Stir well before cooking and fluff with a fork afterwards. |

| Food | Amount | Instructions |
|----------------------|---------------------------------|--|
| Quinoa | 1 cup 2 cups | Follow the package directions for the recommended amount of water needed. Stir well before cooking and afterwards. |
| Whole wheat macaroni | 1 cup 2 cups | Follow the package directions for the recommended amount of water needed. Carefully remove from the microwave and drain the hot water. |
| Whole wheat couscous | 1 cup 2 cups | Follow the package directions for the recommended amount of water needed. Carefully remove from the microwave and drain the hot water. |
| Seafood | | |
| White fish fillet | 1 ea 2 ea | Place the fillets (cod, pollack, etc.) on the even plate, then place the plate on the high rack. Let stand for 1-2 minutes. |
| Salmon fillet | 2 ea 4 ea (1ea = 5-6 oz) | Brush the Salmon fillets with oil and seasonings. Place the Salmon fillets on the even plate, and then place the plate on the high rack. |
| Tilapia fillet | 2 ea 4 ea (1ea= 5-6 oz) | Brush the Tilapia fillets with oil and seasonings. Place the fillets on the even plate, and then place the plate on the high rack. |
| Tuna steak | 2 ea 4 ea (1 ea = 4-5 oz) | Brush the Tuna steaks with oil and seasonings. Place the steaks on the even plate, and then place the plate on the high rack. |
| Dehydrate | | |
| Dried apple | 1 ea | Wash an apple and slice it in 1/8 - 1/2 inch thickness. Mix sugar and cinnamon together in a bowl. Sprinkle over apple slices. Place the apple slices on the low rack. |
| Dried pineapple | 1/2 ea | Peel a pineapple and slice it in 1/8 - 1/2 inch thickness. Place the pineapple slices on the low rack. |
| Dried banana | 2 ea | Peel bananas and slice them in 1/8 - 1/2 inch thickness. Place the banana slices on the low rack. |

Microwave oven (Upper Oven)

| Food | Amount | Instructions |
|--------------------|--------|---|
| Dried orange | 1 ea | Wash an orange and slice it in 1/8 - 1/2 inch thickness. Place the orange slices on the low rack. |
| Dried lime | 2 ea | Wash limes and slice them in 1/8 - 1/2 inch thickness. Place the lime slices on the low rack. |
| Dried potato | 1 ea | Wash a potato and slice it in 1/8 - 1/2 inch thickness. Sprinkle salt over potato slices. Place the potato slices on the low rack. |
| Dried sweet potato | 1 ea | Wash a sweet potato and slice it in 1/8 - 1/2 inch thickness. Sprinkle sugar over sweet potato slices. Place the sweet potato slices on the low rack. |

Auto Cook

The oven offers 70 different auto cook options. You do not need to set either the cooking time or the power level. You can adjust the size of the serving.

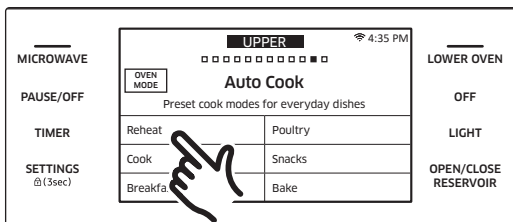

1. Put the food in the center of the optitray and close the door.
2. Tap **MICROWAVE** and swipe the screen to select **Auto Cook**. The display will show the Speed Cook and Soften/Melt menus. Choose the menu you want, and then view the auto cook programs in the menu by scrolling the list. The two menus together provide 70 auto cook options.

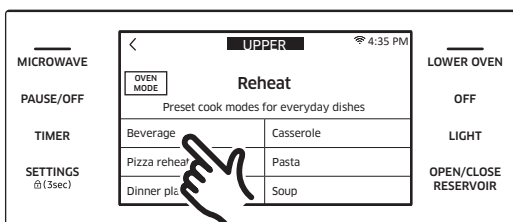

3. Tap the **Auto Cook** option you want.

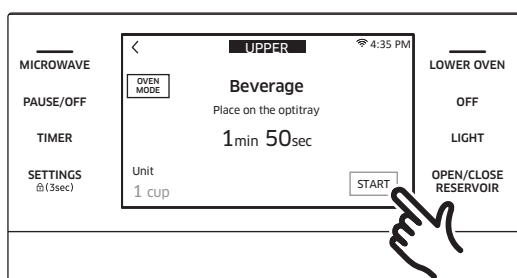
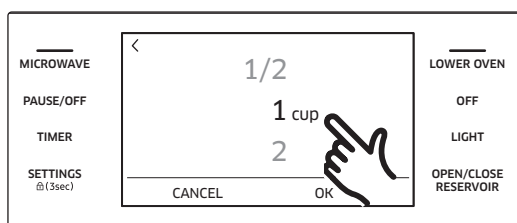
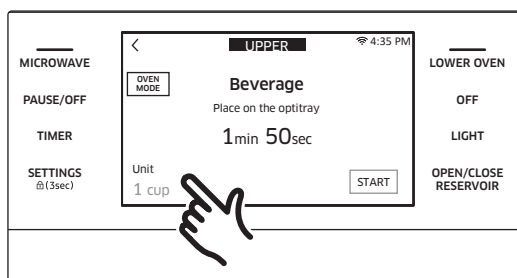

4. Tap the weight area to select the food weight screen.

5. Slide the screen to select the food weight.

6. Tap OK.

7. Tap **START** to start cooking.

8. If you want to pause cooking, tap **PAUSE**. In **PAUSE**, you can cancel or continue cooking by tapping **OFF** or **CONTINUE**.

⚠ CAUTION

- Use only microwave-safe cookware.
- Use oven gloves when taking out food.

| Food | Amount | Instructions |
|---------------------|----------|---|
| Reheat | | |
| Beverage | 1/2 cup | Use a measuring cup or mug and do not cover. Place the beverage in the oven. After heating, stir well. |
| | 1 cup | |
| | 2 cups | |
| Pizza reheat | 1 slice | Place 1-4 pizza slices on a microwave safe plate with the wide ends of the slices towards the outside edge of the plate. Do not let the slices overlap. Do not cover. |
| | 2 slices | |
| | 3 slices | |
| | 4 slices | |

Microwave oven (Upper Oven)

| Food | Amount | Instructions |
|--------------------------|---|---|
| Dinner plate | 1 serving | Use only precooked, refrigerated foods. Cover the plate with vented (1 inch vent) plastic wrap or waxed paper tucked under the plate. Contents: <ul style="list-style-type: none"> • 3-4 oz meat, poultry, or fish (up to 6 oz with bone) • 1/2 cup starch (potatoes, pasta, rice, etc.) • 1/2 cup vegetables (about 3-4 oz) |
| Casserole | 1 serving 2 servings 3 servings 4 servings | Pour into a deep ceramic plate or bowl. Cover the plate with vented (1 inch vent) plastic wrap. Stir well before serving. Contents: Casseroles: refrigerated |
| Pasta | 1 serving 2 servings 3 servings 4 servings | Pour into a deep ceramic plate or bowl. Cover the plate with vented (1 inch vent) plastic wrap. Stir well before serving. Contents: Pasta: canned spaghetti |
| Soup | 1 serving 2 servings 3 servings 4 servings | Pour into a deep ceramic plate or bowl. Cover the plate with vented (1 inch vent) plastic wrap. Stir well before serving. Contents: Soup: refrigerated |
| Cook | | |
| Frozen dinner | 8-10 oz 11-14 oz 15-18 oz | Remove package from wrapping and follow package instructions for covering and standing. After cooking, let stand 1-3 minutes. |
| Frozen breakfast | 4-6 oz 7-8 oz | Remove package from wrapping and follow package instructions for covering and standing. After cooking, let stand 1-3 minutes. |
| Mashed potatoes, Instant | 2 servings 4 servings (1 serving = 1/2 cup) | Follow package preparation directions. Stir well before serving. |

Microwave oven (Upper Oven)

| Food | Amount | Instructions |
|-------------------------|--------|---|
| Bacon, Uncooked | 2 ea | Layer 2 paper towels on a microwave-safe plate and arrange the bacon on the towels. Do not overlap bacon. Cover with an additional paper towel. Remove the paper towel immediately after cooking. |
| | 4 ea | |
| | 6 ea | |
| Bacon, Pre-cooked | 2 ea | Layer 2 paper towels on a microwave-safe plate and arrange the bacon on the towels. Do not overlap bacon. Cover with an additional paper towel. Remove the paper towel immediately after cooking. |
| | 4 ea | |
| | 6 ea | |
| Breakfast | | |
| Frozen french toast | 2 ea | Place the french toast on the high rack. |
| | 4 ea | |
| French toast sticks | 6 ea | Place the french toast sticks on the even plate. Place the plate on the low rack. |
| | 12 ea | |
| Sausage links, Frozen | 4 ea | Place the sausage links on the even plate. Place the plate on the low rack. |
| | 8 ea | |
| Sausage links, Fresh | 4 ea | Place the sausage links on the even plate. Place the plate on the low rack. |
| | 8 ea | |
| Sausage patties, Frozen | 2 ea | Place the sausage patties on the even plate. Place the plate on the high rack. |
| | 4 ea | |
| Sausage patties, Fresh | 2 ea | Place the sausage patties on the even plate. Place the plate on the high rack. |
| | 4 ea | |
| Frozen sandwich | 2 ea | Place the sandwich on the even plate, then place the plate on the low rack. |
| | 4 ea | |
| Frozen waffles | 2 ea | Place the waffles on the even plate, then place the plate on the low rack. |
| | 4 ea | |
| Frozen bagels | 2 ea | Place the bagels on the even plate, then place the plate on the low rack. |
| | 4 ea | |

Microwave oven (Upper Oven)

| Food | Amount | Instructions |
|---|-----------------------------------|--|
| Beef | | |
| Hamburger | 2 ea 4 ea (1 ea = 4 oz) | Place the hamburgers on the even plate. Place the plate on the high rack. When the microwave beeps, turn the hamburgers over, and then press START to continue. |
| Sirloin steak, Medium (1 inch) | 1.0 lb | Brush the Steaks with oil and seasonings. Place the steak on the high rack. When the microwave beeps, turn over the steak, and then press START to continue. Let the steak rest for 5 minutes before slicing. |
| Sirloin steak, Well done (1 inch) | 1.0 lb | Brush the Steaks with oil and seasonings. Place the steak on the high rack. When the microwave beeps, turn over the steak, and then press START to continue. Let the steak rest for 5 minutes before slicing. |
| Tenderloin steak, Medium (1 inch) | 1 inch 2 ea (1 ea = 1/2 lb) | Brush the Steaks with oil and seasonings. Place the steak on the high rack. When the microwave beeps, turn over the steak and then press START to continue. Let the steak rest for 5 minutes before slicing. |
| Tenderloin steak, Well done (1 inch) | 1 inch 2 ea (1 ea = 1/2 lb) | Brush the Steaks with oil and seasonings. Place the steak on the high rack. When the microwave beeps, turn over the steak and then press START to continue. Let the steak rest for 5 minutes before slicing. |
| T-Bone steak, Medium (1 inch) | 1 inch 1.5 lbs | Brush the Steaks with oil and seasonings. Place the steak on the high rack. When the microwave beeps, turn over the steak and then press START to continue. Let the steak rest for 5 minutes before slicing. |
| T-Bone steak, Well done (1 inch) | 1 inch 1.5 lbs | Brush the Steaks with oil and seasonings. Place the steak on the high rack. When the microwave beeps, turn over the steak and then press START to continue. Let the steak rest for 5 minutes before slicing. |

| Food | Amount | Instructions |
|------------------------|-------------------------------|---|
| Meat loaf | 2.5 lbs | <p>Ingredients: 1½ lbs ground beef, 1 egg, 1 onion (chopped), 1 cup milk, 1 cup dried bread crumbs, salt and pepper to taste</p> <p>Method: In a large bowl, combine the beef, egg, onion, milk, and bread crumbs. Season with salt and pepper to taste, and then place in a lightly greased 5 x 9 inch microwave-safe loaf pan. Place the pan on the low rack.</p> |
| Roast beef | 2.0 lbs 3.0 lbs | Brush the roast beef with oil and seasonings. Place the roast beef on the low rack. When the microwave beeps, turn over the roast beef, and then restart the microwave. |
| Pork | | |
| Barbecue pork ribs | 1.0 lb 2.0 lbs | Brush the pork ribs with barbecue sauce. Place the pork ribs on the low rack. |
| Boneless pork chops | 2ea 4ea (1 ea = 5-6 oz) | Brush the pork chops with oil and seasonings. Place the pork chops on the high rack. When the microwave beeps, turn over the pork chops, and then press START to continue. |
| Poultry | | |
| Bone-in chicken pieces | 1.0 lb 2.0 lbs | Brush the chicken pieces with oil and seasonings. Place the pieces skin-side down on the high rack. When the microwave beeps, turn over bone-in chicken pieces, and then press START to continue. |
| Whole chicken | 4.0 lbs 5.0 lbs | Brush the chicken oil and spices. Put breast side down in the middle of low rack. When the beep sounds, turn the chicken over using tongs, and then press START to continue. After cooking, let stand for 2-3 minutes. |
| Chicken breast | 0.75 lb 1.5 lbs | Put chicken breast on the high rack. Let stand for 1-2 minutes. |

Microwave oven (Upper Oven)

| Food | Amount | Instructions |
|---------------------|---|---|
| Turkey breast | 0.75 lb 1.5 lbs | Put turkey breast on the high rack. Let stand for 1-2 minutes. |
| Snacks | | |
| Popcorn | 1.5 oz 3.0 oz 3.5 oz (1 package) | Use only one microwave popcorn bag at a time. Be careful when removing the heated bag from the oven and when opening it. |
| Hot dog | 2 ea 4 ea | Pierce the hot dogs 3 times with a fork. Place the hot dogs on the even plate, then place the plate on the low rack. When the microwave beeps, add the buns, and then press START to continue. |
| Nachos | 1 serving | Arrange the tortilla chips uniformly on a microwave-safe plate, then place the plate on the high rack. Sprinkle evenly with cheese. Contents: <ul style="list-style-type: none"> • 4 to 5 oz tortilla chips • 1/2 cup grated cheese |
| Baked potato | 2 ea 4 ea | Pierce the potatoes 3 times with a fork. Place the potatoes on the low rack. After cooking, let the potatoes stand for 3-5 minutes. |
| Frozen garlic bread | 6 ea | Put frozen garlic bread on the even plate, then place the plate on the low rack. When the microwave beeps, turn the bread over, and then press START to continue. After cooking, let stand for 1-2 minutes. |

Microwave oven (Upper Oven)

| Food | Amount | Instructions |
|----------------------|----------------|---|
| Homemade gratin | 20 oz 40 oz | <p>Ingredients (40 oz): 25 oz potatoes, 4 oz milk, 4 oz cream, 1 oz beaten whole egg, 1 tsp each of salt, pepper, nutmeg, 5-6 oz grated mozzarella cheese, butter, thyme.</p> <ul style="list-style-type: none"> For a 20 oz recipe, use half the quantities above. <p>Method: Peel potatoes and slice them to 1/8-1/4 inch thickness. Spread the slices on a clean towel and keep them covered with the towel while you prepare the rest of the ingredients. Rub the surface of a gratin dish with the butter. Put the rest of the ingredients except grated cheese into a large bowl and stir well. Layer the potato slices in the dish slightly overlapping and pour the mixture over the potatoes. Spread the grated cheese over the top, and then put the gratin dish on the low rack. After cooking, let stand for 2-3 minutes. Serve sprinkled with a few fresh thyme leaves.</p> |
| Homemade lasagna | 40 oz | <p>Ingredients: 3/4 lb ground beef, 2 tbsp olive oil, 8 oz tomato sauce, 4 oz beef stock, 8 lasagna sheets, 1 onion (chopped), oregano, and basil to taste, 8 oz grated mozzarella cheese</p> <p>Method: Sauce: Heat the oil in a frying pan, then cook the ground beef and chopped onion for about 10 min until browned all over. Combine with the tomato sauce and beef stock, add the dried herbs. Bring to a boil, and then simmer for 30 minutes. Cook lasagna noodles according to the package directions. Layer noodle, meat sauce, and cheese then repeat. Sprinkle the remaining cheese evenly on the top layer. Place the oven dish on the low rack. After cooking, let stand for 2-3 minutes.</p> |
| Frozen soft pretzels | 2 ea 4 ea | Place the pretzels on the even plate, then place the plate on the low rack. |

Microwave oven (Upper Oven)

| Food | Amount | Instructions |
|-------------------------|-------------------------|--|
| Frozen churros | 2 ea 4 ea | Place the churros on the even plate, then place the plate on the high rack. |
| Homemade mac and cheese | 12 oz | Put oven dish on the low rack and cook. |
| Quesadilla | 1 ea 2 ea | Follow the package preparation instructions. Place the Quesadilla on the even plate, then place the plate on the low rack. |
| Toast Hawaii | 4 ea | Toast the bread slices first. Put the toast with topping on the high rack. Let stand for 2-3 minutes. |
| Frozen lasagna | 1 serving 2 servings | Place the frozen lasagna on the low rack. Let stand for 2-3 minutes. |
| Potato bites | 5 ea 10 ea | Place the potato bites on the even plate, then place the plate on the high rack. |
| Egg rolls | 10 ea 20 ea | Place the egg rolls on the even plate, then place the plate on the high rack. |
| Bake | | |
| Box cake mix | 1 pack | Pour the batter into 8 inch round cake pan. Place the pan on the low rack. |
| Brownie mix | 1 pack | Pour the batter into an 8 x 8 inch pan, then place the pan on the low rack. |
| Cookie dough, Frozen | 8 ea | Place 8 cookies on the even plate, then place the plate on the low rack. |
| Cookie dough, Chilled | 8 ea | Place 8 cookies on the even plate, then place the plate on the low rack. |

| Food | Amount | Instructions |
|----------------|--------|---|
| Biscuits | 8 ea | <p>Ingredients: 2 1/2 cups all-purpose flour, 1 tablespoon baking powder, 1 tablespoon sugar, 1 teaspoon salt, 5 tablespoons unsalted butter, cold, 1 cup buttermilk</p> <p>Method:</p> <ol style="list-style-type: none"> 1. Combine all ingredients except the buttermilk into a food processor and pulse the ingredients together. Pour the pulsed ingredients into a large bowl and mix in the buttermilk. 2. On a light floured surface hand press the dough until it is 1/2 inch thick then press and fold the dough 4 times into a rectangle. 3. Cut the dough into 8 round pieces and place on the even plate 1 inch apart. Place the plate on the low rack. |
| Cinnamon rolls | 1 ea | <p>Ingredients:</p> <p>Dough 1/4 ounce package yeast, 1/2 cup warm water, 1/2 cup milk, 1/4 cup white granulated sugar, 4 tablespoons butter, melted, 1 teaspoon salt, 2 eggs, 4 cups all-purpose flour</p> <p>Filling 4 tablespoons butter, softened, 1/2 cup brown sugar, 2 tablespoons ground cinnamon, 1/2 cup raisins, 3/4 cup chopped pecans</p> <p>Icing 8 ounce reduced-fat cream cheese, softened, 4 tablespoons butter, softened, 1 teaspoon vanilla extract, 3/4 cup powdered sugar</p> |

Microwave oven (Upper Oven)

| Food | Amount | Instructions |
|----------------|--------|--|
| Cinnamon rolls | 1 ea | <p>Method:</p> <p>Dough</p> <ol style="list-style-type: none"> 1. In a small bowl dissolve yeast with the warm water and set aside. In a large bowl mix the milk, melted butter, eggs, sugar and salt together then mix in the dissolved yeast mixture and the flour until the dough is formed. 2. Place the dough on lightly floured surface and knead for 5 minutes then placed in a greased bowl, cover and let rise for 1 hour. <p>Filling</p> <ol style="list-style-type: none"> 3. Place dough on a lightly floured surface and roll into a 13 by 9 inch rectangle. 4. In a small bowl mix the cinnamon and sugar together and set aside. Spread the softened butter over the dough and then evenly sprinkle with the cinnamon sugar mixture and then sprinkle with the raisins and pecans evenly. 5. Roll the dough into a log starting from the long side, pinch seal the dough and then cut into 1 inch slices. 6. Place the slices into a greased 9 x 13 inch baking pan closely together and then let rise for 1 hour before baking. 7. Place the pan on the low rack and press START. <p>Icing</p> <ol style="list-style-type: none"> 8. In a large bowl blend the cream cheese, butter, and vanilla until fluffy, then add the sugar and blend together until smooth. 9. Spread over semi-cooled cinnamon rolls. |

| Food | Amount | Instructions |
|------------------------|--------|---|
| Chocolate chip cookies | 8 ea | <p>Ingredients (16 ea):</p> <ul style="list-style-type: none"> 1 1/4 cups all-purpose flour, 1/2 teaspoon baking soda, 1/4 teaspoon salt, 1/2 cup butter, softened, 1 teaspoons vanilla extract, 1/4 cup white granulated sugar, 1/4 cup brown sugar, 1 eggs, 3/4 cups dark-chocolate morsels, 1/2 cup chopped walnuts <p>Method:</p> <ol style="list-style-type: none"> 1. In a large bowl combine the flour, baking soda and salt and set aside for later use. Using an electric mixer blend the butter, vanilla, white and brown sugar together, then mix in the eggs. Mix in the flour mixture until the dough forms then mix in the chocolate chips and walnuts. 2. Roll dough, about 2 tablespoons, into small balls and place on the even plate 2 inches apart. Place the plate on the low rack. |
| Oatmeal raisin cookies | 8 ea | <p>Ingredients:</p> <ul style="list-style-type: none"> 3/4 cups all-purpose flour, 1/2 teaspoon baking soda, 1/2 teaspoon baking powder, 1/2 teaspoon ground cinnamon, 1/4 teaspoon salt, 1/2 cup butter, softened, 1 teaspoon vanilla extract, 1/4 cup white granulated sugar, 1/4 cup brown sugar, 1 eggs, 1 1/2 cups oats, 1/2 cup raisins <p>Method:</p> <ol style="list-style-type: none"> 1. In a large bowl mix together the flour, baking soda, baking powder, cinnamon and salt and set aside for later use. In a large bowl using an electric mixer blend the butter, vanilla, white and brown sugar, and then mix in the eggs. Mix in the flour mixture until the dough forms then mix in the oats and raisins. 2. Roll dough, about 2 tablespoons, into small balls and place on the even plate 2 inch apart. Place the plate on the low rack. |

Microwave oven (Upper Oven)

| Food | Amount | Instructions |
|-------------|--------|--|
| Cupcakes | 6 ea | Place 6 cupcakes on the 6 cup muffin mold, then place the mold on the low rack. |
| Marble cake | 1 ea | Put the fresh dough into round cake pan. Put the dish on the low rack. After baking, let stand for 5-10 minutes. |
| Cheese cake | 1 ea | <p>Ingredients: 15 graham crackers, crushed, 1/2 cup butter, 14 oz cream cheese, softened, 2 eggs, 1 cup granulated sugar, 1 teaspoon vanilla extract</p> <p>Method:</p> <ol style="list-style-type: none"> 1. Melt the butter in a pan and add the crushed biscuits and stir until coated in all the butter. Spread over the bottom of the 8 inch tin and press down to be firm. 2. Mix the cream cheese, eggs, sugar and vanilla extract until smooth. Pour it over the biscuit base and spread out with a spatula. 3. Place the tin on the low rack. After baking, let cool and then refrigerate for 5 hours before serving. |
| Pound cake | 1 ea | <p>Ingredients: 1 1/3 sticks butter, softened, 2/3 cups sugar, 3 eggs, 2 cups all-purpose flour, 3/4 teaspoon baking powder, 2/3 cup milk, 1 1/3 teaspoon vanilla extract</p> <p>Method:</p> <ol style="list-style-type: none"> 1. In a large bowl mix together the butter and sugar then add the eggs and mix until smooth. Mix in the remaining ingredients. 2. Pour batter into a greased tube pan. Put the pan on the low rack. |

| Food | Amount | Instructions |
|---------------------------|---------|---|
| Pizza | | |
| Frozen pizza (6 inch) | 6 inch | Place the pizza on the high rack. |
| Frozen pizza (12 inch) | 12 inch | Place the pizza on the low rack. |
| Frozen rising crust pizza | 12 inch | Place the pizza on the low rack. |
| Homemade pizza | 12 inch | <p>Ingredients:</p> <p>Pizza dough (10 oz) 10 oz strong white bread flour, 1/4 oz dried yeast, 1 tbsp olive oil, 1 tbsp sugar, 1 tbsp salt, 7 oz warm water</p> <p>Topping 4 tbsp tomato sauce, 2 oz bacon, 1 oz pepper, 1 oz mushroom, 5 oz mozzarella cheese</p> <p>Method:</p> <ol style="list-style-type: none"> 1. Put the flour, yeast, oil, salt and warm water in a bowl and mix to a moist dough. Knead in a mixer or by hand about 5-10 mins. Cover with lid and proof with 'Pizza dough' auto cook menu. 2. Roll out into Crusty plate. Spread the tomato sauce on the dough and add vegetables. Sprinkle cheese evenly on top. Put pizza on the low rack. After cooking, stand for 2-3 minutes. |

Microwave oven (Upper Oven)

| Food | Amount | Instructions |
|---------------------|--------|--|
| Dough Proof/Yogurt | | |
| Pizza dough | 1 ea | Put dough in suitable bowl and cover with plastic wrap. |
| Bread dough | 1 ea | Put dough in suitable bowl and cover with plastic wrap. |
| Yogurt - Small cups | 5 ea | Distribute 5 oz natural yogurt into 5 ceramic cups or small glass jars evenly (1 oz each). Add 1/2 cup milk into each cup. Use long-life milk (room-temperature; 3.5 % fat). Cover each with plastic wrap and set in a circle on optitray. When finished, keep 6 hours in a refrigerator. For the first time we recommend using dried yogurt bacteria ferment. |
| Yogurt - Large bowl | 16 oz | Mix 5 oz natural yogurt with 2-3 cups long-life milk (room-temperature; 3.5 % fat). Pour evenly into large glass bowl. Cover with plastic wrap and set on optitray. When finished, keep 6 hours in a refrigerator. For the first time we recommend using dried yogurt bacteria ferment. |

Microwave oven (Upper Oven)

Soften / Melt

The oven offers 8 different Soften/Melt options. You do not need to set either the cooking time or the power level. You can adjust the size of serving.

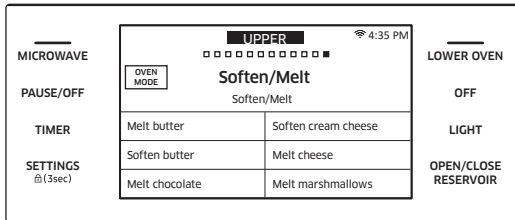

1. Put the food in the center of the optitray and close the door.
2. Touch **MICROWAVE** and swipe the screen to select Sense Cook. The display will show 8 **Soften/Melt** options. (You can scroll down through the list.)

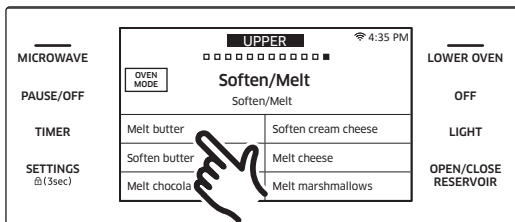

3. Tap the **Soften/Melt** option you want.

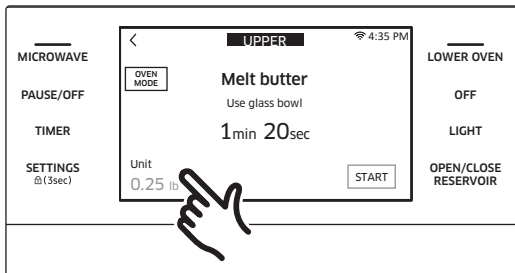

4. Tap the weight area to select the food weight screen.

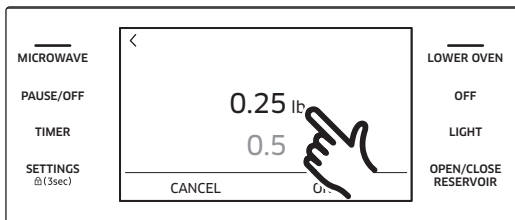

5. Slide the screen to select the food weight.
6. Tap **OK**.

Microwave oven (Upper Oven)

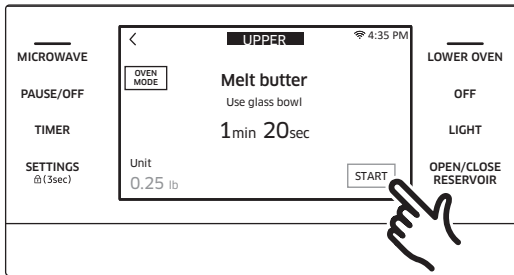

7. Tap **START** to start cooking.
8. If you want to pause cooking, tap **PAUSE**. In **PAUSE**, you can cancel or continue cooking by tapping **OFF** or **CONTINUE**.

| Food | Amount | Instructions |
|---------------------|---|---|
| Soften/Melt | | |
| Melt butter | 0.25 lb (1 stick) 0.5 lb (2 sticks) | Unwrap the butter and cut the butter into several pieces. Place the butter on a microwave-safe dish and cover with wax paper. Stir well afterwards. |
| Soften butter | 0.25 lb (1 stick) 0.5 lb (2 sticks) | Remove the butter from the packaging and place on a microwave-safe dish. |
| Melt chocolate | 1 cup chips | Place the chocolate chips in a microwave-safe dish. When the microwave beeps, stir well, and then press START to continue. Unless stirred, the chocolate chips will keep their shape even when the heating time is over. |
| Soften ice cream | 1 serving: 1 pint 2 servings: 1.5 quarts | Remove the lid of the carton. Place the carton in the center of the microwave. |
| Soften cream cheese | 4 oz 8 oz | Unwrap the cream cheese and place on a microwave safe dish. |
| Melt cheese | 4 oz 8 oz | Place the cheese in a microwave-safe bowl and cover with wax paper. Stir well afterwards. |
| Melt marshmallows | 5 oz 10 oz | Place the marshmallows in a large microwave-safe dish. Stir well afterwards. |
| Melt caramel | 4 oz 8 oz | Place the caramel in a large microwave-safe dish. Stir well afterwards. |

Oven (Lower Oven)

Timed cooking

In timed cooking mode, the oven turns on immediately and cooks for the length of time you select.

At the end of the cooking time, the oven turns off automatically.

- You can use the timed cooking feature only with another cooking operation. (Bake, Convection Bake, Convection Roast, Broil, Pure Convection Sear, Convection Broil, Steam Bake, Steam Roast, Dual Four Part Pure Convection, Proof, Stone Bake Mode, Dehydrate).

How to set the oven for timed cooking

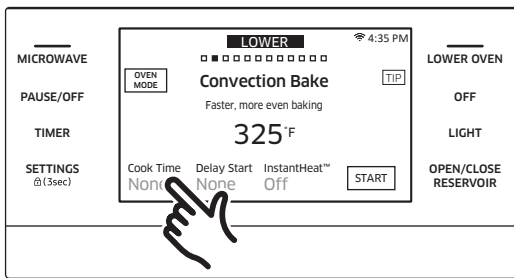

1. Tap **LOWER OVEN** and swipe the screen to select the cooking operation you want.
2. Tap **Cook Time**. The display will change to the cooking time screen.

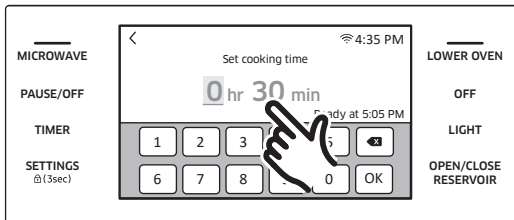

3. Tap numbers in the numeric pad to set the cooking time. (You can set the cooking time for any amount of time from 1 minute to 9 hours, 59 minutes).

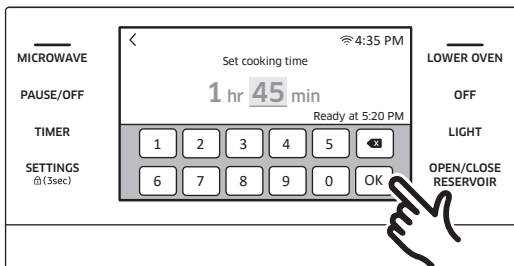

Oven (Lower Oven)

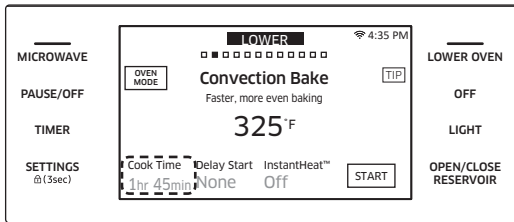

4. Tap **OK**. The cooking time screen closes. The cooking time is displayed in the **Cook Time** area on the screen.
5. Tap **START** to start cooking.
6. You can cancel a cook time at any time by setting the **Cook Time** to 0 minutes.

NOTE

See pages **93** through **95** for basic baking and broiling instructions.

CAUTION

Use caution with the timed cooking or delay start features. You can use these features to cook cured or frozen meats and most fruits and vegetables.

For food that can easily spoil, such as milk, eggs, and unfrozen or fresh fish, meat, or poultry, chill them in the refrigerator first.

Even when chilled, they should not stand in the oven for more than 1 hour before cooking begins, and should be removed promptly when cooking is completed.

Eating spoiled food can result in sickness from food poisoning.

Delay start

In the delay timed cooking mode, the oven's timer turns the oven on at a time you select in advance. You can have the oven turn off automatically after a set time has elapsed by setting the Timed Cooking function as well.

- You can use the delay start feature only with another cooking operation (Bake, Convection Bake, Convection Roast, Pure Convection Sear, Steam Bake, Steam Roast, Dual Four Part Pure Convection, Proof, Stone Bake Mode, Dehydrate, Self clean, GreenClean™).
- You can set the oven for a delayed start before setting other cooking operations.
- The clock must be set to the current time.

How to set the oven for delay timed cooking



1. Position the oven rack(s) and place the food in the oven.
2. Tap **LOWER OVEN** and swipe the screen to select the cooking operation you want.
3. Set the cooking time if you want the oven to turn off automatically after a set time.
(See the **Timed cooking** section on page 83).
4. Tap **Delay start**. The current time is displayed as the first entry.
5. Tap numbers in the numeric pad to set the time you want the oven to start.

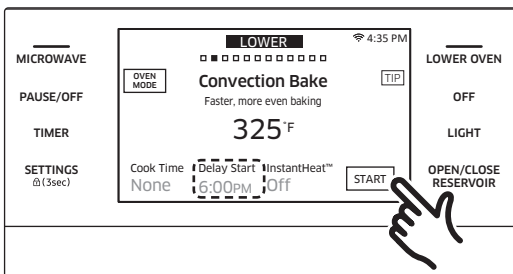
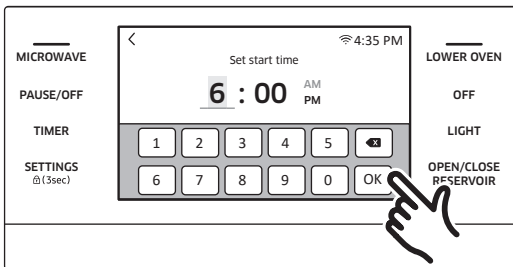

6. Tap **OK**. The Delay Start screen closes. The start time, and, if you set it, the cooking time, is displayed on the screen.
7. Tap **START** to start cooking.

NOTE

See pages 93 through 95 for basic baking and broiling instructions.

Oven (Lower Oven)

Using the temp probe

For many foods, especially roasts (beef, pork, lamb, etc) and poultry (chicken, turkey, etc), measuring the internal temperature is the best way to determine that the food is properly cooked. The Temp probe lets you cook meat to the exact internal temperature you want. This function can be used with Bake, Convection Bake, or Convection Roast.

After the internal temperature of the food reaches 100 °F, the increasing internal temperature will be shown in the display.

How to use the temp probe

1. Push the tip of the Temp probe into the meat as fully as possible, so that the tip is in the center of the meat.

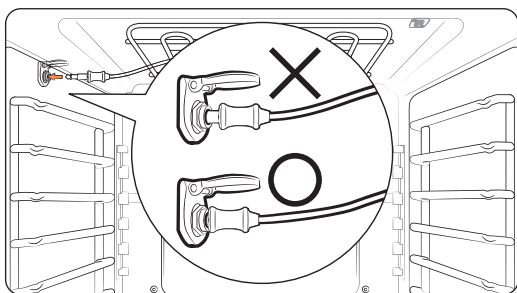
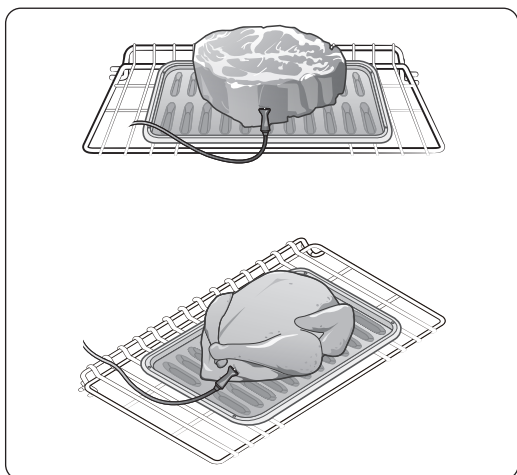

- Insert the probe completely into the meat as shown in the illustrations. It should not touch bone, fat, or gristle.
- If you do not fully insert the probe into the meat, the Temp Probe function will not work correctly because the probe will sense the oven temperature, not the temperature of the meat.
- For bone-in meats, insert the probe into the center of the lowest and thickest portion of the piece.
- For whole poultry (turkey, large chickens, etc.), insert the probe into the thickest part of the inner thigh, parallel to the leg.
- If you activate the Keep Warm function to keep the meat warm after you have cooked it using the Temp Probe function, the meat's internal temperature will exceed the temperature you want.

-
2. Insert the temp probe plug into the socket on the top side wall of the oven as far as it will go.
 3. Tap **LOWER OVEN** and swipe the screen to select the desired cooking mode (Bake, Convection Bake, Convection Roast, Pure Conv.Sear, or 4 Part Pure Convection).
 4. Tap **Temp Probe** to set the desired internal temperature.
 5. Set the desired internal temperature using the numeric pad.

| | |
|------------------------|------------------|
| Available temperatures | 100 °F to 200 °F |
|------------------------|------------------|

6. If you want to use the Cook time or Delay start, set each function.
7. Tap **START**.
8. When the desired internal temperature is reached, the function automatically stops and an alarm sounds.

 **CAUTION**

To protect the Temp probe's tip, be careful not to insert the probe so that the tip protrudes through the surface of the meat. Make sure that the tip is in or near the center of the meat.

- Do not store the probe in the oven.
- Do not leave the probe inside the oven during a self-cleaning or broiling cycle. You can permanently damage the probe and it will no longer work.
- To avoid breaking the probe's tip, defrost your food completely.
- Do not use tongs when inserting or removing the probe. Tongs can damage the probe.
- Use the Temp probe for Temp Probe function cooking only. Do not use the Temp probe for any other purpose.

 **NOTE**

- If you remove the Temp probe while the Temp Probe function is operating or insert the Temp probe while baking or cooking normally, cooking will stop after 1 minute.
- If you use the probe to cook frozen food, there are times when probe cannot be detected by the oven. (The probe icon will not appear in the display.)

Oven (Lower Oven)

Temp probe table

| Type of Food | | Internal temperature |
|--------------|-----------|----------------------|
| Beef / Lamb | Rare | 140 °F |
| | Medium | 160 °F |
| | Well done | 170 °F |
| Pork | | 170 °F |
| Poultry | | 180-185 °F |

NOTE

If you cover the meat with aluminum foil and allow it to stand for 10 minutes after cooking, the Internal temperature will rise 5-10 degrees.

Removing the temp probe

Remove the temp probe plug from the socket.

CAUTION

After cooking, the Temp probe is hot enough to cause burns. Let it cool sufficiently before attempting to remove it.

Oven functions

Cooking mode

Tap **LOWER OVEN** and swipe to select the cooking mode. See Basic baking and broiling instructions starting on page 93.

| Mode | Temperature range | Lower | Temp probe | InstantHeat™ |
|--------------------------------|-----------------------------------|-------|------------|--------------|
| Bake | 175 °F (80 °C) - 550 °F (285 °C) | ✓ | ✓ | - |
| Convection Bake | 175 °F (80 °C) - 550 °F (285 °C) | ✓ | ✓ | ✓ |
| Convection Roast | 175 °F (80 °C) - 550 °F (285 °C) | ✓ | ✓ | ✓ |
| Broil | LO / HI | ✓ | - | - |
| Pure Conv. Sear | 175 °F (80 °C) - 475 °F (245 °C) | ✓ | ✓ | - |
| Convection Broil | 175 °F (80 °C) - 550 °F (285 °C) | ✓ | - | - |
| Steam Bake | 230 °F (110 °C) - 550 °F (285 °C) | ✓ | ✓ | - |
| Steam Roast | 230 °F (110 °C) - 550 °F (285 °C) | ✓ | ✓ | - |
| Dual Four Part Pure Convection | 175 °F (80 °C) - 550 °F (285 °C) | ✓ | ✓ | - |

✓ = Available

- = Not Available

| Mode | Description |
|-----------------|--|
| Bake | <ul style="list-style-type: none"> Bake is used to cook cakes, cookies, and casseroles. Always preheat the oven first. Baking temperatures and times will vary depending on the ingredients and the size and shape of the baking pan used. Dark or nonstick coatings may cook faster with more browning. <p> NOTE For performance reasons, the convection fan may turn on or off during baking.</p> |
| Convection Bake | <ul style="list-style-type: none"> Convection Bake uses a fan to circulate the oven's heat evenly and continuously within the oven. This improved heat distribution allows for even cooking and excellent results while using multiple racks at the same time. Breads and pastries brown more evenly. |

Oven (Lower Oven)

| Mode | Description |
|------------------|---|
| Convection Roast | <ul style="list-style-type: none"> • Convection Roast is good for cooking large tender cuts of meat, uncovered. The convection fan circulates the heated air evenly over and around the food. • Meat and poultry are browned on all sides as if they were cooked on a rotisserie. • The heated air seals in juices quickly for moist and tender results while, at the same time, creating a rich golden brown exterior. |
| Broil | <ul style="list-style-type: none"> • Broiling is a method of cooking tender cuts of meat by direct heat under the broil element of the oven. • The high heat cooks quickly and gives a rich, brown outer appearance. Broil mode is best for meats, fish, and poultry up to 1 inch thick. • Always preheat the oven for 5 minutes before broiling. • See the Broiling recommendation guide section starting on page 92. |
| Pure Conv. Sear | <p>Pure Convection sear uses the convection element and fan. In Pure Convection Sear mode, the oven cooks the meat 75 °F (42 °C) higher than the set temperature for the first 15 minutes. The resulting browning process sears the surface of the meat to keep the natural juices from escaping. This mode is best for game hens, chickens, stuffed and un-stuffed turkeys, turkey breasts, pork tenderloin and pork loins.</p> |
| Convection Broil | <ul style="list-style-type: none"> • Convection Broil is similar to Broil, but with the additional benefit of air circulation by the motorized fan in the rear of the oven. • During Convection Broil mode, the broil element will cycle on and off in intervals to maintain oven temperature, while the fan circulates the hot air. • Use this mode for thicker cuts of meat, fish, and poultry. Convection Broil gently browns the exterior and seals in the juices. • For optimum browning, preheat the broil element for 5 minutes. |
| Steam Bake | <ul style="list-style-type: none"> • Steam Bake provides excellent baking conditions for breads, pastries, and desserts by increasing moisture content and improving texture and flavor. • See the Steam cook recommendation guide section starting on page 93. |

| Mode | Description |
|--------------------------------|---|
| Steam Roast | <ul style="list-style-type: none"> • Steam Roast provides excellent cooking conditions for roasted meats or poultry by maintaining a crispy surface while sealing in the juices for a moist and tender result. • See the Steam cook recommendation guide section starting on page 93. |
| Dual Four Part Pure Convection | <p>Dual Four Part Pure Convection uses the convection element and fan. The uniform air circulation provided by Dual Four Part Pure Convection allows you to use more oven capacity at once. Use this mode for single rack baking, multiple rack baking, roasting, and preparation of complete meals. Many foods, such as pizzas, cakes, cookies, biscuits, muffins, rolls and frozen convenience foods can be successfully prepared on two or three racks at a time. Dual Four Part Pure Convection is also good for whole roasted duck, lamb shoulder and short leg of lamb.</p> |

Oven (Lower Oven)

Broiling recommendation guide

The size, weight, thickness, starting temperature, and your doneness preference will affect broiling times. This guide is based on meats at refrigerator temperature. Always use a broiler pan and its grid when broiling. Always preheat the oven for 5 minutes before broiling.

| Food | Doneness | Size | Thickness | Level | Rack position | Cooking time (min.) | |
|----------------|-----------|-----------|-----------|-------|---------------|---------------------|-------------|
| | | | | | | 1st side | 2nd side |
| Hamburgers | Medium | 9 patties | 3/4" | Hi | 6 | 3:00 | 2:00 |
| | Medium | 9 patties | 1" | Hi | 6 | 3:20 | 2:20 |
| Beef steaks | Rare | - | 1" | Hi | 5 | 5:00 | 4:00 |
| | Medium | - | 1-1 1/2" | Hi | 5 | 6:00-6:30 | 4:30-4:00 |
| | Well done | - | 1-1 1/2" | Lo | 4 | 7:00-8:00 | 4:00-5:00 |
| Chicken pieces | Well done | 4.5 lbs | 1/2-3/4" | Lo | 3 | 16:00-18:00 | 13:00-15:00 |
| | Well done | 2 lbs | 1/2-3/4" | Lo | 3 or 4 | 15:00-16:00 | 10:00-12:00 |
| Pork chops | Well done | 1 lbs | 1" | Lo | 3 | 8:00-10:00 | 6:00-8:00 |
| Fish fillets | Well done | - | 1/4-1/2" | Lo | 3 or 4 | 7:00-8:00 | 4:00-5:00 |

Steam cook recommendation guide

| Steam mode | Level | Foods |
|-------------|-------|---|
| Steam bake | High | Rye breads, Desserts (Flan caramel) |
| | Med | Croissants, Pies, Reheats (Pizza, Casseroles) |
| | Low | Pastries |
| Steam Roast | High | - |
| | Med | Meats, Poultry |
| | Low | Turkey, Large meats |

Basic baking and broiling instructions

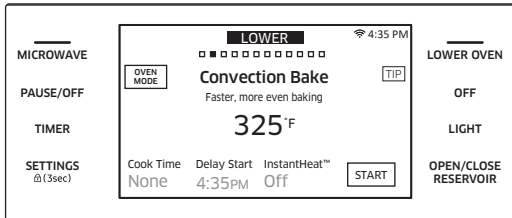

1. Tap **LOWER OVEN** and swipe the screen to select the desired cooking mode.

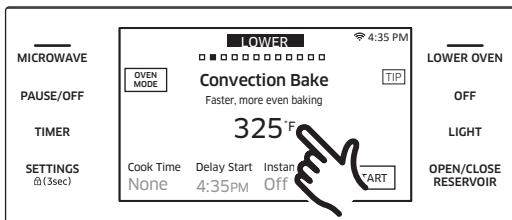

2. Set the temperature you want. (See the **Cooking mode** on page 89.)
 - Broil mode can be set only Hi or Low.
 - Keep Warm and Bread Proof temperatures are fixed and cannot be changed.

Oven (Lower Oven)

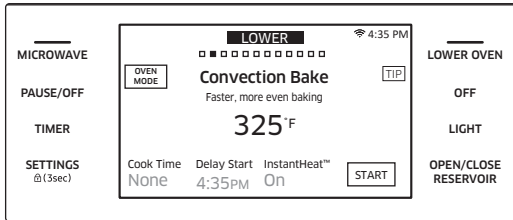
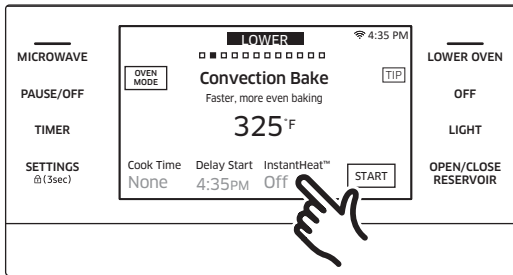

3. Follow the steps below to use the Instant Heat™ feature, Steam Bake, or Steam Roast. If you are not using these features, skip these steps and go to Step 5 on the next page.

- Instant Heat™
 - a. If you select Convection Bake or Convection Roast, the display will show the **Instant Heat™** information. (The default is OFF).
 - b. Tap the Instant Heat™ area. The Instant Heat™ feature is activated and the display will show ON.

NOTE

- For best performance, we recommend cooking on a single rack.

| Type | Rack Positions |
|----------|----------------|
| Baking | 3 or 4 |
| Roasting | 1 or 2 |

- Place food in the oven before you start cooking when using the InstantHeat™ feature.
- For best performance, preheat the oven when baking rising bakery products such as angel food cakes, bundt cakes, or puff pastries.

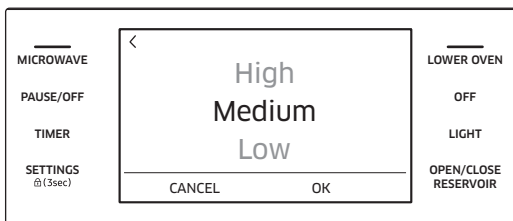

- **Steam Bake, Steam Roast**
Important: You must fill the water reservoir before you start steam cooking. See the **Water reservoir** section on page 28.
 - a. If you selected Steam Bake or Steam Roast, the display will show the steam level information. (The default is Medium).
 - b. Tap the Steam area to adjust the steam level. The steam level adjustment screen appears. You can set the steam level to Low, Medium, or High.

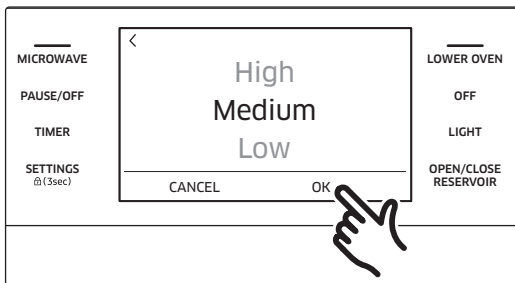

c. Tap **OK**. The steam level adjustment screen closes and the steam level information is displayed.

4. If you want to use the **Cook Time**, or **Delay Start** function, set each function now. See pages 83 and 85 for instructions.

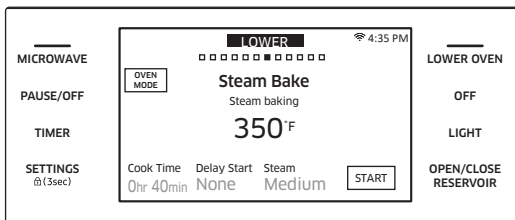

5. Tap **START** to begin cooking.

6. Tap **OFF** when cooking is done or if you want to cancel cooking.

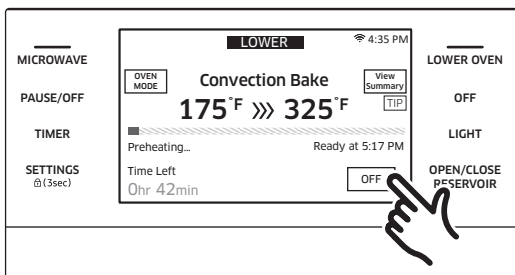
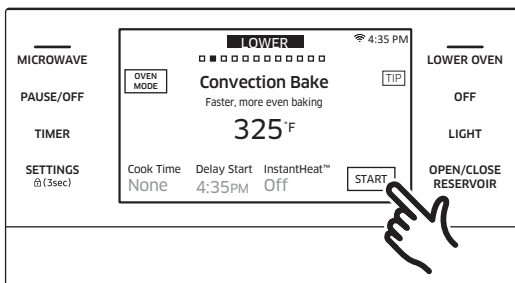

Oven (Lower Oven)

How to adjust the temperature while cooking

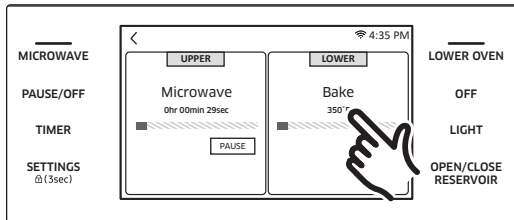

To adjust the temperature in the lower oven

- Tap **LOWER** area on the screen, tap the temperature area, enter the new temperature using the numeric keypad, and then tap **OK**.

To adjust the temperature in the upper microwave oven

- Tap **MICROWAVE** on the screen, tap the temperature area, enter the new temperature using the numeric keypad, and then tap **OK**.

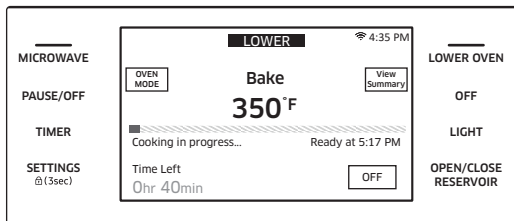

- Place food in the oven after preheating if the recipe calls for it. Preheating is very important for good results when baking cakes, cookies, pastry, and breads. After the oven has reached the desired temperature, the oven will beep 6 times.
- The convection oven fan shuts off when the oven door is opened.
- DO NOT leave the door open for long periods of time while using convection cooking or you may shorten the life of the convection heating element.

NOTE

- If you leave the oven door open for more than 2 minutes when the oven is on, all heating elements will shut off automatically.
- When you have finished cooking, the cooling fan will continue to run until the oven has cooled down.
- Make sure to drain the remaining water after using steam cooking. Once the oven starts draining, wait until the draining cycle is complete.
- When a steam function is complete, you must empty the water reservoir because the remaining water can affect other cooking modes.
- If you are using an oven thermometer in the oven cavity, the temperature registered by the thermometer may differ from the actual set oven temperature.
- For performance reasons, the convection fan may turn on or off while the oven is cooking.
- This oven is designed for CLOSED DOOR broiling. The oven door must be closed during broiling.

CAUTION

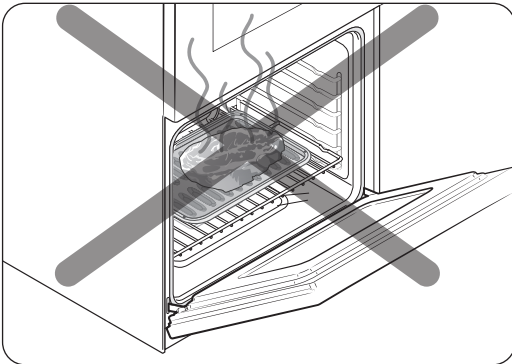

Always broil with the oven door closed. Use care when opening the door. Let hot air or steam escape before you remove food from or put food into the oven.

Oven (Lower Oven)

Using the special function feature

Special function provides 4 different specialized cooking options.

| Mode | Temperature range | Lower |
|-----------------|----------------------------------|-------|
| Keep Warm | **None | |
| Proof | 95 °F (35 °C) / 105 °F (40 °C) | |
| Stone Bake Mode | 175 °F (80 °C) - 550 °F (285 °C) | |
| Dehydrate | 105 °F (40 °C) - 225 °F (105 °C) | |

** None means that a factory set temperature is applied for the best performance. You cannot adjust this temperature.

| Mode | Description | | | | | | | | | |
|---------------------|---|------------------|---------------|------------------|---------------------|--------|---------|------|--------|---------|
| Keep Warm | <ul style="list-style-type: none"> The keep warm mode will keep cooked food warm for serving up to 3 hours after cooking has finished. You can use the keep warm mode without any other cooking operations or you can set it to activate after a timed or delay timed cooking operation. You should not use this mode to reheat cold food. | | | | | | | | | |
| Proof | <ul style="list-style-type: none"> Proof provides an optimal temperature (100 °F / 110 °F) for the bread proofing process. For the best results, always start the Proof option with a cool oven. | | | | | | | | | |
| Stone Bake Mode | <ul style="list-style-type: none"> Stone accessory not included. Bake on a baking or pizza stone for pizza and bread. Always do preheat with a stone for the best results. | | | | | | | | | |
| Dehydrate | <ul style="list-style-type: none"> Dehydrate removes moisture from food via heat circulation. After drying the food, keep it in a cool and dry place. For fruit, adding lemon or pineapple juice or sprinkling sugar on the fruit helps the fruit retain sweetness. See the table below for Dehydrate settings. <table border="1" data-bbox="353 1437 1240 1566"> <thead> <tr> <th>Category</th> <th>Rack position</th> <th>Temperature (°F)</th> </tr> </thead> <tbody> <tr> <td>Vegetables or Fruit</td> <td>3 or 4</td> <td>105-150</td> </tr> <tr> <td>Meat</td> <td>3 or 4</td> <td>145-225</td> </tr> </tbody> </table> | Category | Rack position | Temperature (°F) | Vegetables or Fruit | 3 or 4 | 105-150 | Meat | 3 or 4 | 145-225 |
| Category | Rack position | Temperature (°F) | | | | | | | | |
| Vegetables or Fruit | 3 or 4 | 105-150 | | | | | | | | |
| Meat | 3 or 4 | 145-225 | | | | | | | | |

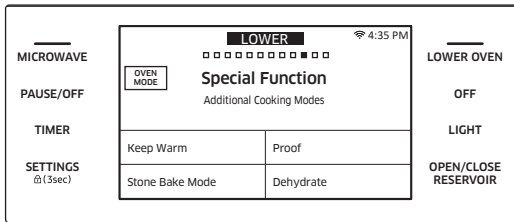

1. Tap **LOWER OVEN** and swipe the screen to the **Special** function. The display will show the specialized cooking options.

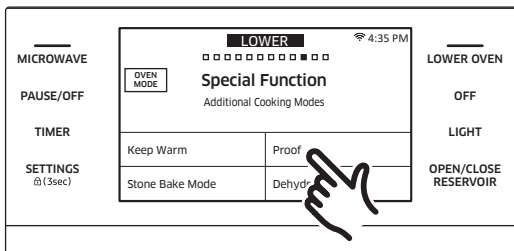

2. Tap the cooking option you want.

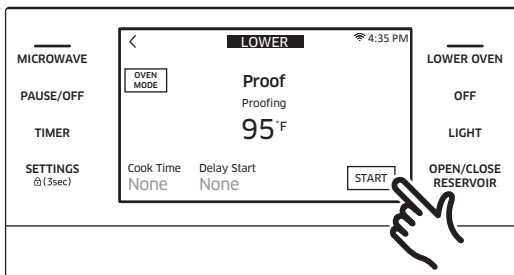

3. Set the temperature you want.
4. Tap **START**.

NOTE

You cannot adjust the temperature of the Keep Warm mode.

CAUTION

- Do not use Proof when the oven temperature is above 125 °F. If temperature is above 125 °F, this mode will not function properly. Wait until the oven cools down.
- Do not use Proof for warming food. The proofing temperature is not hot enough to keep food warm.
- Place the dough in a heat-safe container on rack position 3 or 4 and cover it with a cloth or with plastic wrap. You may need to anchor the plastic wrap underneath the container so that the oven does not blow the plastic wrap off the dough.
- To avoid lowering the temperature and extending proofing time, do not open the oven door.

NOTE

- Preheating is not necessary on special function feature except Stone Bake Mode.
- An error beep sounds if the temperature setting is out of the set range.

Oven (Lower Oven)

Rack position chart for special cooking options

| Mode | Rack position |
|-----------------|---------------|
| Keep Warm | 5 |
| Proof | 3 |
| Stone Bake Mode | 1 or 2 |
| Dehydrate | 3 or 4 |

Using the chef mode feature

For inexperienced cooks, the oven offers 15 gourmet auto-cook options.

Take advantage of this feature to save time or shorten your learning curve.

The cooking time and temperature will be adjusted according to the selected recipe. You can download detailed recipes for each option from the Dacor website.

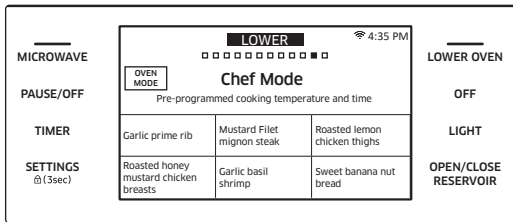

1. Tap **LOWER OVEN** and swipe the screen to the **Chef Mode** mode. The display will show 15 auto-cook options. (You can scroll down through the list.)

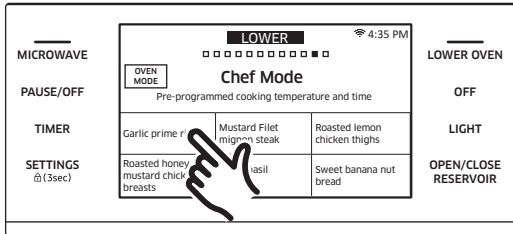

2. Tap the Chef Mode option you want.

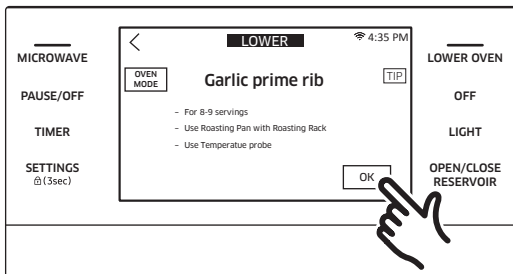

3. Follow the on-screen instructions.

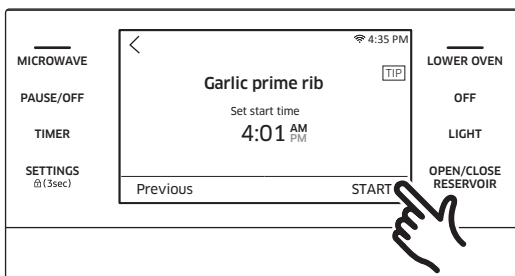

4. Tap **START** to start cooking.

Cooking tips in the chef mode mode

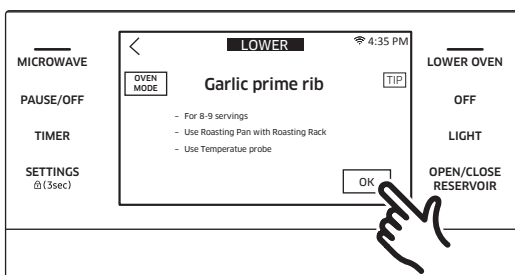

1. Tap **OK**.

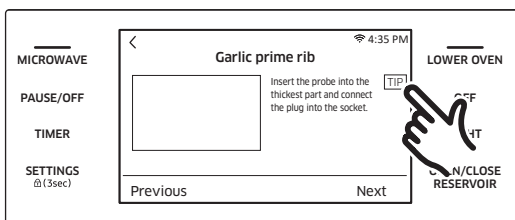

2. Tap **TIP** on the screen to see a cooking tip.

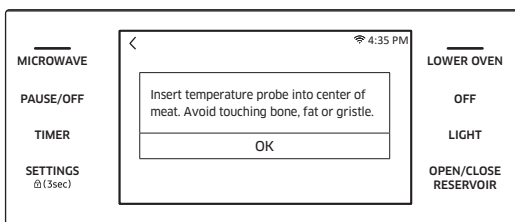

3. The display will show the cooking tip. You can see the cooking tip before you start cooking or while you are cooking.

Oven (Lower Oven)

Using the iQ control feature (Lower oven only)

To use the oven's iQ Control feature, you must download The SmartThings app to a mobile device. Functions that can be operated using The SmartThings app may not work smoothly if communication conditions are poor or the oven is installed in a place with a weak Wi-Fi signal.

Refer to the following table for the main functions that can be operated from the app.

| | |
|-------------------------------------|--|
| When iQ Control on the oven is off. | Monitoring (Microwave, Lower Oven, Probe), Lower Oven off |
| When iQ Control on the oven is on. | Monitoring (Microwave, Lower Oven, Probe), Lower Oven start, Lower Oven off, Error check |

How to connect the oven

1. Download and open the SmartThings app on your smart device.
2. Follow the app's on-screen instructions to connect your oven.
3. Once the process is complete, the connected  icon located on your oven displays and the app will confirm you are connected.
4. If the connection icon does not turn on, follow the instruction in the app to reconnect.

To start the oven remotely

Tap **SETTINGS** > **iQ Control**, and then tap **ON** or **LOWER OVEN**. The oven can now be started and controlled remotely by a connected mobile device.

When iQ Control is on you can:

- Remotely change oven settings (mode, time, temperature) using your mobile device.
- Remotely start the oven.
- Remotely turn off the oven.
- Once cooking starts, you can change the cooking time and temperature remotely.

NOTE

Important: **Self Clean** mode cannot be started remotely.

- Opening the oven door will deactivate iQ Control and prevent you from turning the oven on or controlling the oven remotely.
- If iQ Control is deactivated, you can still monitor the oven's status and turn the oven off.
- When oven cooking is finished or cancelled, iQ Control will be deactivated.

Oven (Lower Oven)

Using the oven racks

Lower oven rack positions

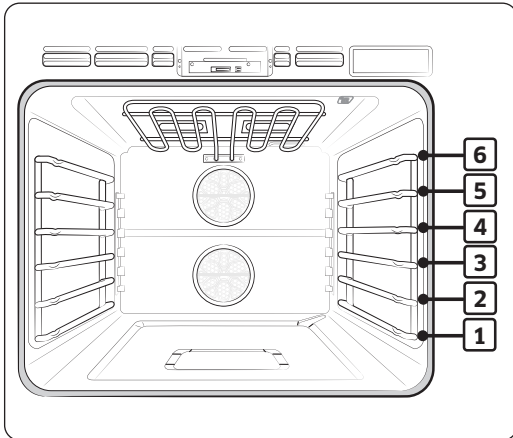

Recommended rack positions for cooking

| Type of Food | Rack Positions |
|---|----------------|
| Broiling hamburgers | 6 |
| Broiling meats or small cuts of poultry, fish | 3-5 |
| Bundt cakes, pound cakes, frozen pies, casseroles | 4 or 3 |
| Angel food cakes, small roasts | 2 |
| Turkeys, large roasts, hams, fresh pizza | 1 |

- This table is for reference only.

Rack and pan placement

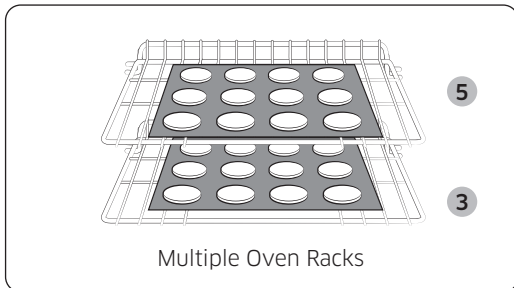
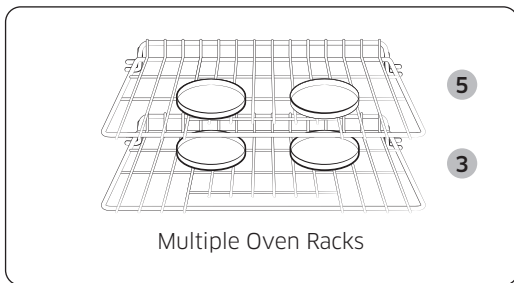
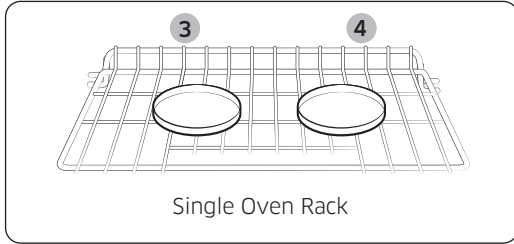

Centering baking pans in the oven as much as possible will produce better results. If baking with more than one pan, place the pans so each has at least 1" to 1 1/2" of air space around it.

When baking on a single oven rack, place the oven rack in **position 3** or **4**. See the figure on the left.

When baking cakes and cookies on multiple racks, place the oven racks in **positions 3 and 5**.

Using multiple oven racks

| Type of Baking | Rack Positions |
|-------------------|----------------|
| Cakes and cookies | 3 and 5 |

Oven (Lower Oven)

Before using the racks

Each rack has stops that need to be placed correctly on the supports. These stops will keep the rack from coming completely out.

Removing the racks

1. Pull the rack straight out until it stops.
2. Lift up the front of the rack, and then pull it out.

Replacing the racks

1. Place the end of the rack on the support.
2. Tilt the front end up and push the rack in.

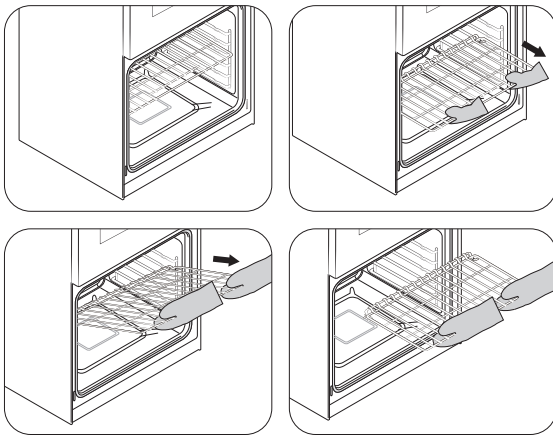

CAUTION

- Do not cover a rack with aluminum foil or place aluminum foil on the oven bottom. This will hamper heat circulation, resulting in poor baking, and may damage the oven bottom.
- Arrange the oven racks only when the oven is cool.

Using the gliding rack

The fully extendable Gliding rack makes food preparation easier, especially when you are preparing heavier dishes. The Gliding rack has 2 glide tracks that allow you to extend the rack well out of the oven without touching the sides of the oven walls.

Installing the gliding rack

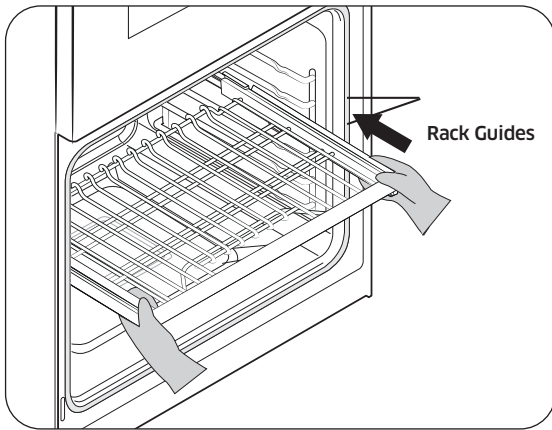

- With the Gliding rack in the Closed position and the oven off, carefully insert the Gliding Rack between the guides until the rack reaches the back.

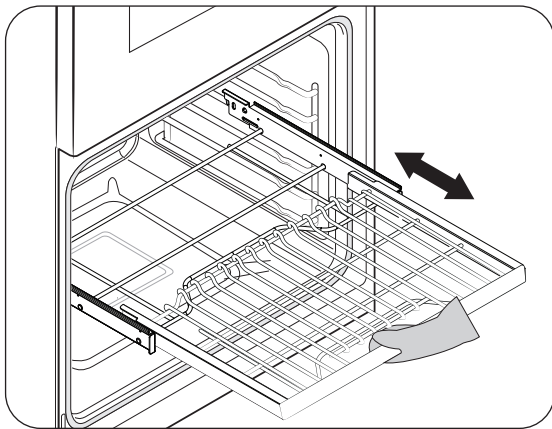

- When using the Gliding rack in the oven, be sure to pull on the handle of the rack only to slide it in and out. If you grasp the frame while using the rack, the entire Gliding rack will be removed. Make sure you use oven mitts when handling the Gliding rack during cooking.

Oven (Lower Oven)

Removing the gliding rack

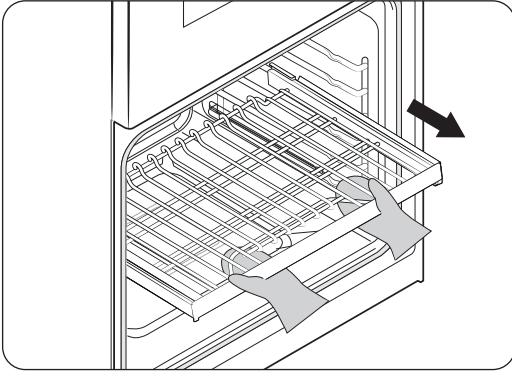

- With the Gliding rack in the Closed position and the oven off and cool, grasp the rack and frame and pull both forward to remove.

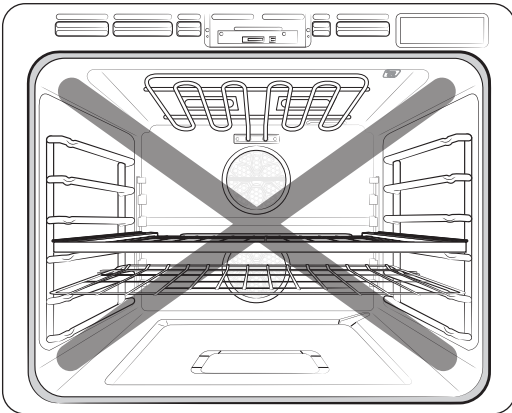

CAUTION

Do not install the Gliding rack directly above the Wire rack. You will not be able to install it properly and the rack could fall.

NOTE

You can install the Gliding rack in any rack positions except the lowest rack position in the oven (level 1).

Using the clean feature

The Clean feature has four selections: Self-Clean, GreenClean™, Descale, and Draining.

Self clean

This self-cleaning oven uses high temperatures (well above cooking temperatures) to burn off leftover grease and residue completely or reduce them to a finely powdered ash that you can wipe away with a damp cloth.

CAUTION

- During the self-cleaning cycle, the outside of the oven will become very hot to the touch. **Do not** leave small children unattended near the appliance.
- Some birds are extremely sensitive to the fumes given off during the self-cleaning cycle of any oven. Move birds to another well-ventilated room.
- **Do not** line the oven walls, racks, bottom, or any other part of the oven with aluminum foil. Doing so will result in poor heat distribution, poor baking results, and cause permanent damage to the oven interior. Aluminum foil will melt and adhere to the interior surface of the oven.
- The oven door locks during self-cleaning. **Do not** force the oven door open. This can damage the automatic door-locking system. Use care when opening the oven door after the self-cleaning cycle is complete. Stand to the side of the oven when opening the door to allow hot air or steam to escape. The oven may still be **VERY HOT**.

Oven (Lower Oven)

Before a self-cleaning cycle

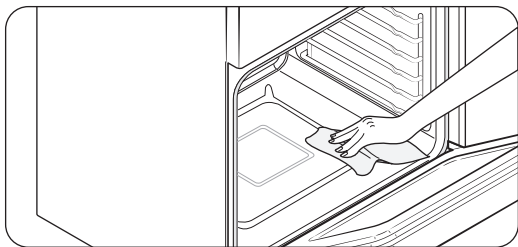

Fig. 1

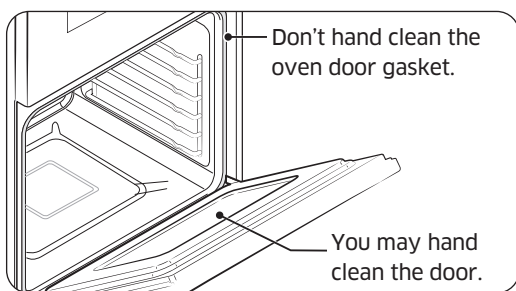
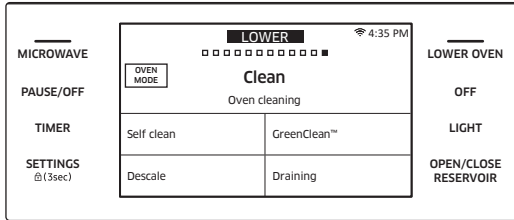

Fig. 2

- We recommend venting your kitchen with an open window or using a ventilation fan or hood during the self-cleaning cycle.
- Remove the wire rack, broil pan, broil pan insert, all cookware, and any aluminum foil from the oven.
- Wipe up debris from the oven bottom. (Fig. 1)
- The silver-colored oven racks can be self-cleaned, but they will darken, lose their luster, and become hard to slide.
- Residue on the front frame of the oven and outside the gasket on the door will need to be cleaned by hand. Clean these areas with hot water, soap-filled steel-wool pads, or cleansers such as Soft Scrub. Rinse well with clean water and dry.
- Do not clean the gasket. The fiberglass material of the oven door gasket cannot withstand abrasion. It is essential for the gasket to remain intact. If you notice it becoming worn or frayed, have it replaced. (Fig. 2)
- Make sure the oven light cover is in place and the oven light is off.

How to run a self-cleaning cycle



1. Tap **LOWER OVEN** and swipe the screen to **Clean**. The display will show 4 cleaning selections.

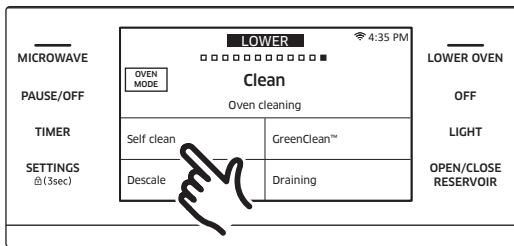

2. Tap **Self Clean**.

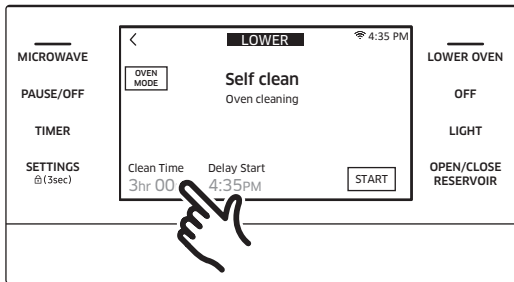

3. Tap **Clean Time**.

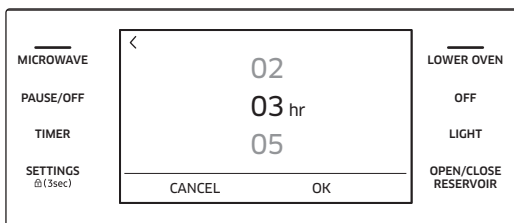

4. Slide the screen to set the clean time. You can choose 2 hours, 3 hours, or 5 hours. (The default is 3h).
5. Tap **OK**.



6. If you do not want to use the **Delay Start** feature, go to Step 8. Otherwise, tap **Delay Start**, and then go to Step 7.

Oven (Lower Oven)



7. Set the time you want self-cleaning to start, and then tap **OK**.

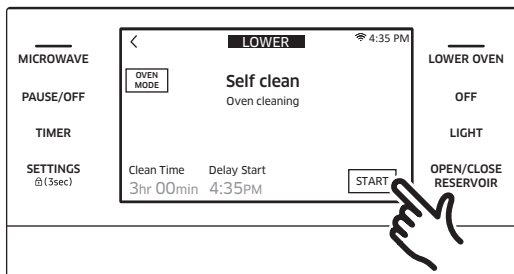

8. Tap **START** to begin self-cleaning. The motor-driven door lock will engage automatically.
Important: Only lower oven door locks when you run a self cleaning cycle on the lower oven.

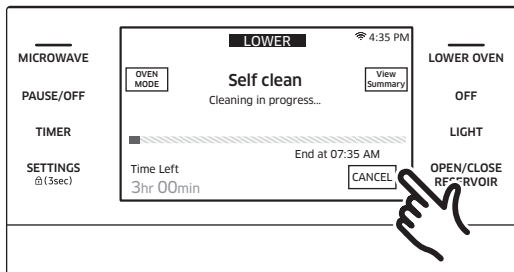

9. If you need to stop or interrupt a self cleaning cycle, tap **CANCEL**.

NOTE

- You will not be able to start a self-cleaning cycle if the control lockout feature is activated or if the oven's temperature is too hot.
- The oven doors lock automatically. The display will show the cleaning time remaining. You cannot open the oven doors until the temperature drops to a safe/cool temperature.
- The self-clean feature can be used in only one oven at a time. While one oven is in self-cleaning mode, you cannot use the other oven for cooking.

After a self-cleaning cycle

- You may notice some white ash in the oven. Wipe it up with a damp cloth after the oven cools. (If white spots remain, remove them with a soap-filled steel wool pad and rinse thoroughly with a vinegar and water mixture.)
- If the oven is not clean after one cycle, repeat the cycle.
- You cannot set the oven for cooking until the oven is cool enough for the door to unlock.

GreenClean™

The Green cleaning function saves time and energy by removing leftover grease and residue that you can wipe away with a damp cloth.

CAUTION

- **Do not** line the oven walls, racks, bottom, or any other part of the oven with aluminum foil. Doing so will result in poor heat distribution, poor baking results, and cause permanent damage to the oven interior. Aluminum foil will melt and adhere to the interior surface of the oven.
- The oven door locks during Green cleaning. **Do not** force the oven door open. This can damage the automatic door locking system. Use care when opening the oven door after a Green cleaning cycle is complete. Stand to the side of the oven when opening the door to allow hot air or steam to escape.

Oven (Lower Oven)

Before a green cleaning cycle

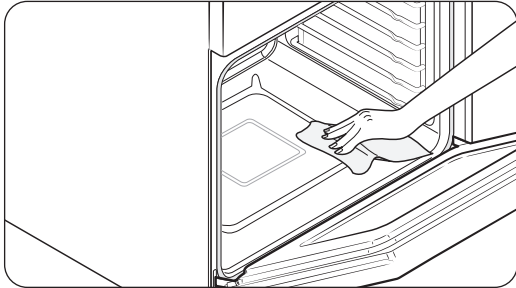

Fig. 1



Fig. 2

- Remove the wire rack, broil pan, broil pan insert, all cookware, and any aluminum foil from the oven.
- Wipe up debris from the oven bottom. (Fig. 1)
- The silver-colored oven racks can be Green cleaned, but they will darken, lose their luster, and become harder to slide.
- Residue on the front frame of the oven and outside the gasket on the door will need to be cleaned by hand. Clean these areas with hot water, soap-filled steel-wool pads, or cleansers such as Soft Scrub. Rinse well with clean water and dry.
- Do not clean the gasket. The fiberglass material of the oven door gasket cannot withstand abrasion. It is essential for the gasket to remain intact. If you notice it becoming worn or frayed, have it replaced. (Fig. 2)
- Make sure the oven light cover is in place and the oven light is off.

NOTE

Remove oven racks and accessories before starting the GreenClean™ mode.

How to run a green-cleaning cycle

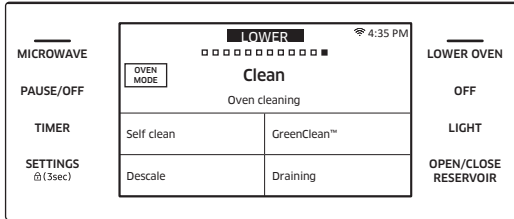

1. Tap **LOWER OVEN** and swipe the screen to **Clean**. The display will show 4 cleaning selections.

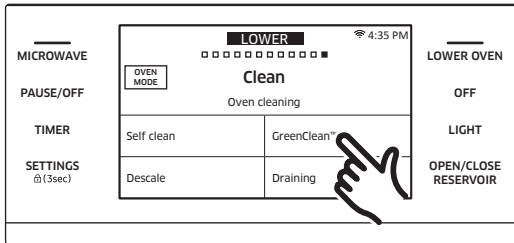

2. Tap **GreenClean™**.

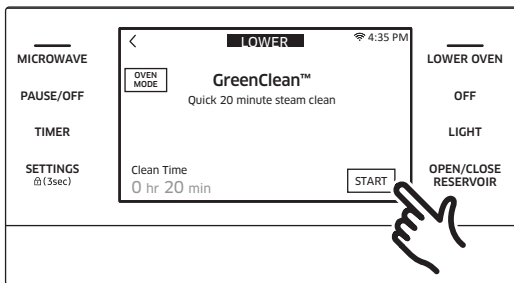

3. Tap **START** to begin Green cleaning.

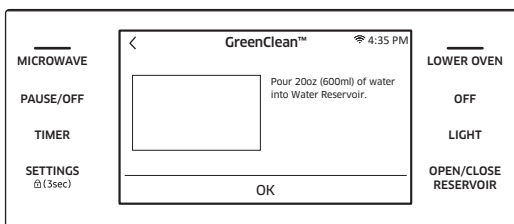

4. Follow the on-screen instructions. Green cleaning will start automatically.

NOTE

Lower oven door is locked during Green cleaning.

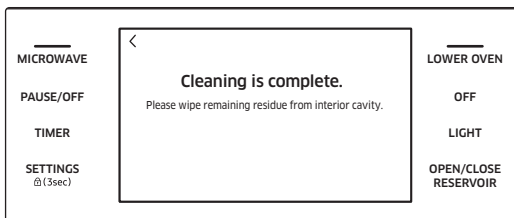

5. When Green cleaning is complete, clean the oven's interior. There will be a significant amount of water remaining on the bottom of the oven after a Green cleaning cycle. Remove the residual water with a sponge or soft dry cloth.

Oven (Lower Oven)

NOTE

For Green cleaning, use exactly 10 oz (300 ml) of water since this produces the best results.

After a green cleaning cycle

- Take care when opening the door after a Green cleaning procedure has ended. The water on the bottom is hot.
- Open the oven door and remove the remaining water with a sponge. Do not leave the residual water in the oven for any length of time. Wipe the oven clean and dry with a soft cloth. Do not forget to wipe under the oven door seal.
- Use a detergent-soaked sponge, a soft brush, or a nylon scrubber to wipe the oven interior. Remove stubborn residue with a nylon scourer. You can remove lime deposits with a cloth soaked in vinegar.
- If the oven remains dirty, you can repeat the procedure once the oven has cooled.
- For heavy residue, such as grease left over from roasting, we recommend that you rub detergent into the residue before activating the Green cleaning function.
- After cleaning, leave the oven door open at a 15° angle to allow the interior enamel surface to dry thoroughly.

NOTE

- You will not be able to start a Green cleaning cycle if the Control Lockout feature is activated or if the oven's temperature is too hot.
- The oven door locks automatically. The display will show the cleaning time remaining. You cannot open the Lower oven door until the temperature drops to a safe/cool temperature.
- The Green clean feature can be used in only Lower oven. While Lower oven is in Green cleaning mode, you cannot use Microwave oven for cooking.
- If the oven is not clean after one cycle, repeat the cycle.
- You cannot set the oven for cooking until the oven is cool enough for the door to unlock.

Descale

If you use Steam Bake or Steam Roast functions frequently, we recommend descaling regularly to remove minerals from the oven that may affect the taste or quality of food cooked. When running a descaling cycle, use only descaling agents that are specific to steam ovens or coffee machines.

NOTE

If you use Steam Bake or Steam Roast functions for more than a total of 12 hours, the Descal indicator turns on. You can still enable the Steam Bake or Steam Roast functions for the next two hours without descaling. However, after those two hours are up, the Steam Bake or Steam Roast functions will be disabled until you run a descaling cycle.

How to run a descale cycle

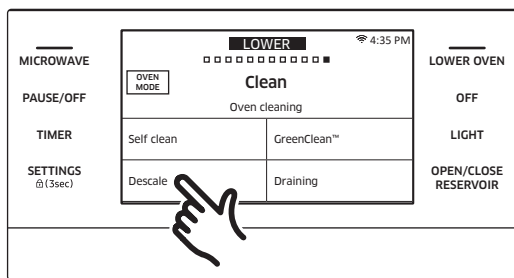

1. Tap **LOWER OVEN** and swipe the screen to **Clean**. The display will show 4 cleaning selections.
2. Tap **Descal**.

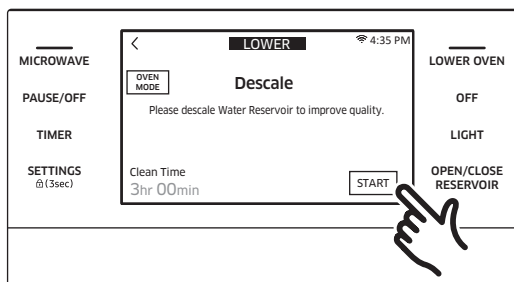

3. Tap **START**.

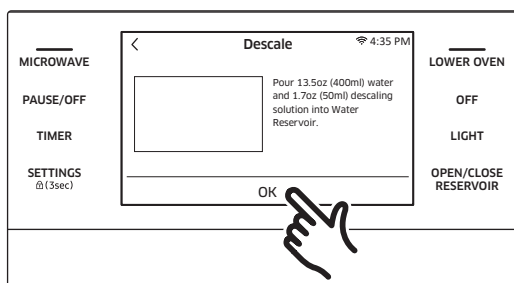

4. Follow the on-screen instructions. It takes 3 hours to complete the cycle.
 - Empty and clean the water reservoir, and then fill it with 1.7 oz (50 ml) of descaling agent and 13.5 oz (400 ml) of tap water.

Oven (Lower Oven)

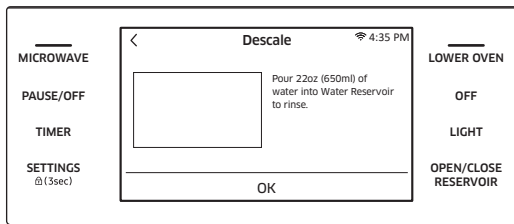
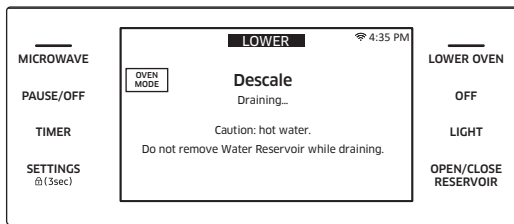

- When descaling is complete, the oven drains water automatically.
- Use oven mitts to remove and empty the water reservoir, and then refill it with 22 oz (650 ml) of tap water for rinsing.
- Follow the on-screen instructions, and then tap **OK** to start rinsing.
- When rinsing is complete, use oven mitts to empty and clean the water reservoir.

WARNING

Use only descaling agents that are specific to steam ovens or coffee machines.

CAUTION

- Running the Descaling function disables Steam Bake and Steam Roast. Do not cancel descaling while it is in process. If you stop it, you must restart the descaling cycle and complete it within the next three hours to re-enable the Steam Bake and Steam Roast functions.
- To avoid accidents, keep children away from the oven.
- For the correct ratio of water and the descaling agent, follow the agent manufacturer's instructions. If the ratio of water to descaling agent differs from the instructions here (8 to 1), use the ratio indicated in the instructions for the descaling agent.

NOTE

Although the oven automatically starts descaling in 5 seconds without your confirmation, we recommend that you confirm your selection. This is to prevent descaling from starting by mistake.

Draining

When a steam function is complete, you must drain the remaining water to prevent the water from affecting other cooking modes.

To drain the water, follow these steps:

How to drain the oven

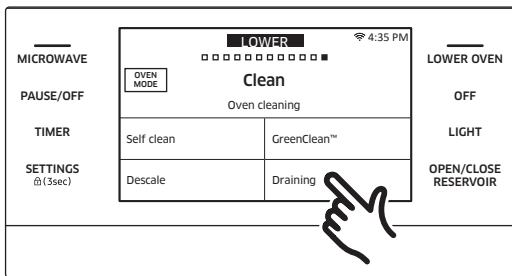

1. Tap **LOWER OVEN** and swipe the screen to Clean. The display will show 4 cleaning selections.
2. Tap **Draining**.

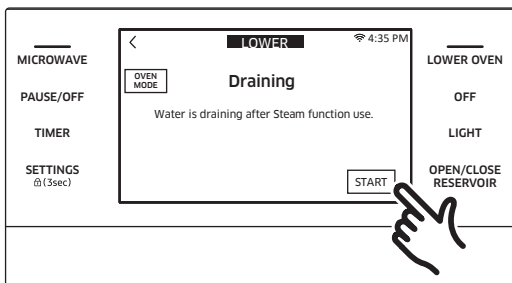

3. Tap **START**. The oven drains water from the steam generator to the water reservoir.

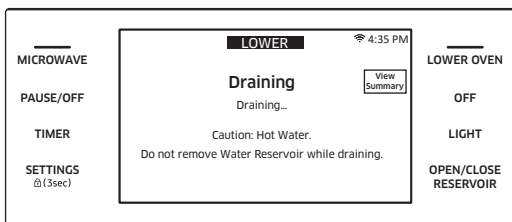

4. When draining is complete, use oven mitts to remove and empty the water reservoir.



NOTE

Once the oven starts draining, wait until the draining cycle is complete.

Oven (Lower Oven)

Settings

In Settings, you can change the default settings to your preference or diagnose problems with the network connection.

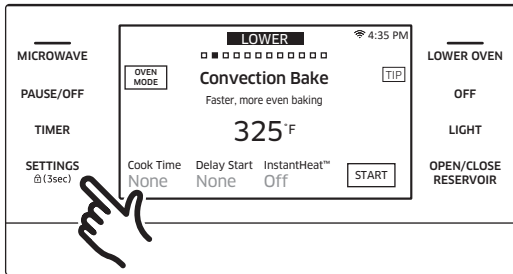

Touch **SETTINGS**. The display will show the Setting item.

Wi-Fi

To enable a Wi-Fi connection

1. Touch **SETTINGS** and then tap **Connections > Wi-Fi > ON**.
2. Tap **Wi-Fi**, and then tap a Wi-Fi network in the list that appears.
3. You will be prompted to provide a password for a secure network. Enter the password.

To manually input an IP

1. Touch **SETTINGS** and then tap **Wi-Fi > ON**.
2. Tap **Wi-Fi**, and then tap **Add Network**.
3. Enter an IP manually, and then tap **CONNECT** to apply your settings.

NOTE

- To disable a Wi-Fi connection, Touch **SETTINGS** and then tap **Wi-Fi > OFF**.
- For details about the Wi-Fi connection and using the SmartThings app, see the SmartThings app user manual.

iQ control

To start the oven remotely.

- Tap **SETTINGS > Connections > iQ Control**, and then tap **ON** of **LOWER** oven. (See the using the iQ control feature section on page 102.)

Easy connection

Easy connection enables you to easily configure the network settings including the authentication procedure.

Remote Management

The call center will access your product remotely to check internal when you have some problems.

Display

1. Brightness

You can change the brightness of the display screen.

- Touch **SETTINGS** and then tap **Display > Brightness**. Use the bar to adjust the brightness of the screen.

2. Screen saver

If screen saver is turned off, the Clock theme and Timeout menu are disabled.

- Touch **SETTINGS** and then tap **Display > Screen saver > OFF**.

3. Clock theme

- Touch **SETTINGS** and then tap **Display > Clock theme**. Slide the current setting to select a desired theme.

4. Timeout

- Touch **SETTINGS** and then tap **Display > Timeout**. Tap the current setting to select a desired time. You can select a time from 5 minutes to 60 minutes.

Date & Time

To enable automatic date and time

1. Turn on the Wi-Fi connection.
2. Touch **SETTINGS** and then tap **Date & Time**.
3. Tap **ON** in the right screen. The date and time are set automatically.

To manually input the date and time

1. Touch **SETTINGS** and then tap **Date & Time**.
2. Tap **OFF** in the right screen. Time zone, set date, and set time are activated.
3. You can set the time zone, date, and time.

To change the time format

1. Touch **SETTINGS** and then tap **Date & Time**. Tap the current setting to select a desired time format.
2. You can select 12-hour clock or 24-hour clock.

Oven (Lower Oven)

Language

Choose a display language.

1. Touch **SETTINGS** and then tap **Language**. Tap the current setting to select a desired language.
2. You can select English, Spanish, or French.

Volume

Adjust the volume level for beeps and melodies.

- Touch **SETTINGS** and scroll until **Volume** menu. Use the bar to adjust the volume.

Temp

1. Temp unit

You can program the oven control to display the temperature in Fahrenheit or Celsius. The oven has been preset at the factory to display in Fahrenheit.

- Touch **SETTINGS** and then tap **Temp > Temp unit**. Tap the current setting to select a desired unit.

2. Temp adjust

The temperature in the oven has been calibrated at the factory. When first using the oven, be sure to follow recipe times and temperatures.

If you think the oven is too hot or too cool, you can correct the temperature in the oven. Before correcting, test a recipe by using a temperature setting that is higher or lower than the recommended temperature.

The baking results should help you to decide how much of an adjustment is needed. The oven temperature can be adjusted ± 35 °F (± 19 °C).

- Touch **SETTINGS** and then tap **Temp > Temperature Adjust**. Tap the current setting. You can increase or decrease the temperature by 35 °F (19 °C).

NOTE

- This adjustment will not affect the broiling or the self-cleaning temperatures. The adjustment will be retained in memory after a power failure.

12-hour energy Saving

If you accidentally leave the oven on, this feature will automatically turn off the oven after 12 hours during baking functions or after 3 hours during a broil function.

1. Touch **SETTINGS** and then tap **12-hour energy Saving > ON**.
2. The 12-hour energy saving icon will appear in the indicator area.

Help

Help provides useful tips and explanations on a specific item that you select.

1. Troubleshooting
 - Tap a checkpoint directly on the screen, and then try the suggestions.
2. Guide for first use
 - Provides simple instructions on the basic use of the oven.

About device

You can see information about the oven and do a software update.

To update the software:

1. Touch **SETTINGS** and then tap **About device > SW update > Update**.
2. Tap **INSTALL**. The software is updated and the system restarts automatically.

Sabbath

You can set Sabbath mode. See the Using the Sabbath feature section on the next page.

Demo mode

This option is for use by retail establishments for display purposes only. (The heating element does not operate.)

1. Touch **SETTINGS** and then tap **Demo mode > ON**.
2. The Demo mode indicator appears on screen.

Oven (Lower Oven)

Using the Sabbath feature

(For use on the Jewish Sabbath & Holidays)



For further assistance, guidelines for proper usage, and a complete list of models with the Sabbath feature, visit the web at <http://www.star-k.org>.

You can use the Sabbath feature with baking only. The oven temperature may be set higher or lower after you set the Sabbath feature. (The oven temperature adjustment feature should be used only during Jewish holidays.) The display, however, will not change and tones will not sound when a change occurs. Once the oven is properly set for baking with the Sabbath feature active, the oven will remain on continuously until the Sabbath feature is canceled. This will override the factory preset 12-hour energy saving feature. If the oven light is needed during the Sabbath, touch **LIGHT** before activating the Sabbath feature. Once the oven light is turned on and the Sabbath feature is active, the oven light will remain on until the Sabbath feature is turned off. If the oven light needs to be off, be sure to turn the oven light off before activating the Sabbath feature.

How to use the Sabbath feature

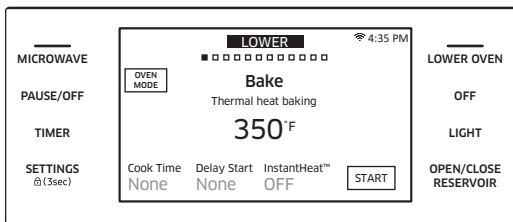

1. Tap **LOWER OVEN** and swipe the screen to Bake mode.



2. Set the temperature and cook time you want.
3. Tap **START**.

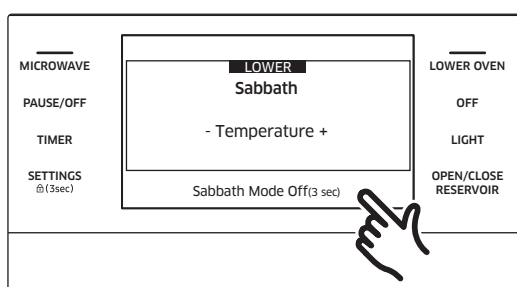
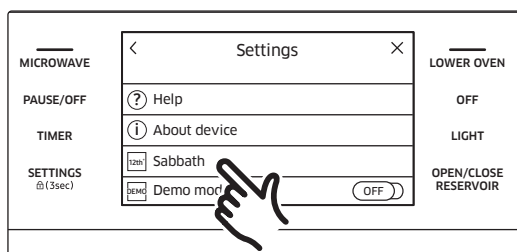

4. Touch **SETTINGS** and then tap **Sabbath** to use the Sabbath feature. The oven will not beep or display any further changes. You may change the oven temperature once baking has started. Remember that the oven will not beep or display any further changes once the Sabbath feature is engaged.
5. You can turn the oven off at any time by tapping **OFF**. Note that this method does not turn Sabbath mode off.
6. To turn Sabbath mode off, tap and hold **Sabbath Mode Off** for 3 seconds. Note that this turns the oven off too.

⚠ CAUTION

- Do not attempt to activate any other program feature except Bake while the Sabbath feature is active.
- Do not open the oven door or change the oven temperature for about 30 minutes after you have started Sabbath mode to allow the oven to reach the set temperature. Note that for best performance, the oven fan operates only when the oven temperature is rising.

📖 NOTE

- You can change the oven temperature, but the display will not change and tones will not sound when a change occurs. After you change the temperature while the unit is in Sabbath mode, there is a 15 second delay before the unit recognizes the change.
- You can set the **Cook Time** function before activating the Sabbath feature.
- Should you experience a power failure or interruption, the oven will shut off. When power is returned, the oven will not turn back on automatically. **Sabbath** will be displayed in the oven control display, but the oven will not operate. Food may be safely removed from the oven while it is still in the Sabbath mode, however the oven cannot be turned back on until after the Sabbath Holidays. After the Sabbath observance, turn off the Sabbath mode.
- Tap and hold **Sabbath Mode Off** for 3 seconds.

Maintaining your appliance

Care and cleaning of the oven

Cleaning painted parts and decorative trim

- For general cleaning, use a cloth with hot, soapy water.
- For more difficult residue and built-up grease, apply a liquid detergent directly onto the area and leave for 30 to 60 minutes. Wipe with a damp cloth and dry. Do not use abrasive cleaners on any oven surfaces. They can be scratched.

Cleaning stainless-steel surfaces

1. Shake a bottle of stainless-steel appliance cleaner/polish.
2. Place a small amount of the cleaner/polish on a damp cloth or damp paper towel.
3. Clean a small area, rubbing with the grain of the stainless steel if applicable.
4. Dry and buff with a clean, dry paper towel or soft cloth.
5. Repeat as necessary.

NOTE

- **Do not use a steel-wool pad. It will scratch the surface.**
- If a mineral-oil-based, stainless-steel-appliance cleaner has been used before to clean the appliance, wash the surface with dishwashing liquid and water before using the stainless steel appliance cleaner/polish.

Oven racks

- If the racks are left in the oven during a self-cleaning cycle, their color will turn slightly blue and the finish will be dull. After the self-cleaning cycle is complete and the oven has cooled, rub the sides of the racks with wax paper or a cloth containing a small amount of oil. This will help the racks glide more easily on their tracks.
- Gliding racks may be cleaned by hand with an abrasive cleaner or steel wool. During cleaning, be careful not to allow water or cleaner to enter the slides on the sides of rack.

NOTE

- Do not clean in a dishwasher.
- If the rack becomes hard to remove or replace, lightly wipe the oven rack guides with cooking oil. Do not wipe cooking oil on the slides.
- If the rack becomes difficult to slide, the rack may need to be lubricated using a graphite lubricant.

NOTE

- To order graphite lubricant, call Dacor Customer Service at 833-353-5483 or visit our homepage (<http://www.dacor.com/Customer-Care/Service-Parts>) and search for part number DG81-01629A..

Maintaining your appliance

To lubricate the slides of the gliding rack

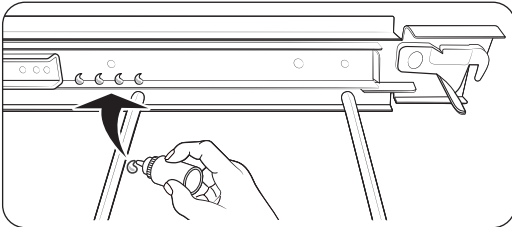
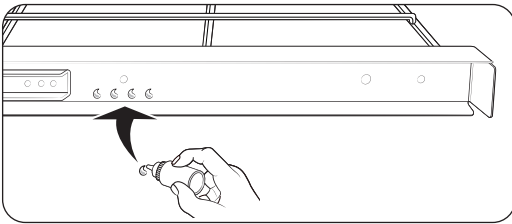
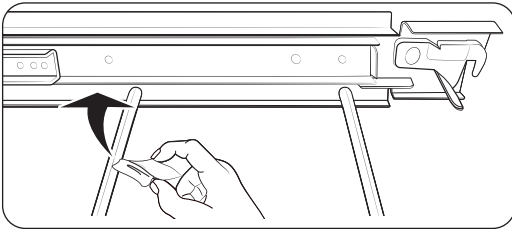
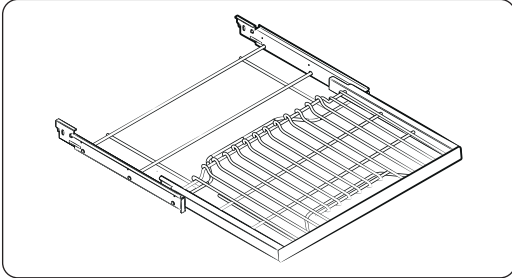

1. Remove the rack from the oven. See removing the gliding rack in the Using the gliding rack section on page 107.
2. Fully extend the rack on a table or countertop. Newspaper may be placed underneath the rack for easy cleanup.
3. If there is debris in the slide tracks, wipe it away using a paper towel. (Any graphite lubricant wiped away must be replaced - See steps 4 through 7.
4. Shake the graphite lubricant before opening it. Starting with the left (front and back) slide mechanism of the rack, place four (4) small drops of lubricant on the two (2) bottom tracks of the slide close to the bearing carriers.

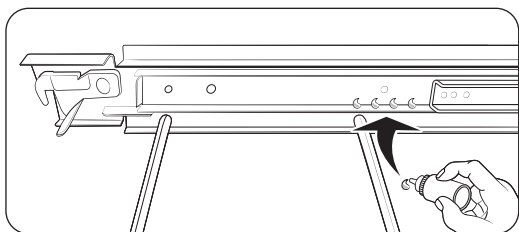
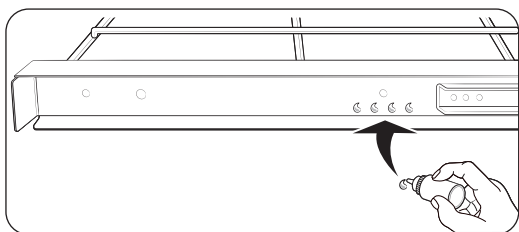

5. Repeat for the right (front and back) slide mechanism of the rack.
6. Open and close the rack several times to distribute the lubricant.
7. Replace the cap on the lubricant and shake it again. Turn the rack over and repeat steps 3, 4, 5, and 6.
8. Close the rack, turn the rack right-side up, and slide it into the oven. See Installing the gliding rack on page 107.

 **NOTE**

Do not spray the gliding rack with cooking spray or other lubricant sprays.

Oven door



- Use soap and water to thoroughly clean the top, sides, and front of the oven door. Rinse well. You may use a glass cleaner on the outside glass of the oven door. **DO NOT immerse the door in water. DO NOT spray or allow water or the glass cleaner to enter the door vents.** DO NOT use oven cleaners, cleaning powders, or any harsh abrasive cleaning materials on the outside of the oven door.
- **DO NOT clean the oven-door gasket.** The oven-door gasket is made of a woven material which is essential for a good seal. Care should be taken not to rub, damage, or remove this gasket.

Maintaining your appliance

Removing the oven door (Lower oven only)

⚠ CAUTION

- The door is very heavy. Be careful when removing and lifting the door.
- Do not lift the door by the handle.
Use two hands to remove the oven door.

⚠ WARNING

For safety reasons, you cannot remove the door of the upper oven.

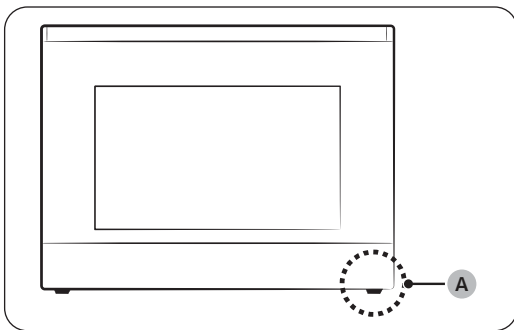

A. Wire Harness

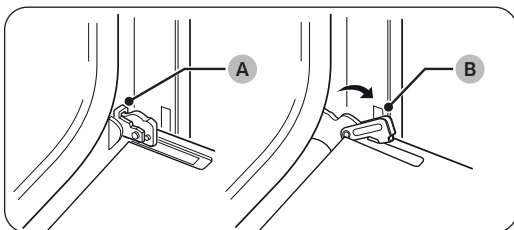
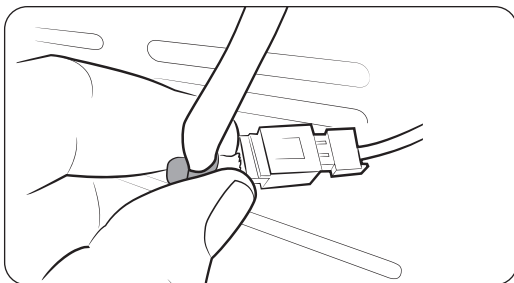

- A. Oven-door hinge lock in locked position
B. Oven-door hinge lock in unlocked position

1. Prior to removing the oven door, prepare a surface where you will place it. This surface should be flat and covered with a soft blanket. You can also use the corner posts from your packaging material.
2. Disconnect the LED light's Wire Harness from the bottom right of the door.
3. Open the oven door.
4. Locate the oven-door hinge locks in both corners of the oven door, and then rotate the hinge locks toward the oven door to the unlocked position. If the door hinge lock is not rotated fully (see illustration B on the left for an example of full rotation), you will not be able to remove the door properly.

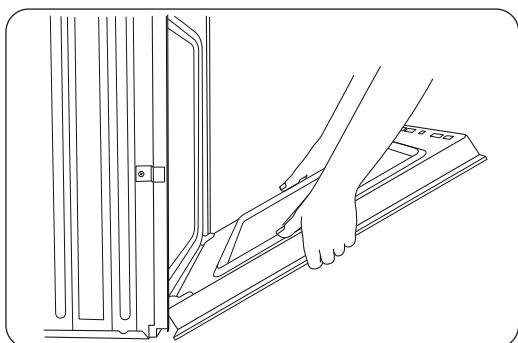

5. Partially close the door to engage the door latch locks. The door will stop at this point.

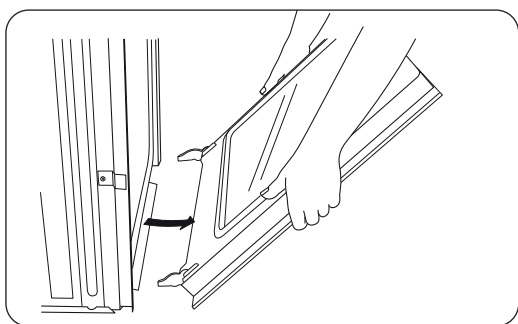

6. Using two hands, grasp the sides of the oven door. Lift and pull the oven door toward you and remove. You may need to gently shift the door from side to side as you pull.
7. Set the oven door aside on the prepared covered work surface with the oven door resting on its handle.

Maintaining your appliance

Replacing the oven door (Lower oven only)

CAUTION

The door is very heavy. You may need help lifting the door high enough to slide it into the hinge slots. Do not lift the door by the handle.

WARNING

You cannot replace the upper oven door for safety reason.

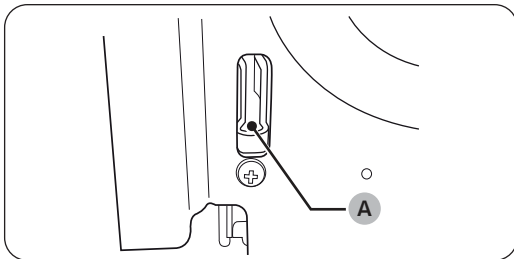

A. Slot in the oven cavity for the door hinge lock

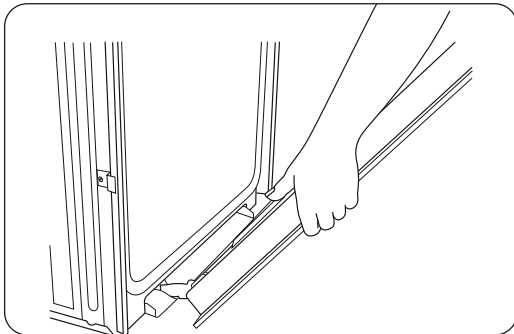

1. Using two hands, grasp the side edges of the door at the midpoint. Face the oven cavity.
2. Locate the slots on each side of the oven cavity for the door hinge locks.
3. Hold the door at a 45° angle, and then align the door hinges with the slots in the lower front of the oven cavity. Slowly insert the door, making sure you maintain the 45° angle. You will know the door is engaged in the slot when you feel a slight drop.

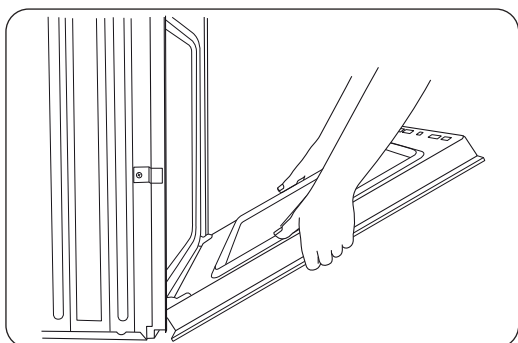

4. Lower the oven door to the fully open position. If the oven door does not open to a full 90°, repeat steps 1 through 3.
5. Locate the oven-door hinge locks in the corners of the oven door, and rotate the hinge locks toward the oven cavity to the locked position. See Step 3 (**illustration A**) in the "Removing the oven door" section for the proper locked position.
6. Close the oven door.
7. When the hinges are properly installed and the door is closed, there should be an even gap between the door and the control panel. If one side of the oven door is hanging lower than the other, the hinge on that side is not properly installed.
8. Reconnect the LED light's Wire Harness.

⚠ CAUTION

After replacing the door, make sure to reconnect the wires. Push them inward to arrange them as they were before you removed the door. Wires that are not connected or arranged correctly can be caught in the door or damaged by heat.

Maintaining your appliance

Changing the oven light (Lower oven only)

The oven light is a standard 40-watt-appliance halogen bulb. It comes on when the oven door is open. When the oven door is closed, touch **LIGHT** to turn the light on or off. It will not work during a self-cleaning or Green cleaning cycle.

CAUTION

Before changing the oven light, make sure to wear gloves to protect your hands.

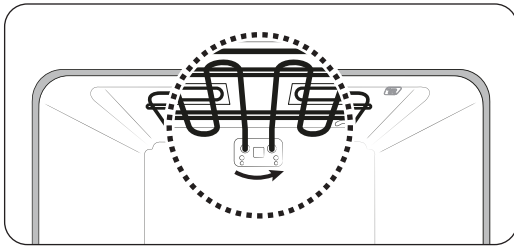

1. To change the halogen bulb, you must tilt the broil heater down. To do this, turn the circular nut on the support counterclockwise while holding the broil heater. The broil heater should loosen and tilt down.

CAUTION

The broil heater is not a removable part. Do not force the broil heater down. Do not let it drop down.

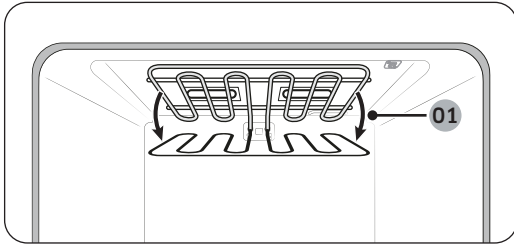

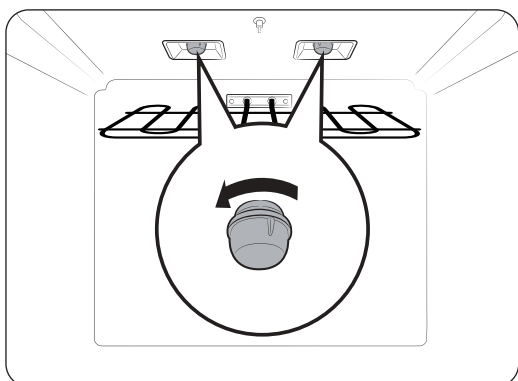
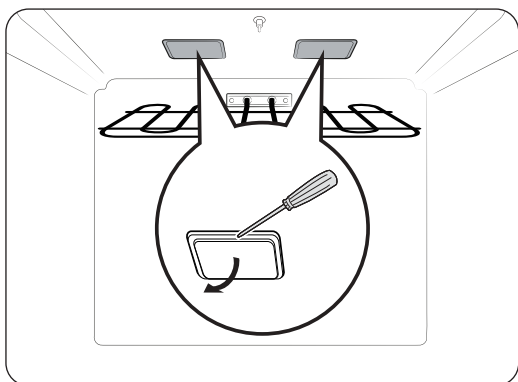

2. While holding the glass cover with one hand, insert a flat-sharp tool such as a table knife between the glass and the frame to remove the glass cover.

3. Turn the bulb cap counterclockwise to remove.

 **NOTE**

If necessary, remove the metal rings and clean the bulb cap.

4. Replace the bulb.
5. Place the bulb cap and glass cover back into their position.
6. Return the broil heater back by following step 1 in reverse order.

 **CAUTION**

Before changing your oven light, disconnect the electrical power to the oven at the main fuse or circuit breaker panel. Make sure the oven and the halogen bulb are cool.

Troubleshooting

If you experience malfunctions or performance issues, review the tables in this section to resolve the issue yourself. If you still cannot resolve the issue, call Dacor Customer Service 833-353-5483(USA), 844-509-4659(Canada).

Control display

| Problem | Possible cause | Solution |
|---|--|---|
| The display goes blank. | A fuse in your home may be blown or the circuit breaker tripped. | Replace the fuse or reset the circuit breaker. |
| Touch-controls do not respond to touch. | <ul style="list-style-type: none"> • Touch model: There is moisture on the exterior • The lock function is set | <ul style="list-style-type: none"> • Remove the moisture and try again. • Check whether the lock function is set. |

For the microwave oven

| Symptom | Cause | Action |
|---|--|--|
| General | | |
| Touch-controls do not respond to touch. | For touch models: Moisture is on the exterior. | Wipe the moisture from the exterior. |
| | Child lock is activated. | Deactivate Child lock. |
| The oven does not work. | Power is not supplied. | Make sure power is supplied. Make sure the oven is plugged in. Check if a fuse has been blown or circuit breaker has been tripped. |
| | The door is open. | Close the door and try again. |
| | The door-open safety mechanisms are covered in foreign matter. | Remove the foreign matter and try again. |
| The oven stops while in operation. | The user has opened the door to turn food over. | After turning over the food, press the Start button again to start operation. |

| Symptom | Cause | Action |
|--|---|--|
| The power turns off during operation. | The oven has been cooking for an extended period of time. | After cooking for an extended period of time, let the oven cool. |
| | The cooling fan is not working. | Listen for the sound of the cooling fan. |
| | Trying to operate the oven without food inside. | Put food in the oven. |
| | There is insufficient ventilation space for the oven. | There are intake/exhaust outlets on the front and rear of the oven for ventilation. Keep the gaps specified in the product installation guide. |
| | Several power plugs are being used in the same socket. | Designate only one socket to be used for the oven. |
| There is a popping sound during operation, and the oven does not work. | Cooking sealed food or using a container with a lid may cause popping sounds. | Do not use sealed containers as they may burst during cooking due to expansion of the contents. |
| The oven exterior is too hot during operation. | There is insufficient ventilation space for the oven. | There are intake/exhaust outlets on the front and rear of the oven for ventilation. Keep the gaps specified in the product installation guide. |
| | Objects are on top of the oven. | Remove all objects on the top of the oven. |
| The door cannot be opened properly. | Food residue is stuck between the door and oven interior. | Clean the oven and then open the door. |
| Heating including the Warm function does not work properly. | The oven may not work, too much food is being cooked, or improper cookware is being used. | Put one cup of water in a microwave-safe container and run the microwave for 1-2 minutes to check whether the water is heated. Reduce the amount of food and start the function again. Use a cooking container with a flat bottom. |
| The thaw function does not work. | Too much food is being thawed. | Reduce the amount of food and start the function again. |

Troubleshooting

| Symptom | Cause | Action |
|--|---|--|
| The interior light is dim or does not turn on. | The door has been left open for a long time. | The interior light may automatically turn off when the Eco function operates. Close and reopen the door or press the CANCEL button. |
| | The interior light is covered by foreign matter. | Clean the inside of the oven and check again. |
| A beeping sound occurs during cooking. | If the Auto Cook function is being used, this beeping sound means it's time to turn over the food during thawing. | After turning over the food, press the START button again to restart operation. |
| The oven is not level. | The oven is installed on an uneven surface. | Make sure the oven is installed on flat, stable surface. |
| There are sparks during cooking. | Metal containers are used during oven/thawing functions. | Do not use metal containers. |
| When power is connected, the oven immediately starts to work. | The door is not properly closed. | Close the door and check again. |
| There is electricity coming from the oven. | The power or power socket is not properly grounded. | Make sure the power and power socket are properly grounded. |
| Water drips. Steam is emitted through a door crack. Water remains in the oven. | There may be water or steam in some cases depending on the food. This is not an oven malfunction. | Let the oven cool and then wipe with a dry dish towel. |
| The brightness inside the oven varies. | Brightness changes depending on power output changes according to function. | Power output changes during cooking are not malfunctions. |
| Cooking is finished, but the cooling fan is still running. | To ventilate the oven, the cooling fan continues to run for about 3 minutes after cooking is complete. | This is not an oven malfunction. |

| Symptom | Cause | Action |
|--|--|--|
| Optitray | | |
| While turning, the optitray comes out of place or stops turning. | There is no roller ring, or the roller ring is not properly in place. | Install the roller ring and then try again. |
| The turn table drags while turning. | The roller ring is not properly in place, there is too much food, or the container is too large and touches the inside of the microwave. | Adjust the amount of food. Do not use containers that are too large. |
| The turn table rattles while turning and is noisy. | Food residue is stuck to the bottom of the oven. | Remove any food residue stuck to the bottom of the oven. |
| Broiling | | |
| Smoke comes out during operation. | During initial operation, smoke may come from the heating elements when you first use the oven. | This is not a malfunction. After you run the oven 2-3 times, it should stop. |
| | Food is on the heating elements. | Let the oven cool and then remove the food from the heating elements. |
| | Food is too close to the grill. | Put the food a suitable distance away while cooking. |
| | Food is not properly prepared and/or arranged. | Make sure food is properly prepared and arranged. |
| Convection | | |
| The oven does not heat. | The door is open. | Close the door and try again. |
| Smoke comes out during preheating. | During initial operation, smoke may come from the heating elements when you first use the oven. | This is not a malfunction. After you run the oven 2-3 times, it should stop. |
| | Food is on the heating elements. | Let the oven cool and then remove the food from the heating elements. |

Troubleshooting

| Symptom | Cause | Action |
|--|---|--|
| There is a burning or plastic smell when using the oven. | Plastic or non-heat-resistant cookware is used. | Use glass cookware suitable for high temperatures. |
| There is a bad smell coming from inside the oven. | Food residue or plastic has melted and stuck to the interior. | Run the Steam Bake function for an hour, and then wipe with a dry cloth. You can put a lemon slice inside, and then run Steam Bake to remove the odor more quickly. |
| The oven does not cook properly. | The oven door is frequently opened during cooking. | If you open the door often, the interior temperature will be lowered and this may affect the results of your cooking. |
| | The oven controls are not correctly set. | Correctly set the oven controls and try again. |
| | The broil heater or other accessories are not correctly inserted. | Correctly insert the accessories. |
| | The wrong size or wrong type of cookware is used. | Use suitable cookware with flat bottoms. |

For the lower oven

| Problem | Possible cause | Solution |
|--|---|--|
| The oven will not turn on. | The oven is not completely plugged into the electrical outlet. | Make sure the electrical plug is inserted into a live, properly grounded outlet. |
| | A fuse in your home may be blown or a circuit breaker may have tripped. | Replace the fuse or reset the circuit breaker. |
| | The oven controls have been set improperly. | See the Basic operations section starting on page 30 . |
| | The oven is too hot. | Allow the oven to cool. |
| | Incomplete service wiring. | Call for service. |
| | Power outage. | Check to see if the house lights will turn on. If necessary, call your local electric company for service. |
| The oven light will not turn on. | The light is loose or defective. | Tighten or replace the lamp. Call for service if the door light does not turn on. |
| | The switch operating the light is broken. | Call for service. |
| The oven smokes excessively during broiling. | The oven controls have not been set properly. | See the Basic operations section starting on page 30 . |
| | The meat has been placed too close to the element. | Reposition the rack to provide proper clearance between the meat and the element. Preheat the broil element for searing. |
| | The meat has not been properly prepared. | Remove excess fat from the meat. Cut away fatty edges that may curl, leaving the lean intact. |
| | Grease has built up on oven surfaces. | Regular cleaning is necessary when broiling frequently. |

Troubleshooting

| Problem | Possible cause | Solution |
|---|--|--|
| Food does not bake or roast properly. | The oven controls have not been set correctly. | See the Basic operations section starting on page 30. |
| | The oven rack has been positioned incorrectly or is not level. | See the Using the oven racks section on page 104. |
| | The oven thermistor needs to be adjusted. | See Temp adjust in the Settings section on page 122. |
| Food does not broil properly. | The serving size may not be appropriate. | Refer to the Broiling recommendation guide for serving sizes on page 92, and then try again. |
| | The rack has not been properly positioned. | See the Broiling recommendation guide on page 92. |
| | The cookware is not suited for broiling. | Use suitable cookware. |
| | In some areas, the power (voltage) may be low. | Preheat the broil element for 10 minutes. See the Broiling recommendation guide on page 92. |
| The oven temperature is too hot or too cold. | The oven thermistor needs to be adjusted. | See Temp adjust in the Settings section on page 122. |
| There is water dripping. | You may see water or steam in some cases depending on the food you are cooking. This is not a product malfunction. | Let the oven cool and then wipe with a dry dish towel. |
| There is steam coming through the crack between the oven body and the door. | | |
| Water remains in the oven. | | |
| I can hear water boiling during steam cooking. | Water is being heated by the steam heater. | This is not a product malfunction. |

| Problem | Possible cause | Solution |
|--|---|--|
| The oven will not self-clean. | The oven temperature is too high to start a self-clean operation. | Allow the oven to cool and then reset the controls. |
| | The oven controls have been set incorrectly. | See the Self clean section on page 111 . |
| | A self-cleaning cycle cannot be started if the oven lockout feature has been activated. | Deactivate the oven control lockout (see page 33). |
| Excessive smoking during a self-cleaning cycle. | There is excessive soiling in the oven. | Press OFF . Open the windows to rid the room of smoke. Wait until the self-cleaning cycle is canceled. Wipe up the excessive soil and then start the self-cleaning cycle again. |
| The oven door will not open after a self-cleaning cycle. | The oven is too hot. | Allow the oven to cool. |
| The oven is not clean after a self-cleaning cycle. | The oven controls were not set correctly. | See the Self clean section on page 111 . |
| | The oven was heavily soiled. | Wipe up heavy spillovers before starting the self-cleaning cycle. Heavily soiled ovens may need to be self-cleaned again or for a longer period of time. |
| Steam is coming out of the vent. | When using the convection feature, it is normal to see steam coming out of the oven vent. | This is normal operation and not a system failure. Use the oven as usual. |
| | As the number of racks or amount of food being cooked increases, the amount of visible steam will increase. | |
| A burning or oily odor is coming from the vent. | This is normal for a new oven and will disappear in time. | To speed the process, set a self-cleaning cycle for a minimum of 3 hours. See the Self clean section on page 111 . |

Troubleshooting

| Problem | Possible cause | Solution |
|--|--|---|
| Strong odor. | An odor coming from the insulation around the inside of the oven is normal for the first few times the oven is used. | Operate the oven empty on the bake setting at 400 °F for 1 hour. |
| Fan noise. | A convection fan may automatically turn on and off. | This is not a system failure but normal operation. |
| The oven racks are difficult to slide. | The shiny, silver-colored racks were cleaned in a self-cleaning cycle. | Apply a small amount of vegetable oil to a paper towel, and then wipe the edges of the oven racks with the paper towel. |
| The oven door is locked. | The circuit breaker has been tripped or there was a power failure while the oven door was locked. | Activate Control Lockout, and then unlock the control. See the Oven Control Lockout section on page 33. |

Information codes

OVEN

| Displayed code | Possible cause | Solution |
|----------------|--|---|
| C-d0 | This code occurs if the control key is short for 1 minute. | Clean the buttons and make sure there is no water on/around them. Turn off the oven and try again. If the problem continues, contact a local Dacor service center. |
| C-d1 | This code occurs if the door lock is mispositioned. | Press OFF , and then restart the oven. If the problem persists, disconnect all power to the oven for at least 30 seconds and then reconnect the power. If this does not solve the problem, call for service. |
| C-F0 | This code occurs if communication between the Main and Sub PBA is interrupted. | |
| C-F2 | This code occurs if communication between the Main and Touch is interrupted. | |
| C-10 | The cooking sensor is open when the microwave is operating. | |
| | The cooking sensor is short when the microwave is operating. | |
| C-20 | The oven sensor is open when the oven is operating. | |
| | The oven sensor is short when the oven is operating. | |
| C-21 | This code occurs if the internal temperature rises abnormally high. | |
| C-23 | The temp probe sensor is short when the oven is operating. | |
| C-30 | The PCB sensor is open when the oven is operating. | |
| | The PCB sensor is short when the oven is operating. | |
| C-31 | This code occurs if the PCB temperature rises abnormally high. | Call for service. |

Troubleshooting

| Displayed code | Possible cause | Solution |
|----------------|---|--|
| C-70 | The steam sensor is open when the oven is operating. | Press OFF , and then restart the oven. If the problem persists, disconnect all power to the oven for at least 30 seconds and then reconnect the power. If does not solve the problem, call for service. |
| | The steam sensor is short when the oven is operating. | |
| C-72 | There are drain system-related problems. | |
| C-A2 | The cooling motor is operating abnormally. | Call for service. |

Warranty and Service

Getting Help

Before you request service:
you request service:

1. Review the **Troubleshooting** section of this manual (see page 136).
2. Use the helpful tips found in our **Troubleshooting**.
3. Become familiar with the warranty terms and conditions of your product.
4. If none of these tips or suggestions resolves your problem, call our Customer Service center at the number below.

Warranty

What Is Covered

**CERTIFICATE OF WARRANTIES: DACOR OVENS
WITHIN THE FIFTY STATES OF THE U.S.A., THE DISTRICT OF COLUMBIA, AND
CANADA:**

FULL TWO-YEARS WARRANTY

The warranty applies only to the Dacor appliance sold to the first use purchaser, starting from the date of delivery to the original consumer purchaser or closing date for new construction, whichever period is longer. Warranty is valid on products purchased brand new from a Dacor Authorized Dealer, or other seller authorized by Dacor.

If your Dacor product fails to function within two years of the date of delivery to the original consumer purchaser, due to a defect in material or workmanship, Dacor will remedy it without charge to you.

All cosmetic damage (such as scratches on stainless steel, paint/porcelain blemishes, etc.) to the product or included accessories must be reported to Dacor within 60 days from the date of delivery to the original consumer purchaser to qualify for warranty coverage. Consumable parts such as filters and light bulbs are not covered and are the responsibility of the purchaser.

Warranty and Service

LIMITATIONS OF COVERAGE

Service will be provided by a Dacor designated service company during regular business hours. Please note service providers are independent entities and are not agents of Dacor. Dealer display and model home display products with a production date greater than 5 years, products sold “As Is,” and products installed for non-residential use, which include but are not limited to religious organizations, fire stations, bed and breakfast, and spas carry a two years parts warranty only. All delivery, installation, labor costs, and other service fees are the responsibility of the purchaser. Warranty will be null and void on product that has altered, defaced, or missing serial numbers and tags. The owner must provide proof of purchase or closing statement for new construction upon request. All Dacor products must be accessible for service. Warranty is null and void if non-ETL or non-CUL approved product is transported from the U.S.A.

OUTSIDE THE FIFTY STATES OF THE U.S.A, THE DISTRICT OF COLUMBIA, AND CANADA:

LIMITED TWO-YEARS WARRANTY

If your Dacor product fails to function within two years from the date of delivery to the original consumer purchaser due to a defect in material or workmanship, Dacor will furnish a new part, F.O.B. factory to replace the defective part. All delivery, installation, labor costs and other service fees are the responsibility of the purchaser.

What Is Not Covered

- Slight color variations may be noticed because of differences in painted parts, kitchen lighting, product placement, and other factors; this warranty does not apply to color variation.
- Service calls to educate the customer on proper use and care of the product.
- Service fees for travel to islands and remote areas, which include but are not limited to, ferries, toll roads or other travel expenses.
- Consequential or incidental damage, including but not limited to food or medicine loss, time away from work or restaurant meals.
- Failure of the product when used for commercial, business, rental or any application other than for residential consumer use.
- Failure of the product caused by improper product installation.
- Replacement of house fuses, fuse boxes or resetting of circuit breakers.
- Damage to the product caused by accident, fire, flood, power interruption, power surges or other acts of God.
- Liability or responsibility for damage to surrounding property including cabinetry, floors, ceilings and other structures or objects around the product.
- Breakage, discoloration, or damage to glass, metal surfaces, plastic components, trim, paint or other cosmetic finish caused by improper usage, care, abuse or neglect.

Out of Warranty

Should you experience a service issue beyond the standard warranty period, please contact us. Dacor reviews each issue and customer concern to provide the best possible solution based on the circumstances.

THE REMEDIES PROVIDED IN THE ABOVE EXPRESS WARRANTIES ARE THE SOLE AND EXCLUSIVE REMEDIES. THEREFORE, NO OTHER EXPRESS WARRANTIES ARE MADE, AND OUTSIDE THE FIFTY STATES OF THE UNITED STATES, THE DISTRICT OF COLUMBIA AND CANADA, ALL IMPLIED WARRANTIES, INCLUDING BUT NOT LIMITED TO, ANY IMPLIED WARRANTY OF MERCHANTABILITY OR FITNESS FOR A PARTICULAR USE OR PURPOSE, ARE LIMITED IN DURATION TO TWO YEARS FROM THE DATE OF DELIVERY TO THE ORIGINAL CONSUMER PURCHASER. IN NO EVENT SHALL DACOR BE LIABLE FOR INCIDENTAL EXPENSE OR CONSEQUENTIAL DAMAGES. IN THE EVENT DACOR PREVAILS IN ANY LAWSUIT, DACOR SHALL BE ENTITLED TO REIMBURSEMENT OF ALL COSTS AND EXPENSES, INCLUDING ATTORNEY'S FEES, FROM THE DACOR CUSTOMER. NO WARRANTIES, EXPRESS OR IMPLIED, ARE MADE TO ANY BUYER FOR RESALE.

Some states do not allow limitations on how long an implied warranty lasts, or do not allow the exclusion or limitation of inconsequential damages, therefore the above limitations or exclusions may not apply to you. This warranty gives you specific legal rights, and you may also have other rights that vary from state to state.

Appendix

Open source announcement

The software included in this product contains open source software. You may obtain the complete corresponding source code for a period of three years after the last shipment of this product by sending an email to <mailto:oss.request@samsung.com>.

It is also possible to obtain the complete corresponding source code in a physical medium such as a CD-ROM; a minimal charge will be required.

The following URL <http://opensource.samsung.com/opensource/SimpleConnectTP/seq/0> leads to the download page of the source code made available and open source license information as related to this product. This offer is valid to anyone in receipt of this information.



MEMO

dacor



DE68-04463A-06