

# WD53DBA900HZ

SAMSUNG

Bespoke AI Laundry Combo™ All-in-One 6.1 cu. ft. Ultra Capacity Washer with Super Speed and Ventless Heat Pump Dryer



## Signature Features

### Wi-Fi Connectivity with SmartThings

Wi-Fi connected so you can remotely start or stop your cycle, schedule laundry on your time, receive end of cycle alerts, and more right from your smartphone.<sup>1</sup>

<sup>1</sup> Samsung Smart Washer/Dryer app is available at the App Store. Please check app for compatibility with your smartphone before downloading.

### Steam Sanitize+

The Steam Sanitize+ cycle removes 99.9% of germs and bacteria, over 95% of pollen, and kills 100% of dust mites. Multi-Steam Technology steams away wrinkles, odours, and static.

### Sensor Dry

Automatically optimizes the time and temperature of your drying cycle to protect your clothes from heat damage, while avoiding excess energy use.

### SuperSpeed

Uses advanced cleaning technologies to wash a full load of laundry in just 28 minutes, without sacrificing cleaning performance.<sup>2</sup>

<sup>2</sup> Based on using SuperSpeed on a normal cycle with an 8lb load.

## Available Colour



Dark Steel

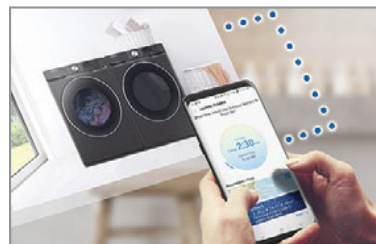

SmartThings Enabled

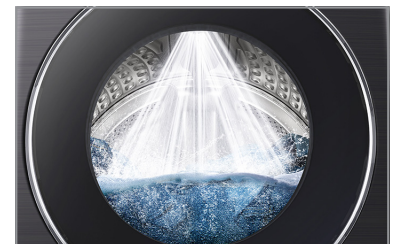

Super Speed Wash

## Features

- AI Laundry Combo™
- Ultra Capacity with Super Speed
- AI Opti Wash & Dry™
- Flex Auto Dispense System
- Easy Installation
- 7" AI Hub™ LCD Display
- Auto Open Door
- Wi-Fi Connectivity with SmartThings\*
- Steam Wash
- Voice Control
- Auto Cleaning System
- 20-Year Motor Warranty\*\*
- ENERGY STAR® Most Efficient
- AI Bubble™
- Less Microfiber Cycle
- Self Clean+ & Self Dry
- AI Energy Mode
- 1,200 RPM Maximum Spin Speed
- DIT Motor
- 23 Total Washing Cycles
- 32 Options

## Convenience

- Child Lock
- Dispenser Trays: Single Main Wash with Pebble, Bleach, Flex Auto Dispenser: Auto Detergent, Auto Softener



ENERGY STAR® rated:  
103 kWh/yr

\* Available on Android and iOS devices. A Wi-Fi connection and a Samsung account are required.

\*\* 20-year warranty limited to the Digital Inverter Motor purchased on 7/1/2022 or later. Purchase receipt indicating purchase date required for a claim. Additional restrictions and limitations apply, see warranty for details.

# WD53DBA900HZ

**SAMSUNG**

## Bespoke AI Laundry Combo™ All-in-One 6.1 cu. ft. Ultra Capacity Washer with Super Speed and Ventless Heat Pump Dryer

### Dimensions

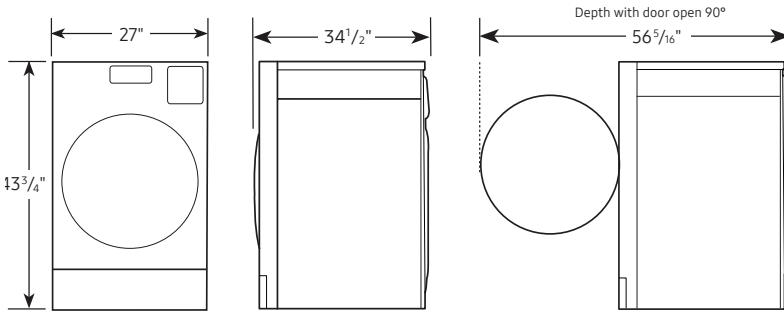

### Installation Specifications

If the Laundry Combo is installed in the same location with other washer or dryer, the front of the alcove or closet must have two unobstructed air openings for a combined minimum total area of 72-inch<sup>2</sup>.

Alcove or closet installation  
Minimum clearance for closet and alcove installations:

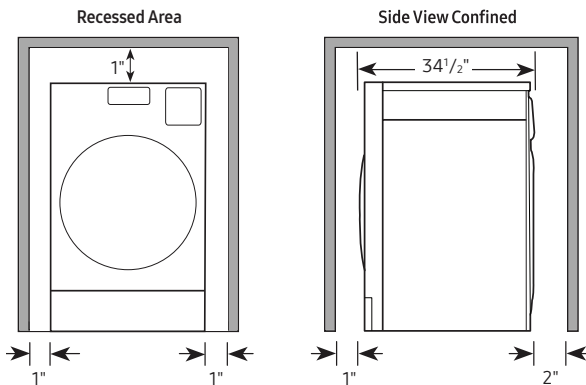

### Connection Dimensions\*

Back and side views

\*Measurements are approximations for frame only.

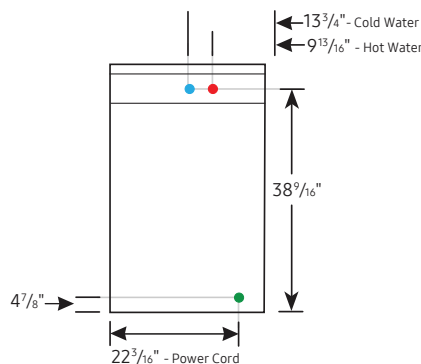
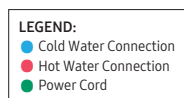

### 23 Total Cycles:

Normal, AI Opti Wash & Dry™, Super Speed, Heavy Duty, Small Load, Tide Pod Cold, Delicates, Steam Whites, Steam Sanitize, Steam Normal, Towels, Bedding, Activewear, Wool, Colors, Perm Press, Eco Cold, Rinse+Spin, Spin Only, Less Microfiber, Time Dry, Air Fluff, Product Care

### 32 Options:

Delay End, Dispenser 1 – General Detergent, Dispenser 2 - Specialty Detergent & Softener, Extra Rinse, Bubble Soak, Dry Prep, Wrinkle Prevent, Samsung Accounts, Connections, Child Lock, Sounds, Home Device Notifications, Display, Display and Style, Bixby, Microphone, Language, Liquid Units, Date and Time, Accessibility, Software Update, Support, Factory Reset, About Product, Drum Light, Auto Dispenser, Pump Clean, Auto Open Door, AI Pattern, My Cycles, Calibration, Self Diagnosis

### 5 Temperature Levels:

Extra Hot, Hot, Warm, Cold, Tap Cold

### 5 Spin Levels:

Extra High, High, Medium, Low, Extra Low

### 5 Soil Levels:

Extra Heavy, Heavy, Normal, Light, Extra Light

### 4 Dry Levels:

More Dry, Normal Dry, Less Dry, Damp Dry

### Warranty

One (1) Year Parts and Labour  
Twenty (20) Years; Washing DIT (Digital Inverter Motor) Motor Part (Part Only)

### Product Dimensions & Weight (WxHxD)

Dimensions: 27" x 43 3/4" x 34 1/2"  
Net Weight: 317.5 lb (144 kg)

### Shipping Dimensions & Weight (WxHxD)

Dimensions: 29 3/8" x 49 1/4" x 36 1/1"  
Shipping Weight: 328.5 lb (149 kg)

<b>Washer</b>	<b>Model #</b>	<b>UPC</b>
Dark Steel	WD53DBA900HZ	887276824949

Ratings	Electrical Requirements
CEE Tier 2	120 V / 60 Hz
IMEF = 2.92	
IWF = 2.9	15 Amps
103 kWh/yr	