

Owner's Manual & Assembly Guide



Model No.

EG66AN EG66BG

EG66CG EG66AB

6' x 6'

Nominal Size

! caution
sharp edges *

Gloves must be worn at all times to reduce risk of injury!

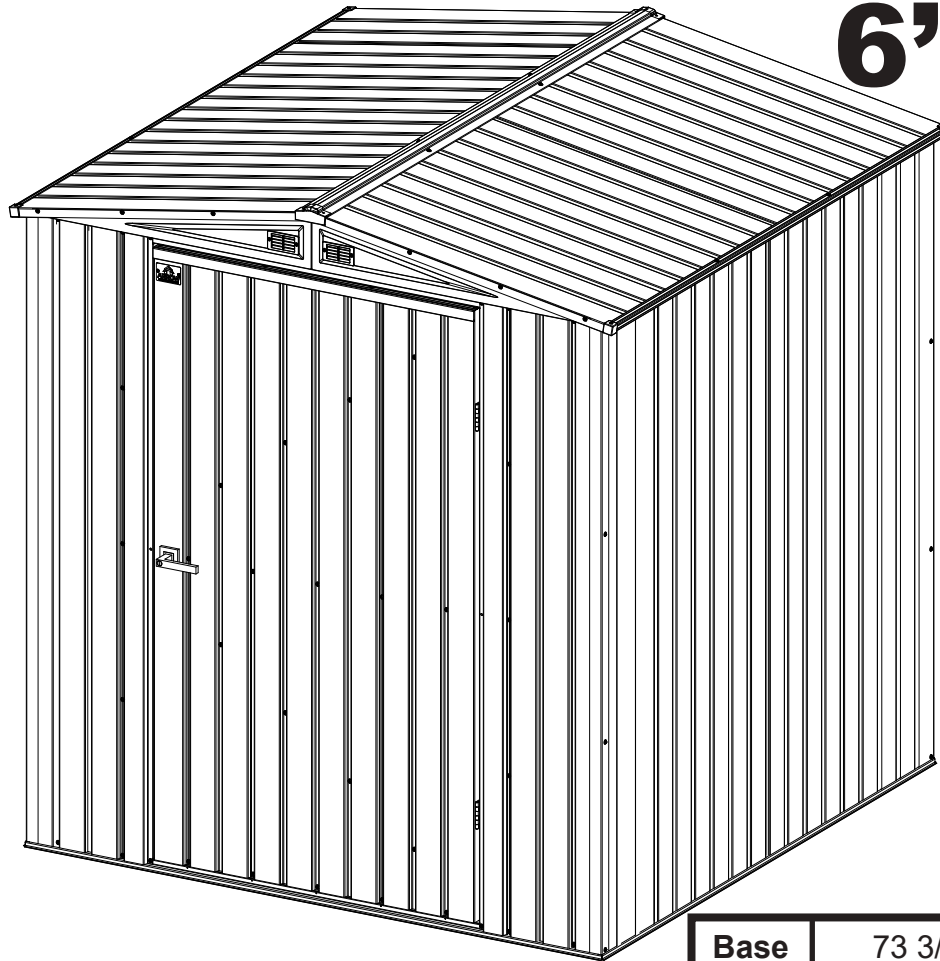

Base Size	73 3/16" x 73 3/16" 185,8 cm x 185,8 cm
------------------	--

BUILDING DIMENSIONS

†Size rounded off to the nearest foot

For proper base construction see page 11

Approx.† Size	Storage Area	Exterior Dimensions (Roof Edge to Roof Edge)			Interior Dimensions (Wall to Wall)			Door Opening	
		Width	Depth	Height	Width	Depth	Height	Width	Height
6' x 6'	34 Sq. Ft. 216 Cu. Ft.	74 15/16"	72 11/16"	79 5/8"	70 3/8"	70 3/8"	76 9/16"	39 3/8"	69 3/4"
1,8 m x 1,8 m	3,2 m ² 6,1 m ³	190,2 cm	184,7 cm	202,2 cm	178,7 cm	178,7 cm	194,5 cm	100,1 cm	177,2 cm

* See Inside for Detailed Safety Information.

Manuel de l'utilisateur et guide d'assemblage



Taille de la base 73 3/16" x 73 3/16"
185,8 cm x 185,8 cm

DIMENSIONS DU COFFRE

Taille † approx.	Zone d'entreposage	Dimensions extérieures (de bordure de toit à bordure de toit)			Dimensions intérieures (de paroi à paroi)			Ouverture de porte	
		Largeur	Profondeur	Hauteur	Largeur	Profondeur	Hauteur	Largeur	Hauteur
6' x 6'	34 Sq. Ft. 216 Cu. Ft.	74 15/16"	72 11/16"	79 5/8"	70 3/8"	70 3/8"	76 9/16"	39 3/8"	69 3/4"
1,8 m x 1,8 m	3,2 m ² 6,1 m ³	190,2 cm	184,7 cm	202,2 cm	178,7 cm	178,7 cm	194,5 cm	100,1 cm	177,2 cm

† Dimension arrondie au pied le plus proche

* Voir les informations de sécurité détaillées à l'intérieur.

Manual del propietario e instrucciones de ensamblaje



Tamaño básico 73 3/16" x 73 3/16"
185,8 cm x 185,8 cm

DIMENSIONES DE LA UNIDAD

Tamaño † aproximado	Área de almacenaje	Dimensiones exteriores (borde a borde del techo)			Dimensiones interiores (pared a pared)			Abertura de la puerta	
		Ancho	Profundidad	Altura	Ancho	Profundidad	Altura	Ancho	Altura
6' x 6'	34 Sq. Ft. 216 Cu. Ft.	74 15/16"	72 11/16"	79 5/8"	70 3/8"	70 3/8"	76 9/16"	39 3/8"	69 3/4"
1,8 m x 1,8 m	3,2 m ² 6,1 m ³	190,2 cm	184,7 cm	202,2 cm	178,7 cm	178,7 cm	194,5 cm	100,1 cm	177,2 cm

† Las medidas están redondeadas en pies

* Consulte en el interior para obtener la seguridad de información detallada.

Pflege- & Montageanleitung



Bodenabmessungen 73 3/16" x 73 3/16"
185,8 cm x 185,8 cm

ABMESSUNGEN

Ungefähre † Größe	Lagerfläche	Außenabmessungen (Dachkante zu Dachkante)			Innenabmessungen (Wand zu Wand)			Türöffnung	
		Breite	Tiefe	Höhe	Breite	Tiefe	Höhe	Breite	Höhe
6' x 6'	34 Sq. Ft. 216 Cu. Ft.	74 15/16"	72 11/16"	79 5/8"	70 3/8"	70 3/8"	76 9/16"	39 3/8"	69 3/4"
1,8 m x 1,8 m	3,2 m ² 6,1 m ³	190,2 cm	184,7 cm	202,2 cm	178,7 cm	178,7 cm	194,5 cm	100,1 cm	177,2 cm

† Angaben auf ganze Fuß gerundet

* Detaillierte Sicherheitsinformationen im Inneren.

CAUTION / ATTENTION / PRECAUCIONES/ VORSICHT

EN,FR,SP,GE-04HN

- Care must be taken when handling various pieces of your building since many contain sharp edges.
- Faire preuve de précaution pour manipuler les différentes pièces de l'abri car elles présentent de nombreux bords coupants.
- Tenga cuidado al manipular las diferentes piezas de la estructura ya que pueden tener bordes filosos.
- Verschiedene Teile Ihres Schuppens müssen vorsichtig gehandhabt werden, denn viele haben scharfe Kanten.

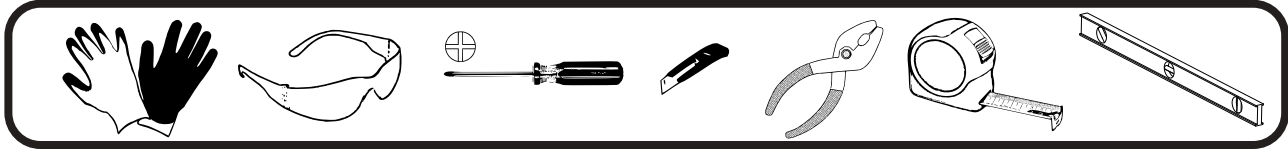

- Do NOT attempt to assemble your building before double checking that you have all the parts indicated in the parts lists. Any building left partially assembled may be seriously damaged by even light winds.
- Ne PAS tenter d'assembler l'abri avant d'avoir vérifié la présence de toutes les pièces figurant dans la liste des pièces. Tout abri laissé partiellement assemblé peut être gravement endommagé par des vents même légers.
- NO trate de montar la estructura antes de verificar que tenga todas las piezas indicadas en la lista de piezas. Cualquier estructura sin terminar puede ser dañada seriamente incluso por vientos ligeros.
- Versuchen Sie NICHT, Ihren Schuppen an einem windigen Tag aufzustellen. Die großen, flächigen Bauteile könnten wie ein Segel vom Wind erfasst und herumgeschleudert werden, was die Aufstellarbeiten erschwert und gefährlich macht.
- Do NOT attempt to assemble your building on a windy day. The large panels can catch the wind like a "sail", making construction difficult and unsafe. **Watch the Weather Closely**
- Ne PAS tenter d'assembler l'abri en présence de vent. Les grands panneaux peuvent se comporter comme une voile et « battre » au vent, rendant la construction difficile et dangereuse. **Suivre la météo avec attention**
- NO trate de montar la estructura en un día ventoso. Los paneles grandes pueden atrapar el viento como una "vela", lo que hace que sean llevados por el viento, lo que, a su vez, hace que la construcción sea difícil e insegura. **Observe el clima atentamente**
- Versuchen Sie NICHT, Ihren Schuppen zu montieren, bevor Sie sich nochmals vergewissert haben, dass Sie alle in der Teilleiste. Ein nur teilweise montiert zurückgelassener Schuppen kann bereits durch leichten Wind schwer beschädigt werden.
- Keep children and pets away from the worksite during construction and until the building is completely assembled. This will help avoid distractions and any accidents which may occur.
- Tenir les enfants et les animaux domestiques à l'écart du chantier durant la construction et jusqu'à ce que l'abri soit complètement assemblé. Cela évite les distractions et les accidents potentiels.
- No permita entrar a niños ni animales domésticos en el lugar de trabajo durante la construcción y hasta que la estructura esté completamente montada. Esto ayudará a evitar distracciones y cualquier accidente que pueda producirse.
- Halten Sie Kinder und Haustiere während der Montage und bis der Schuppen vollständig aufgestellt ist vom Aufstellplatz fern. Dies hilft, Ablenkungen und damit einhergehende Unfälle zu verhindern.
- NEVER concentrate your weight on the roof of the building.
- NE JAMAIS concentrer son propre poids sur le toit de l'abri.
- NUNCA concentre su peso en el techo de la estructura.
- Belasten Sie das Dach des Schuppens NIEMALS punktuell mit Ihrem Gewicht.
- Before assembling any parts, your base should be constructed and an anchoring system should be ready to use. Your building MUST be anchored to prevent wind damage.
- Avant de commencer à assembler des pièces, la base doit avoir été construite et le système d'ancrage doit être prêt à l'emploi. L'abri doit IMPÉRATIVEMENT être ancré pour éviter les dommages par le vent.
- Antes de montar cualquier pieza, debe estar construida la base y preparado el sistema de anclaje. La estructura DEBE estar anclada para evitar daños por vientos.
- Das Fundament sollte vor dem Zusammenbau der Teile gebaut und das Verankerungssystem nutzungsbereit sein. Ihr Schuppen MUSS verankert werden, um Schäden durch Wind zu verhindern.

- The best location is a level area with good drainage.
- Le meilleur emplacement sera une surface de niveau à bon drainage.
- El mejor lugar es un área nivelada con buen drenaje.
- Der bestmögliche Bauplatz ist eben mit einer guten Drainage.
- Allow enough space outside the building to be able to access the roof with a ladder.
- Laissez suffisamment d'espace à l'extérieur du bâtiment pour être en mesure d'accéder à la toiture avec une échelle.
- Deje suficiente espacio afuera del edificio para poder tener acceso al techo con una escalera.
- Es muß außerdem genügend Platz außerhalb des Gerätehauses vorgesehen werden, damit die Blechschrauben von außen aus verschraubt werden können.
- **Use Teamwork:** Two or more people are required to assemble your building.
- **Travailler en équipe:** Deux personnes ou plus sont nécessaires pour assembler l'abri.
- **Trabaje en equipo:** Se necesitan dos o más personas para ensamblar su cobertizo.
- **Arbeiten Sie im Team:** Mindestens zwei Personen werden für die Montage des Gerätehauses benötigt.

**CARE & MAINTENANCE / SOINS ET ENTRETIEN / PROTECCIÓN Y CONSERVACIÓN/
PFLEGE & INSTANDHALTUNG**

- DO NOT use power washing to clean your shed.
- NE PAS utiliser de jet sous haute pression pour nettoyer l'abri.
- NO utilice hidrolavadora para limpiar el cobertizo.
- Reinigen Sie Ihren Schuppen NICHT mit dem Hochdruckreiniger.
- Combustibles and corrosives must be stored in air tight containers designed for chemical and/or combustible storage. Corrosive chemicals such as fertilizers, pesticides and herbicides should be cleaned off the interior and exterior surfaces immediately. Rust caused by chemical damage is not covered by the warranty.
- Les matières combustibles et corrosives doivent être entreposées dans des contenants étanches à l'air conçus pour l'entreposage de produits chimique et/ou combustibles. Les produits chimiques corrosifs tels que les engrais, pesticides et herbicides doivent immédiatement être nettoyés des surfaces intérieures et extérieures. La rouille causée par des produits chimiques n'est pas couverte par la garantie.
- Los combustibles y productos corrosivos deben guardarse en contenedores herméticos diseñados para almacenamiento de químicos o combustibles. Se deben limpiar inmediatamente los químicos corrosivos, como fertilizantes, pesticidas y herbicidas, de las superficies interiores y exteriores. El óxido causado por daños químicos no está cubierto por la garantía.
- Brennbare und ätzende Stoffe müssen in luftdichten Behältern gelagert werden, die zur Lagerung von Chemikalien und/oder Brennstoffen vorgesehen sind. Ätzende Chemikalien wie z. B. Dünger, Insektenvernichter und Unkrautvernichter sollten sofort von den Innen- und Außenflächen abgewischt werden. Durch die Lagerung von Chemikalien entstandener Rost wird nicht von der Gewährleistung abgedeckt.

**Rust protection precautions / Des mesures de protection contre la rouille /
Las precauciones de protección contra el óxido/ Rostschutzmaßnahmen**









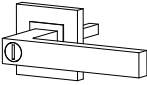

- Avoid nicking or scraping the coating surface, inside and out.
- Éviter d'entailler ou de rayer le revêtement de surface, à l'intérieur comme à l'extérieur.
- Evite dañar o raspar la capa protectora, por dentro y por fuera.
- Vermeiden Sie es, die Oberflächenbeschichtung an der Innen- und Außenseite zu beschädigen oder zu verkratzen.
- Keep roof, base perimeter and door free of debris.
- Nettoyer le toit, le pourtour de la base et les rails de porte de tous débris.
- Mantenga el techo, el perímetro de la base y los rieles de la puerta sin desechos.
- Halten Sie das Dach, den Bodenbereich und die Türführungen stets frei von Verunreinigungen.
- Touch up scrapes or nicks and any area of visible rust as soon as possible.
- Retoucher les entailles et égratignures et toute surface de rouille visible dès que possible.
- Retoque las raspaduras o las muescas y cualquier área de todo óxido visible lo más pronto posible.
- Bessern Sie Kratzer oder Beschädigungen und alle Bereiche mit sichtbarem Rost so schnell wie möglich aus.

HARDWARE LIST

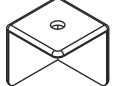
LISTE DE LA VISSERIE
LISTA DE PIEZAS

KLEINTEILELISTE

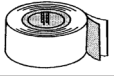
06HBa

Key No. Rep. N.º de referencia Lfd. Nr.	Part No. Réf. pièce N.º de pieza Art.-Nr.	Part Description	Description de la pièce	Descripción de la pieza	Bezeichnung	Qty. Qté Cant. Menge	Part Views Profils de pièces Vistas desde un extremo Vor-handen
1	65103	Hex Nut (#8-32) / Écrou hexagonal (8-32) / Tuerca hexagonal (N.º 8-32) / Sechskantmutter (#8-32)				72	
2	65923	Small Bolt (#8-32 x 3/8) (10 mm) / Petit boulon (8-32 x 3/8) (10 mm) / Perno pequeño color arena (N.º 8-32 x 3/8) (10 mm) / Kleine Maschinenschraube (#8-32 x 3/8) (10 mm)				60	
3	65004	Small Screw (#8AB x 5/16) (8 mm) / Petite vis (8AB x 5/16) (8 mm) / Tornillo pequeño color arena (N.º 8AB x 5/16) (8 mm) / Kleine Blechschraube (#8AB x 5/16) (8 mm)				225	
4	30000	Locking Handle Right / Poignée verrouillable droite / Manija de bloqueo derecha / Verriegelungsgriff rechts				1	
5	30040	Hinge / Charnière / Bisagra / Scharnier				2	
6	60H	Corner Cap / Coin bouchon / Tapa de esquina / Dachleisten-Abschlusskappe				4	
7	66646	Washer Sheet / Plaque de rondelles / Plancha de arandelas / Unterlegscheiben				6	
8	30027	Peak Cap / Embout de faîte / Tope del caballete / Firstkappe				2	
9	66847	Gable Vent / Grilles de ventilation / Rejillas de ventilación / Dachgiebelentlüfter				4	
10	30028	Nameplate / Plaque signalétique / Placa de identificación / Typenschild				1	
11	67293	Weather Stripping / Ruban de calfeutrage / Burlete / Dichtungsband				1	
12	66783	Flathead Bolt (#8-32 x 1/2) (13 mm) / Boulon à tête plate (#8-32 X 1/2) (13 mm) / Perno de cabeza chata (N.º 8-32 x 1/2) (13 mm) / Senkkopf-Maschinenschraube (#8-32 x 1/2) (13 mm)				12	

The fasteners used in each step are shown actual size at the top of each page. If you are unsure which fastener to use, hold it up to the picture and use the one that matches.

Les éléments de visserie utilisés à chaque étape sont représentés en taille réelle en haut de chaque page. En cas de doute sur le type de visserie à utiliser, les placer sur l'image et utiliser celui qui correspond.







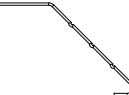
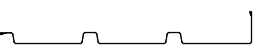
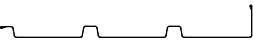
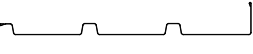
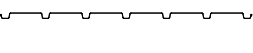

Los tornillos y pernos que se utilizan en cada paso se muestran en el tamaño real en la parte superior de cada página. Si no está seguro de qué tornillo o perno de usar, compárelo con la imagen y use el que coincida con ella.

Die in den jeweiligen Schritten verwendeten Verbindungselemente werden am oberen Seitenrand jeweils in tatsächlicher Größe gezeigt. Falls Sie unsicher sind, welches Verbindungselement Sie verwenden sollen, dann halten Sie es vor das Bild und verwenden Sie dasjenige, das passt.

PARTS LIST

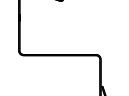
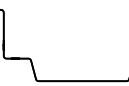
LISTE DES PIÈCES
ARTÍCULOS DE FERRETERÍA TEILELISTE

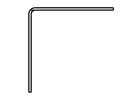







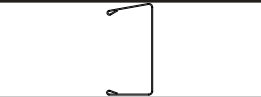
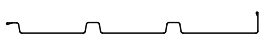
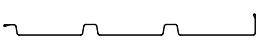
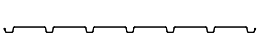

EN,FR,SP,GE-07HBa

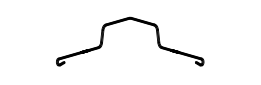
Key No. Rep. N.º de referencia Lfd. Nr.	Part No. Réf. pièce N.º de pieza Art.-Nr.	Part Description	Description de la pièce	Descripción de la pieza	Bezeichnung	Qty. Qté Cant. Menge	Part Views Profils de pièces Vistas desde un extremo Vor-handen
13	11338	Floor Frame / Cadre de plancher / Tirante del entramado del piso / Bodenrahmen				4	
14	11339	Ramp / Seuil / Rampa / Türschwelle				1	
15	11340	Rear Corner Panel / Panneau de coin arrière / Panel esquinero trasero / Eckblech hinten				2	
16	11341	Front Corner Panel / Panneau d'angle avant / Panel de la delantero esquina / Eckblech vorne				2	
17	11342	Side Corner Panel / Panneau de mur latéral / Panel esquinero lateral / Eckblech Seiten				4	
18	11343	Wall Panel / Panneau de mur / Panel de la pared / Wandblech				6	
19	11344	Wall Channel / Longeron de mur / Canaleta de la pared / Wand verstrebung				3	
20	11345	Side Wall Angle / Cornière de mur latéral / Ángulo de la pared lateral / Seitenwandwinkel				2	
21	11346	Rear Wall Angle / Cornière arrière / Ángulo de la pared trasera / Rückwandwinkel				1	
22	11347	Lintel / Linteau / Dintel / Sturz				1	
23	11348	Door Jamb Right / Jambage de porte droit / Jamba de la puerta derecha / Türpfosten rechts				1	
24	80209	Door Jamb Left / Jambage de porte gauche / Jamba de la puerta izquierda / Türpfosten links				1	
25	6658	Gable Brace / Renfort de pignon / Abrazadera del gablete / Giebelverstärkung				2	
26	11212	Right Gable / Pignon droit / Gablete derecho / Giebel rechts				2	

PARTS LIST

LISTE DES PIÈCES
ARTÍCULOS DE FERRETERÍA TEILELISTE

EN,FR,SP,GE-08HBa

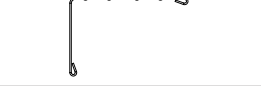
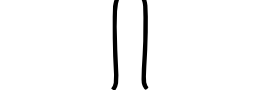
Key No. Rep. N.º de referencia Lfd. Nr.	Part No. Réf. pièce N.º de pieza Art.-Nr.	Part Description			Qty. Qté Cant. Menge	Part Views Profils de pièces Vistas desde un extremo Vor-handen
		Description	Description de la pièce	Descripción de la pieza		
27	80163	Left Gable / Pignon gauche / Gablete izquierdo / Giebel links			2	
28	11349	Roof Beam / Poutre de toit / Viga del techo / Dachträger			2	
29	11350	Right Roof Panel / Panneau de toit droit / Panel del techo derecho / Dachblech rechts			2	
30	80211	Left Roof Panel / Panneau de toit gauche / Panel del techo izquierdo / Dachblech links			2	
31	11351	Roof Panel / Panneau de toit / Panel del techo / Dachblech			4	
32	11352	Roof Trim / Garniture de toit / Contramarco del techo / Dachabschlussleiste			2	
33	11353	Ridge Cap / Faîtage / Tope del caballete / Firstabdeckung			1	
34	11354	Door Panel Hinge Side / Coté charnière du panneau de porte / Panel de puerta lateral de bisagra / Türverkleidung Bandseite			1	
35	11355	Door Panel / Panneau porte / Panel puerta / Tür			1	
36	11356	Door Edge / Bord de porte / Borde de la puerta / Türkante			1	
37	11357	Vertical Door Channel / Canal d'ouverture verticale de la porte / Canal de puerta vertical / Vertikale Türschiene			2	
38	11358	Horizontal Door Channel / Canal d'ouverture horizontale de la porte / Canal de puerta horizontal / Horizontale Türschiene			2	
39	11359	Diagonal Door Brace / Renfort diagonal de porte / Abrazadera diagonal de la puerta / Diagonale Türversteifung			2	
40	11360	Door Handle Brace / Renfort de poignée de porte / Abrazadera de la manija de la puerta gablete / Türgriffversteifung			1	
41	11361	Door Trim / Garniture de porte / Moldura de la puerta / Türverkleidung			1	
42	69836	Edge Trim / Garniture de bordure / Contramarco del gablete de / Kantenschutz			4	

ASSEMBLY BY KEY NO.

PIÈCES PAR N° DE REPÈRE MONTAGE NACH LFD. NR. 99HBa
MONTAJE POR N.º DE REFERENCIA

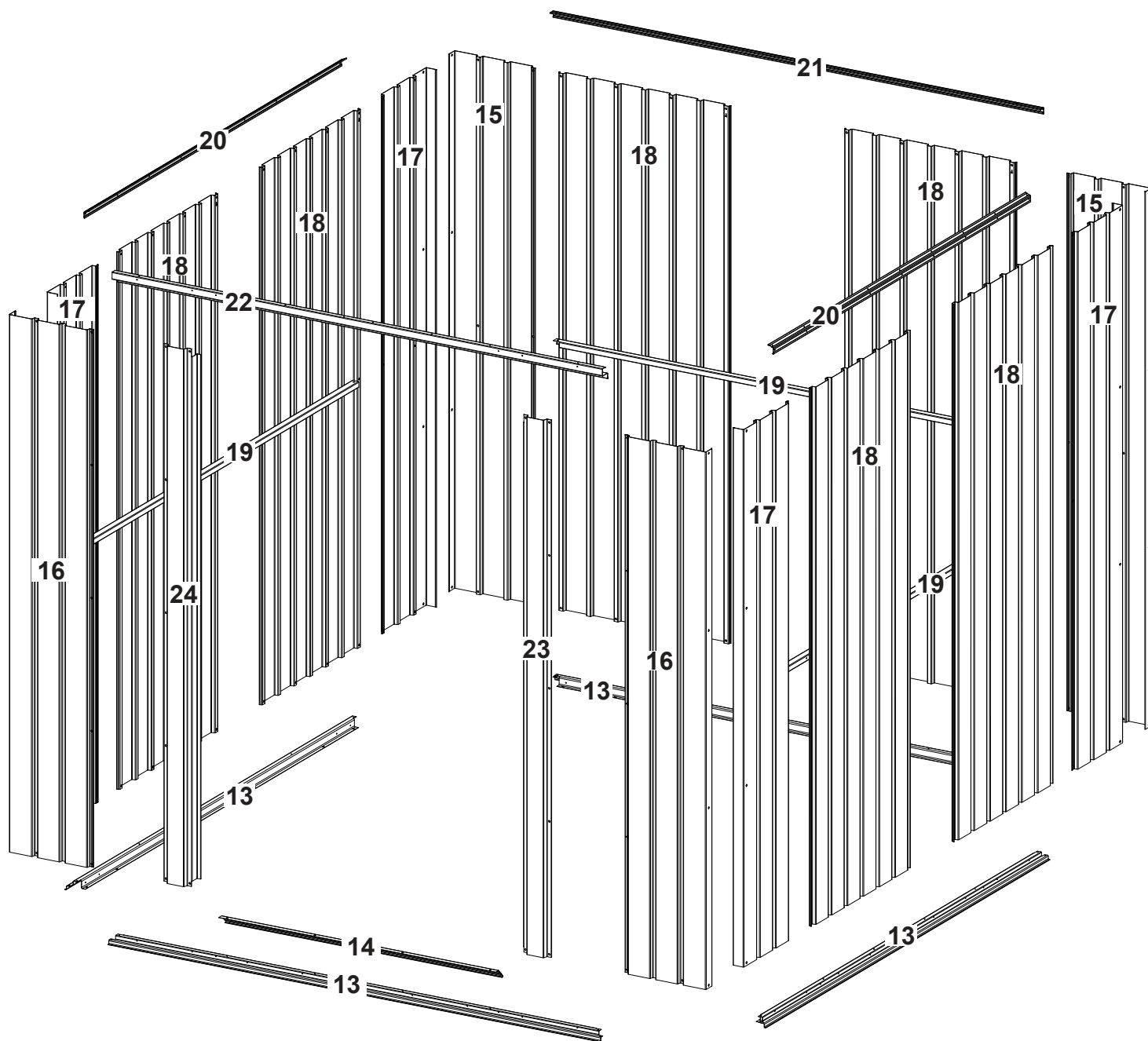

ASSEMBLY BY KEY NO.

PIÈCES PAR N° DE REPÈRE MONTAGE NACH LFD. NR. 10HBa
MONTAJE POR N.º DE REFERENCIA

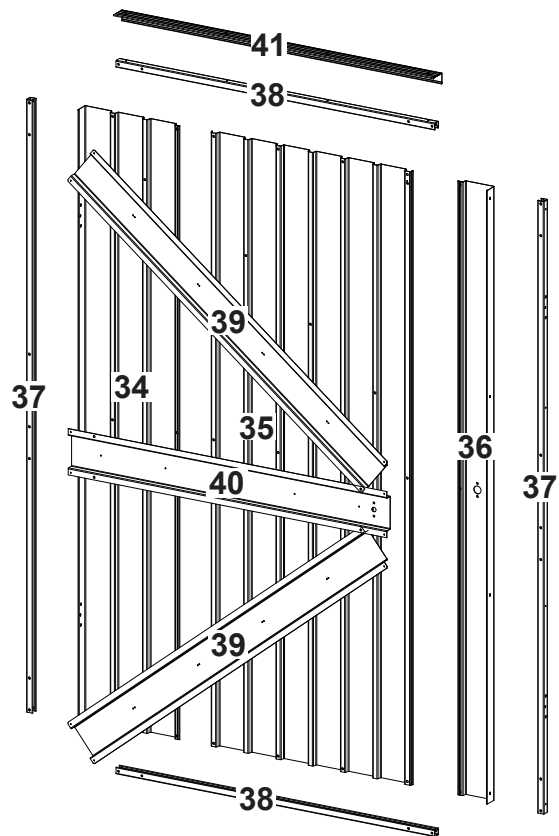
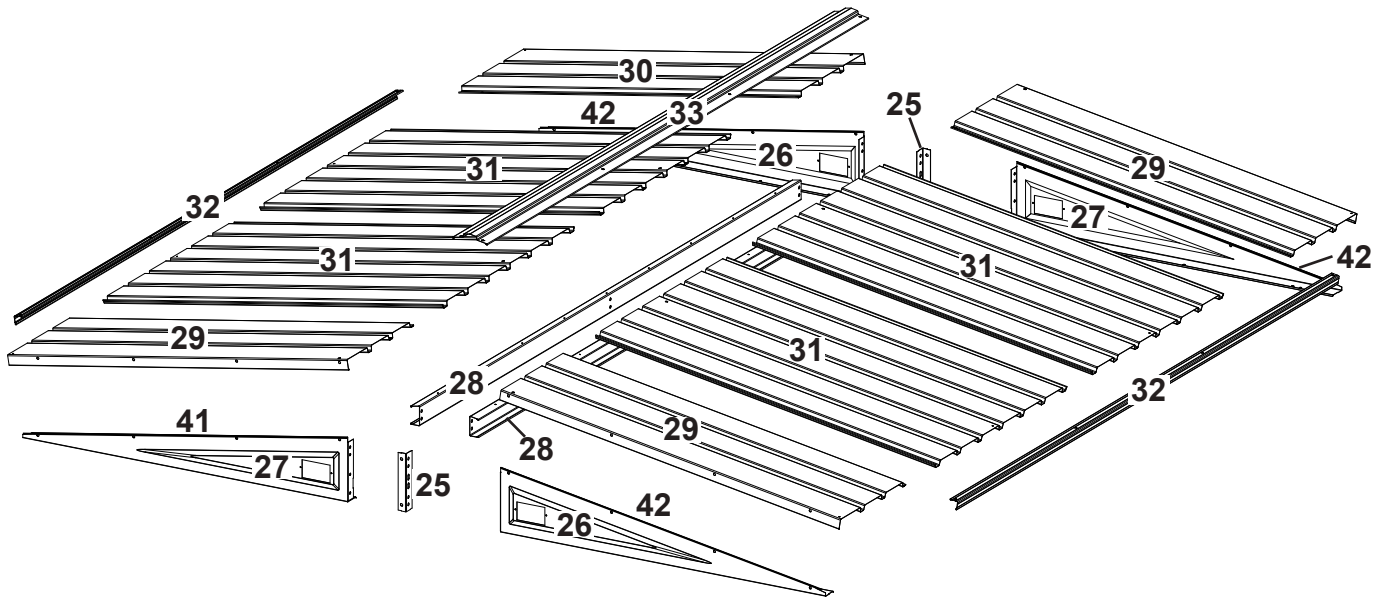

Wood Platform / Plateforme en bois

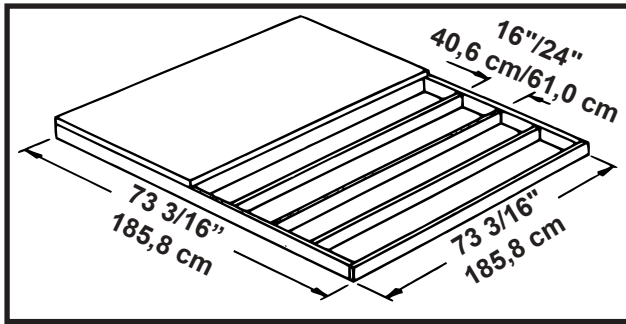

Concrete Slab / Dalle en béton

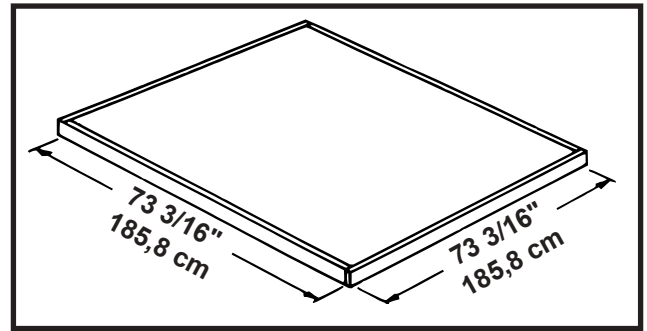

* IMPORTANT *

The base **MUST** be flat and level to provide adequate support for your building, otherwise the **PRE-DRILLED HOLES WILL NOT ALIGN AND IT CANNOT BE ASSEMBLED**. No matter which of the options below you choose for a base, an **ARROW ANCHORING KIT** is recommended as an effective method of properly securing your building after assembly is complete.

OPTION 1: Build directly on the ground

OPTION 2: Wood Platform

NOTE: Pressure Treated Lumber must **NOT** be used where it will make contact with your storage building. The properties of Pressure Treated Lumber will cause accelerated corrosion. **If Pressure Treated Lumber comes in contact with your storage building your warranty will be voided.** The platform should be level and flat (free of bumps, ridges, etc.) to provide good support for the building. The necessary materials may be obtained from your local lumber yard.

OPTION 3: Concrete Slab

The slab should be at least **4" (10,2 cm)** thick.

* IMPORTANT *

La base **DOIT** être plate et de niveau pour fournir un support adéquat à votre bâtiment, sinon les trous **PRÉ-PERCÉS NE S'ALIGNERONT PAS ET ILS NE POURRONT PAS ÊTRE ASSEMBLÉS**. Quelque que soit l'option ci-dessous choisie pour la base, un **NÉCESSAIRE D'ANCRAGE ARROW** est recommandé pour amarrer solidement l'abri une fois que le montage est terminé.

OPTION 1 : Construire à même le sol

OPTION 2 : Plateforme en bois

REMARQUE : Ne **PAS** utiliser de bois traité sous pression aux points de contact avec l'abri. **Le bois traité sous pression contribue à accélérer la corrosion. Le contact de bois traité sous pression avec l'abri aura pour effet d'annuler la garantie.** La plateforme doit être plate et de niveau (sans bosses, arêtes, etc.) afin d'offrir un bon support à l'abri. Les matériaux nécessaires peuvent s'obtenir auprès d'un fournisseur de bois d'œuvre local.

OPTION 3 : Dalle en béton

La dalle doit avoir au moins **4 "(10,2 cm)** d'épaisseur.

Plataforma de Madera / Plattform aus Holz

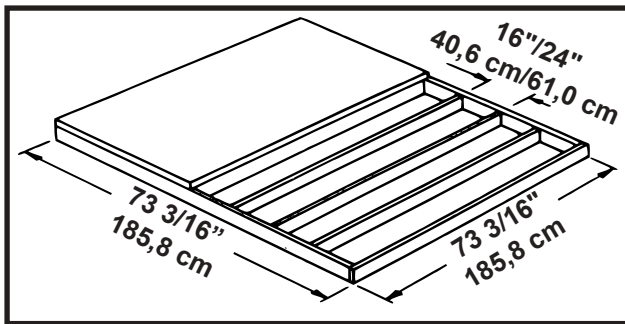

Losa de Hormigón / Bodenplatte aus Beton

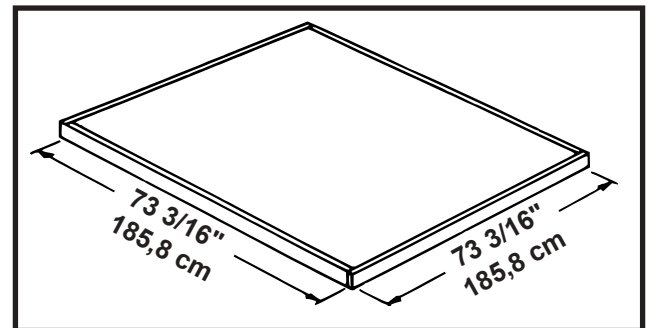

* IMPORTANTE *

La base **DEBE** ser plana y nivelada para proporcionar el soporte adecuado para su edificio; de lo contrario, los **AGUJEROS PRETALADRADOS NO SE ALINEARÁN Y NO SE PUEDEN MONTAR**. Independientemente de las siguientes opciones que elija como base, se recomienda un KIT DE SUJECIÓN ARROW como método eficaz para sujetar adecuadamente su cobertizo después de terminar el ensamblaje.

OPCIÓN 1: Construir directamente en el suelo

OPCIÓN 2: Plataforma de madera

NOTA: La madera tratada a presión **NO** debe usarse donde haga contacto con su edificio de almacenamiento. Las propiedades de la madera tratada a presión causarán corrosión acelerada. **Si la madera tratada a presión entra en contacto con su edificio de almacenamiento, su garantía quedará anulada.** La plataforma debe estar nivelada y plana (libre de golpes, crestas, etc.) para proporcionar un buen soporte para el edificio. Los materiales necesarios se pueden obtener de su aserradero local.

OPCIÓN 3: Losa de hormigón

La losa debe tener **al menos 4" (10,2 cm)** de espesor.

WICHTIG

Der Sockel **MUSS** flach und eben sein, um eine angemessene Unterstützung für Ihr Gebäude zu gewährleisten. Andernfalls werden die **VORGEBOHRTEN LÖCHER NICHT AUSGERICHTET UND ES KANN NICHT ZUSAMMENGEBAUT WERDEN**. Unabhängig davon, für welche der nachfolgend genannten Möglichkeiten Sie sich als Fundament entscheiden, empfiehlt sich ein **ARROW-VERANKERUNGSKIT** als wirkungsvolle Methode zur ordnungsgemäßen Sicherung Ihres Bauwerks nach Abschluss der Montagearbeiten.

MÖGLICHKEIT 1: Direkt auf dem Untergrund (Erde)

MÖGLICHKEIT 2: Plattform aus Holz

HINWEIS: An Stellen, an denen es mit Ihrem Geräteschuppen in Kontakt kommen würde, darf **kein** kesseldruckimprägniertes Holz verwendet werden. Kesseldruckimprägniertes Holz hat Eigenschaften, die zu beschleunigter Korrosion führen. **Wenn kesseldruckimprägniertes Holz mit Ihrem Geräteschuppen in Kontakt kommt, wird Ihre Garantie ungültig.**

MÖGLICHKEIT 3: Bodenplatte aus Beton

Die Bodenplatte sollte **wenigstens 10,2 cm** stark sein.

1: FLOOR FRAME

CADRE DE PLANCHER
MARCO DE PISO
BODENRAHMEN

13HB

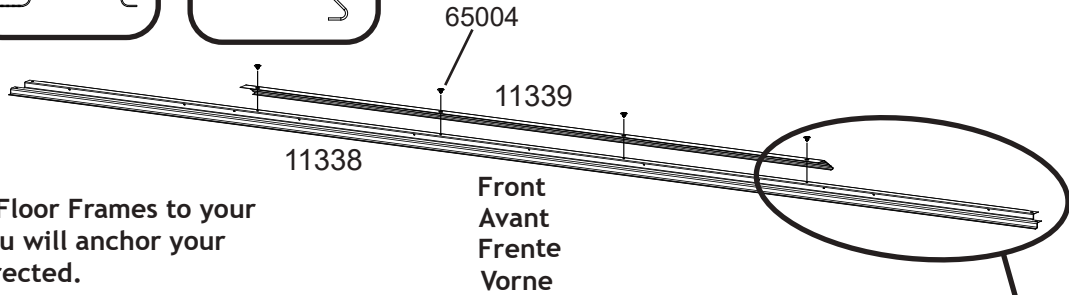
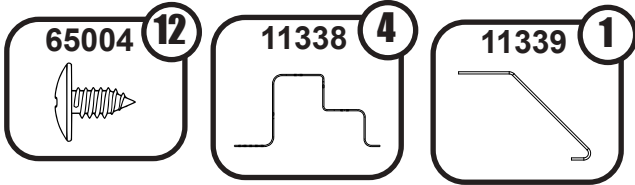

NOTES:

Do NOT fasten your Floor Frames to your Base at this time. You will anchor your building after it is erected.

The Floor Frame must be BOTH square AND level or the holes will not line up properly.

Measure diagonally from corner to corner. When diagonal measurements are equal, the Frame is square.

REMARQUES:

Ne PAS attacher les éléments de cadre de plancher à la base à ce stade. L'abri sera ancré une fois qu'il est assemblé.

Le cadre de plancher doit être À LA FOIS d'équerre et de niveau pour que les trous s'alignent correctement.

Mesurer en diagonale d'un coin à l'autre. Lorsqu'elles sont égales, le cadre de plancher est d'équerre.

NOTAS:

NO fije los tirantes del piso a la base en este momento. Anclará la estructura después de que esté erguida.

El tirante del piso debe estar TANTO cuadrado COMO nivelado o los orificios no se alinearán correctamente.

Mida diagonalmente de esquina a esquina. Cuando las medidas diagonales son iguales, el tirante está cuadrado.

HINWEIS:

Befestigen Sie Ihre Bodenrahmen noch NICHT am Fundament. Sie verankern Ihr Bauwerk erst, nachdem es fertig aufgebaut ist.

Der Bodenrahmen muss SOWOHL rechtwinklig ALS AUCH waagrecht sein. Andernfalls fluchten die Löcher nicht richtig.

Messen Sie diagonal von Ecke zu Ecke. Wenn die diagonalen Abmessungen gleich sind, ist der Rahmen rechtwinklig.

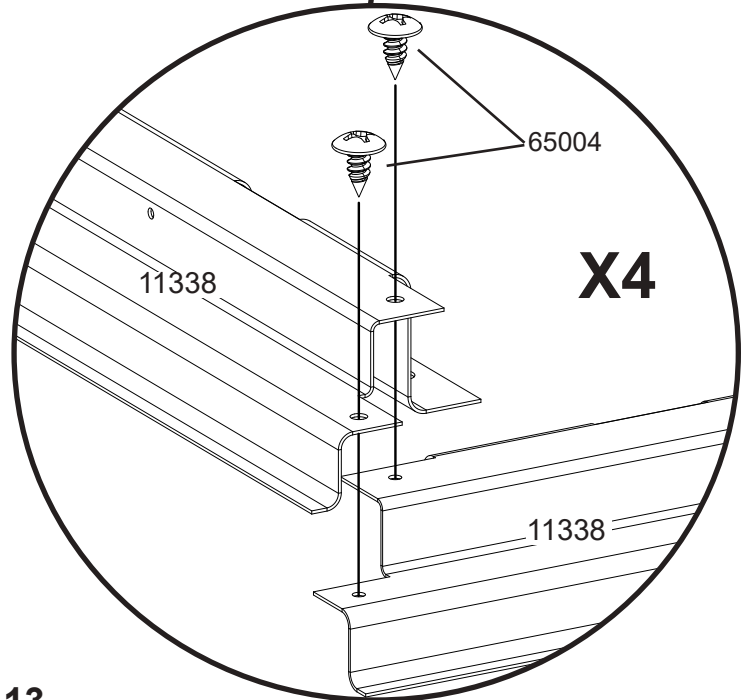
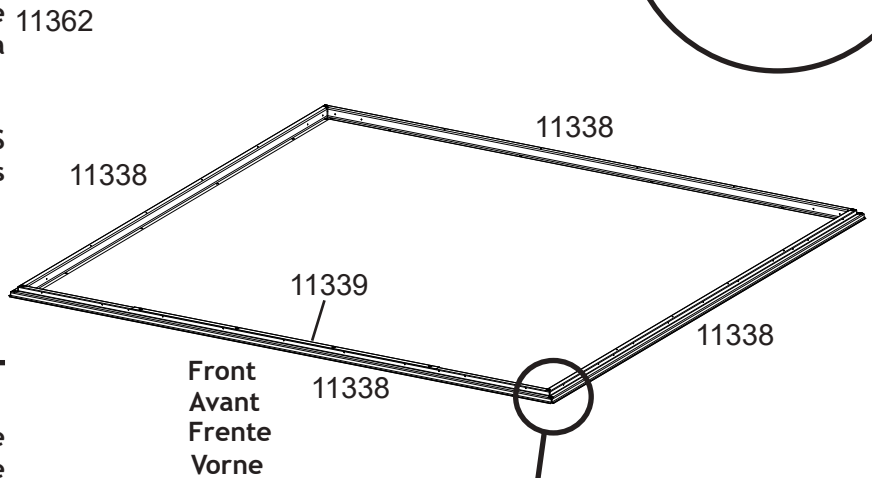

2: CORNER PANELS

PANNEAUX D'ANGLE
PANELES DE ESQUINA ECKPLATTEN

14HB

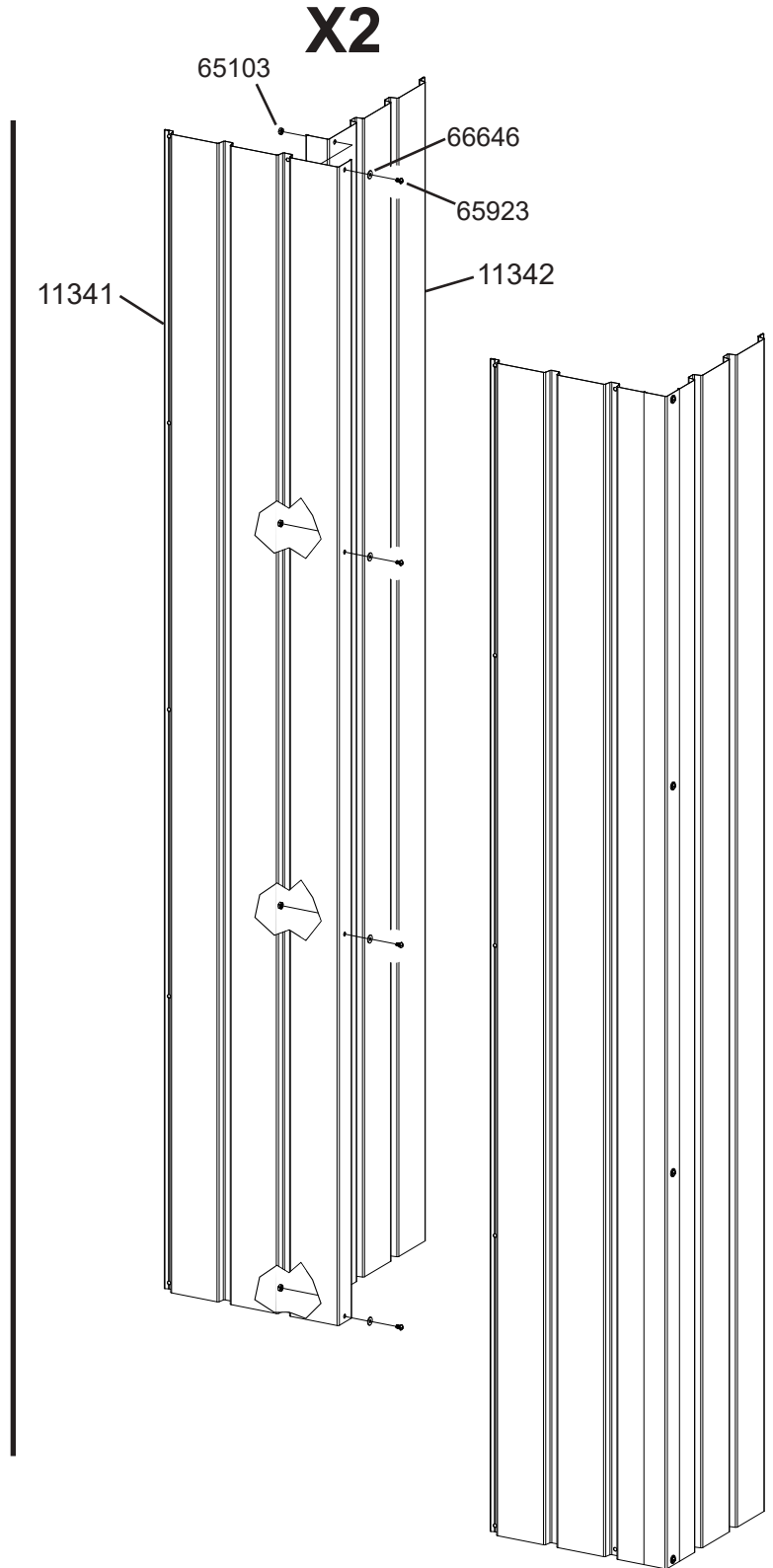
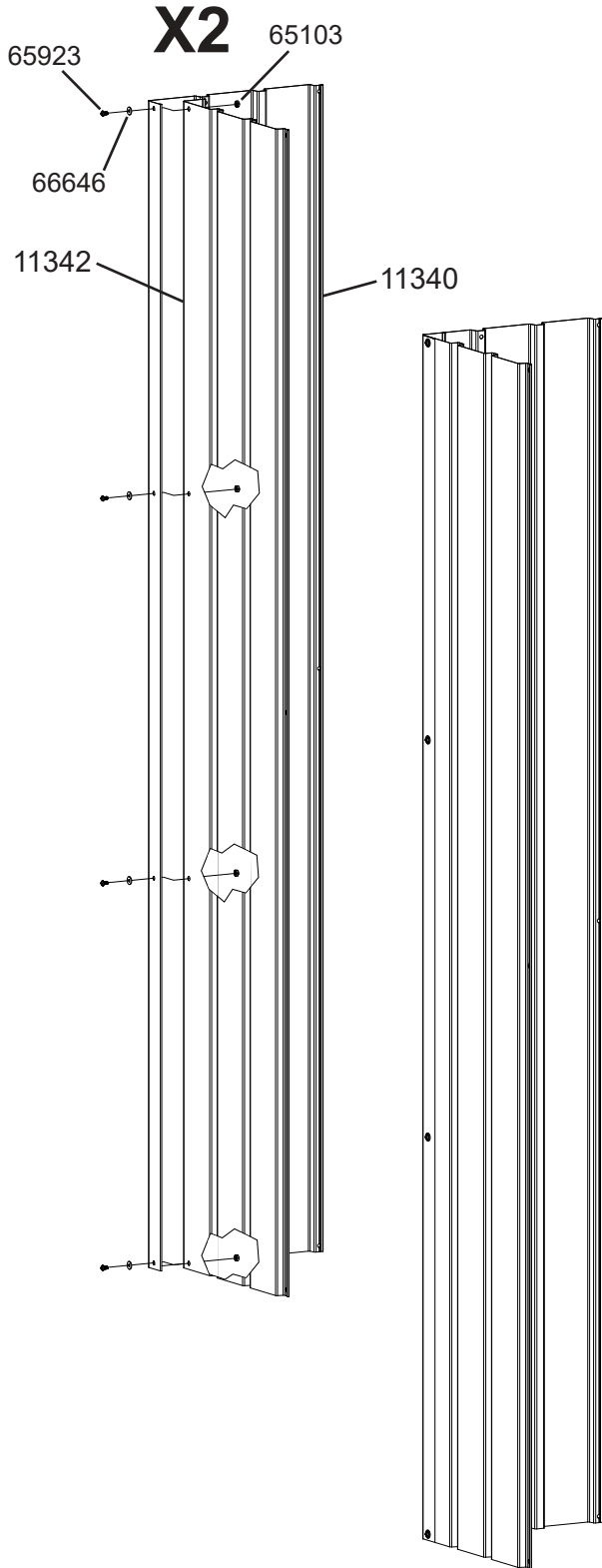
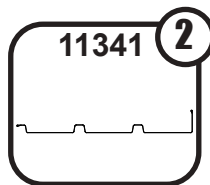
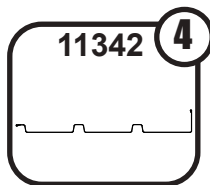
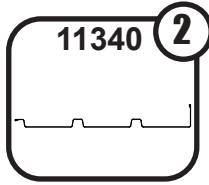
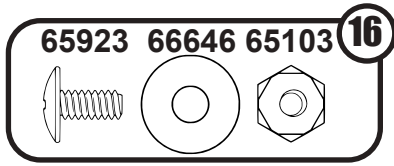

2: CORNER PANELS

PANNEAUX D'ANGLE
PANELES DE ESQUINA ECKPLATTEN

15HB

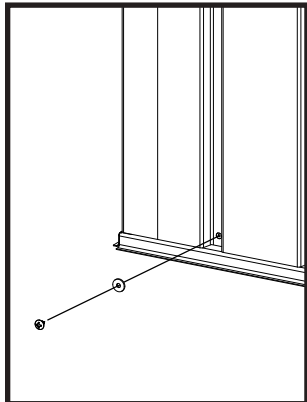
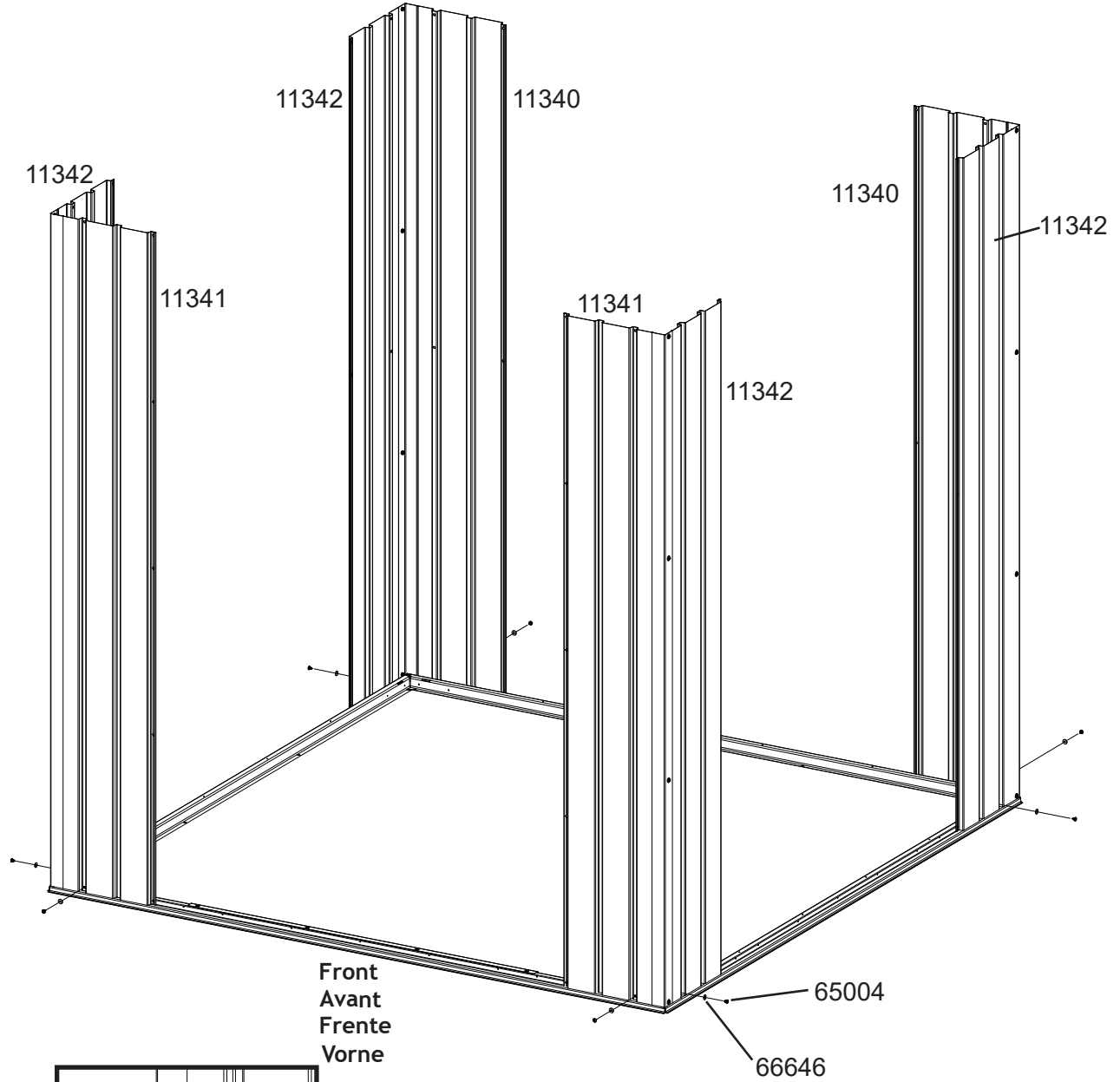
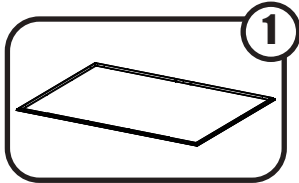
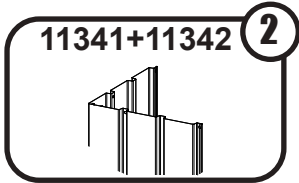
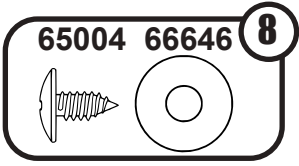

3: WALL ANGLE

CORNIÈRE DE MUR
ÁNGULO DE LA PARED
WANDWINKEL

16HB

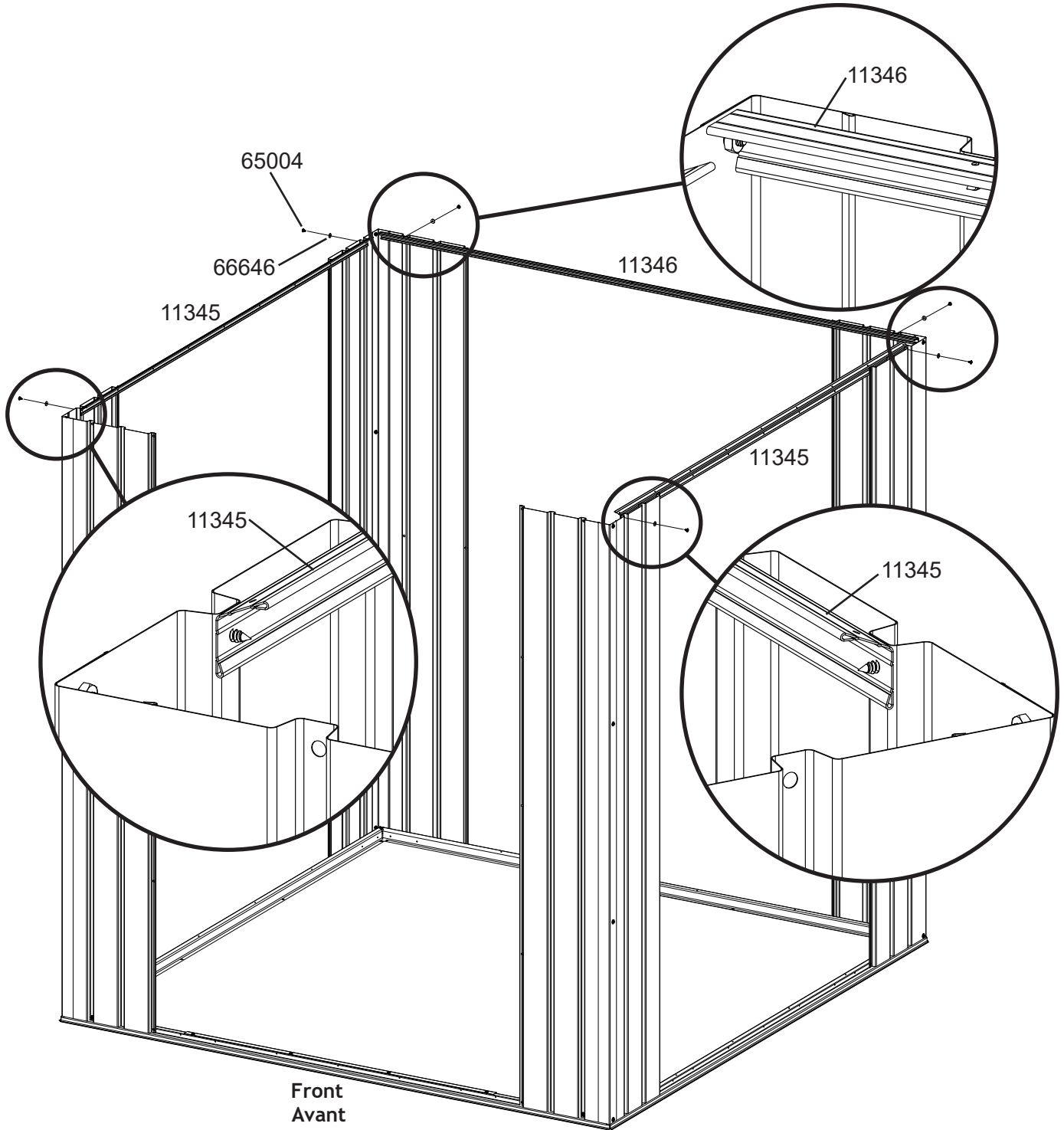
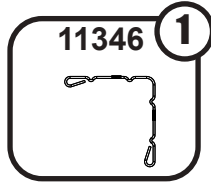
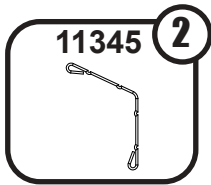
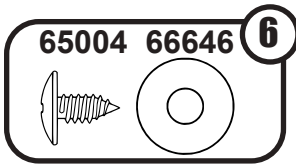

Front
Avant
Frente
Vorne

4: LINTEL

LINTEAU
DINTEL STURZ

17HB

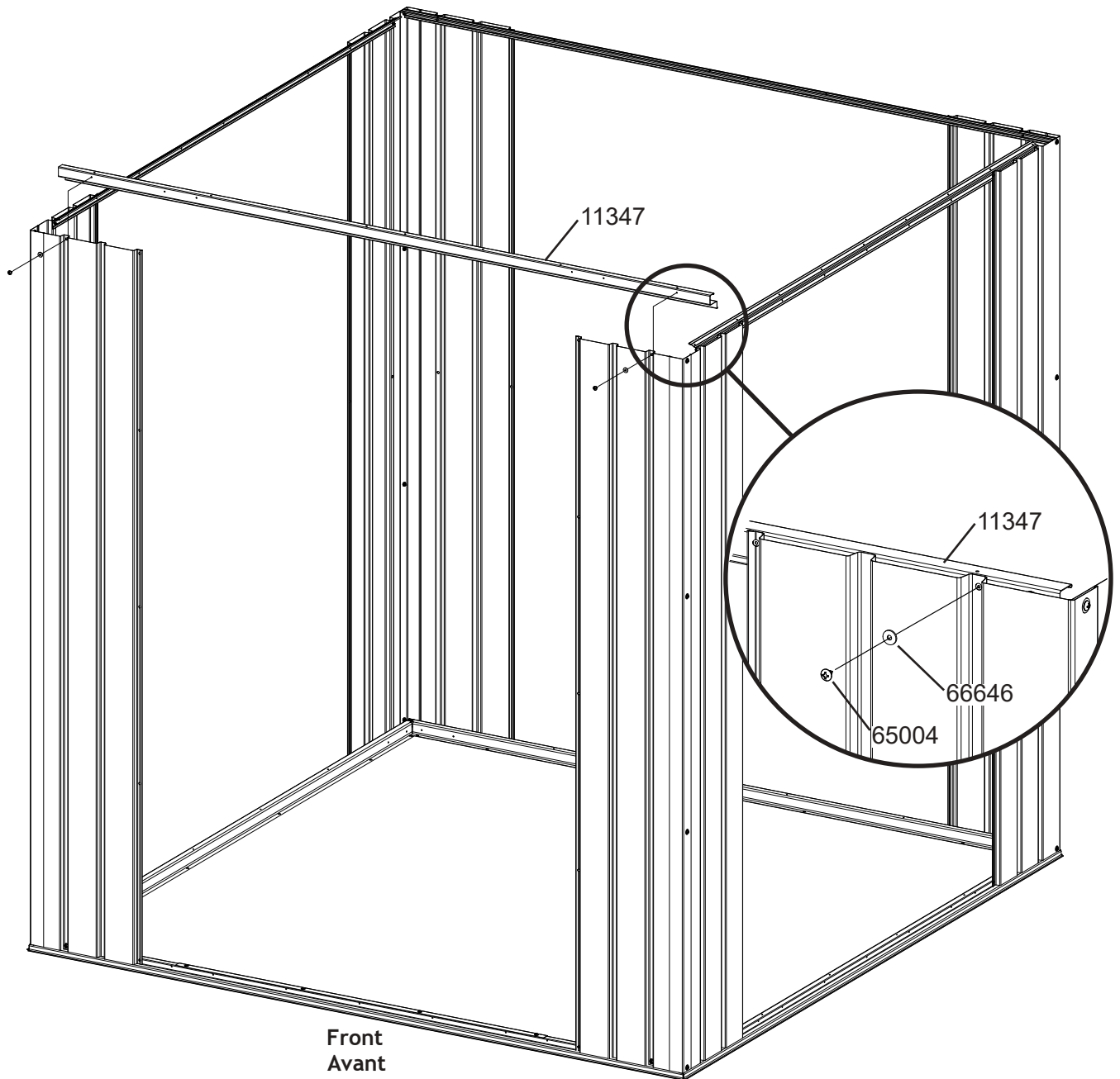
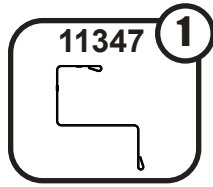
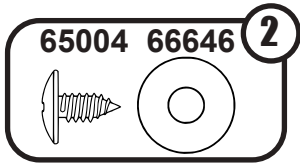

Front
Avant
Frente
Vorne

5: WALL CHANNEL

LONGERON DE MUR
CANALETA DE LA PARED WAND VERSTREBUNG

18HB

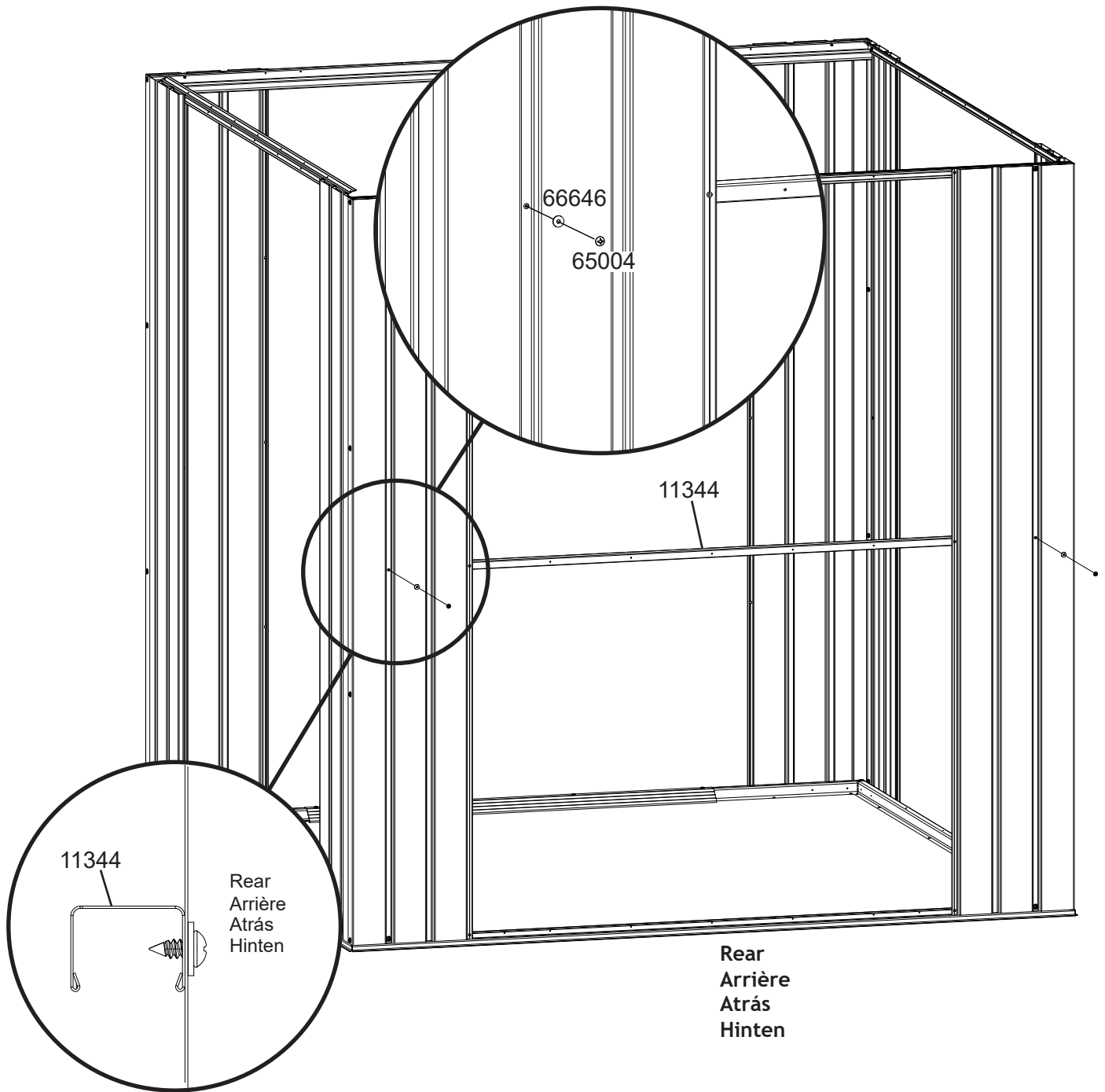
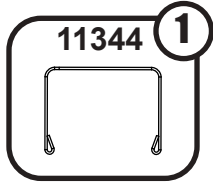
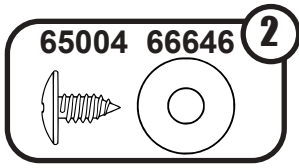

6: WALL PANELS

PANNEAUX DE MUR
PANELES DE LA PARED WANDBLECHE

21HB

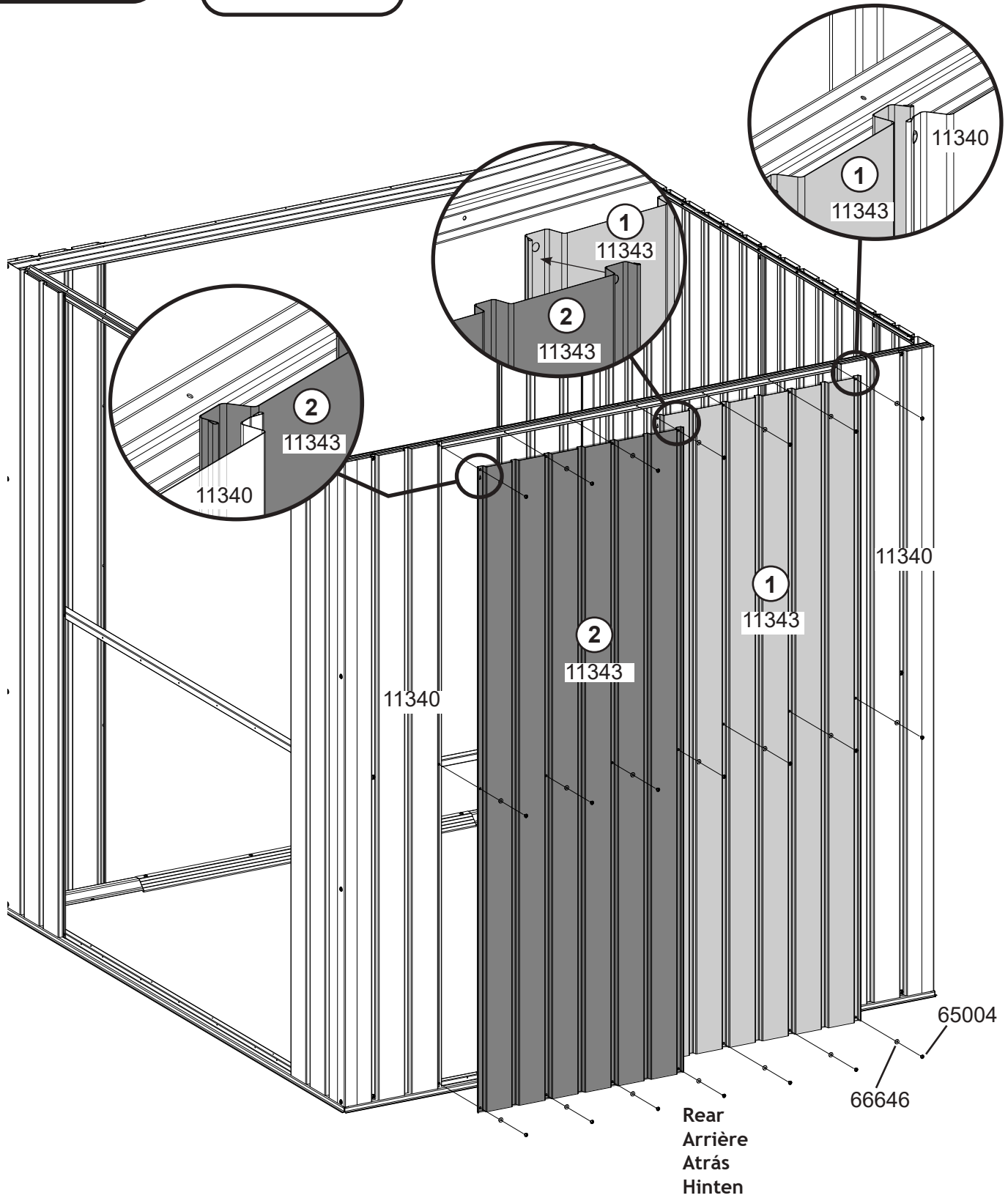
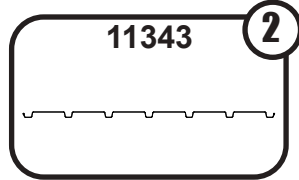
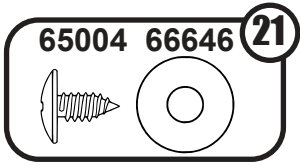

7: DOOR JAMB

JAMBAGE DE PORTE
JAMBA DE LA PUERTA TÜRPFOSTEN

23HB

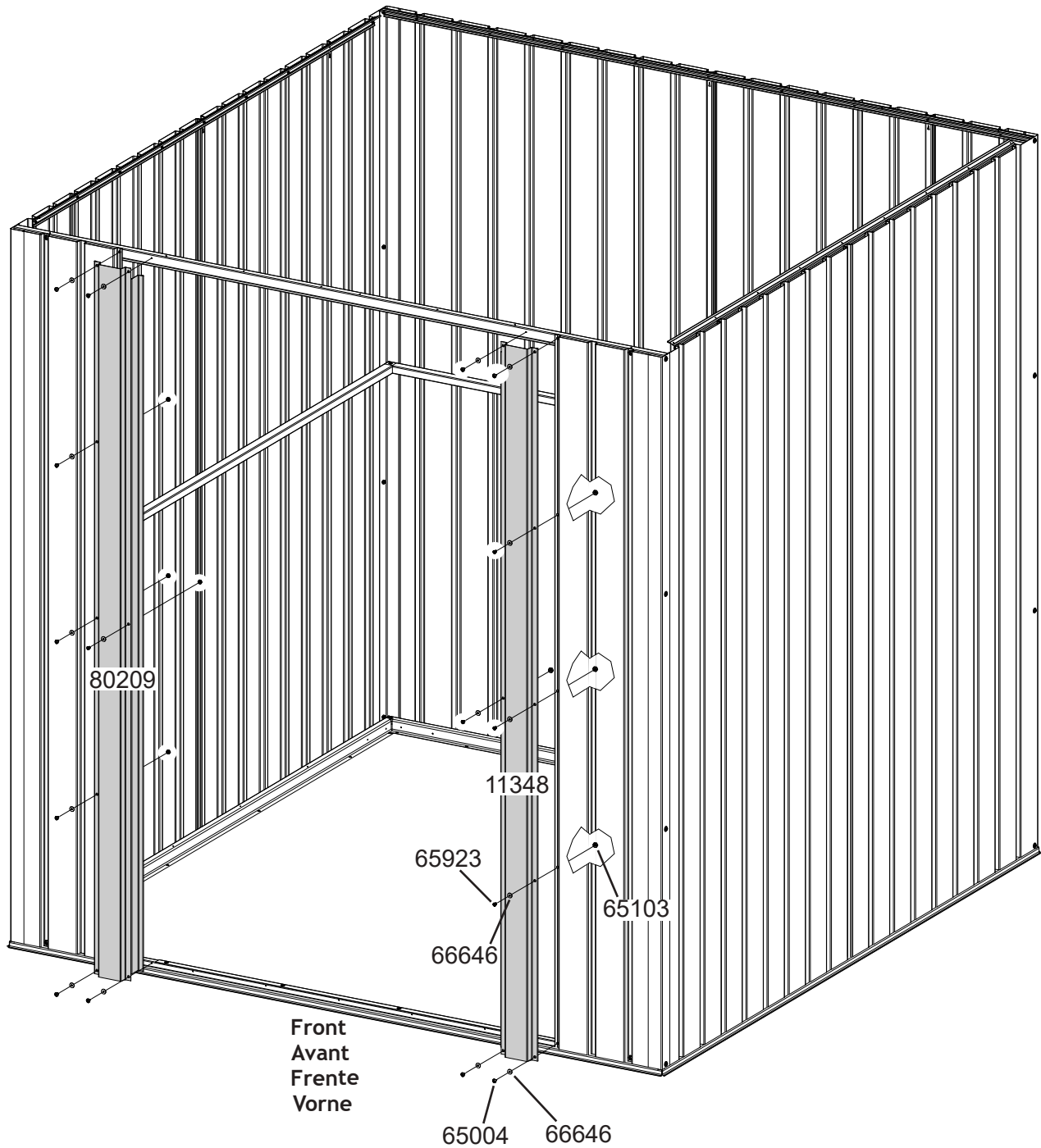
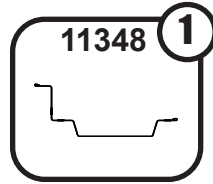
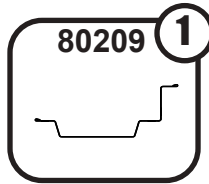
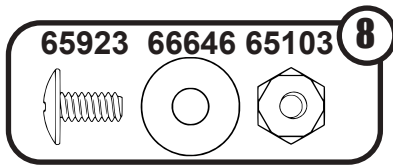
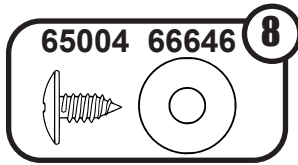

8: GABLES

PIGNON
GABLETE GIEBEL

24HB

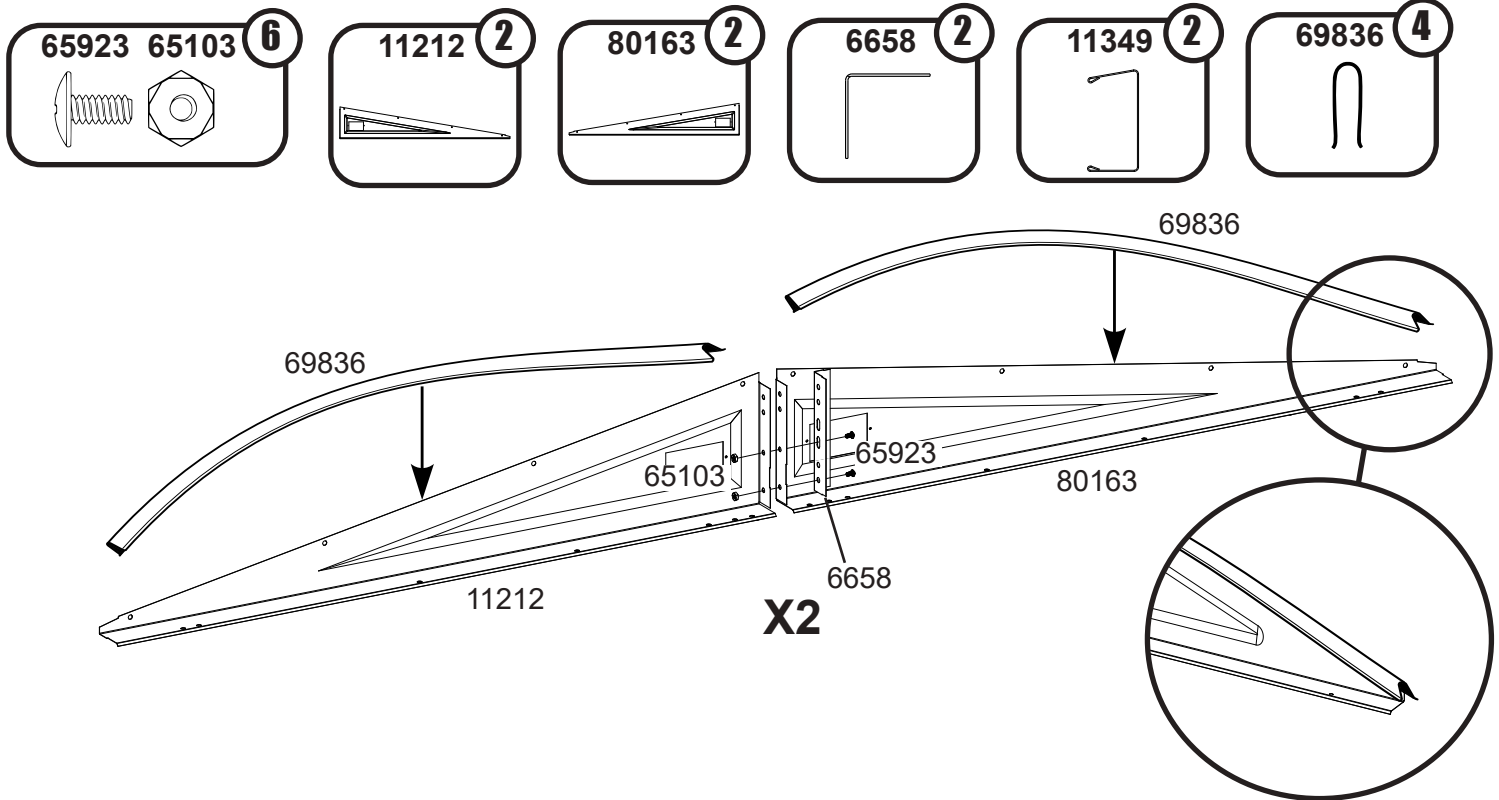

CAUTION:

To avoid mishap on the sharp edge the edge trim must remain in place on the top edge of the gable until right and left roof panels are in place.

PRUDENCE:

Pour éviter les accidents sur l'arête coupante de la garniture de bord, cette garniture doit rester en place sur le bord supérieur du pignon jusqu'à ce que les panneaux de toit droit et gauche soient en place.

ADVERTENCIA:

Para evitar un accidente en el borde filoso, el recuadro del borde debe quedar en su lugar en el borde superior del frontón hasta que los paneles izquierdo y derecho están colocados.

VORSICHT:

Um Unfälle zu vermeiden, sollte die scharfe Kante der Randleiste auf der oberen Kante des Giebels verbleiben, bis die rechten und linken Dachpaneelen angebracht sind.

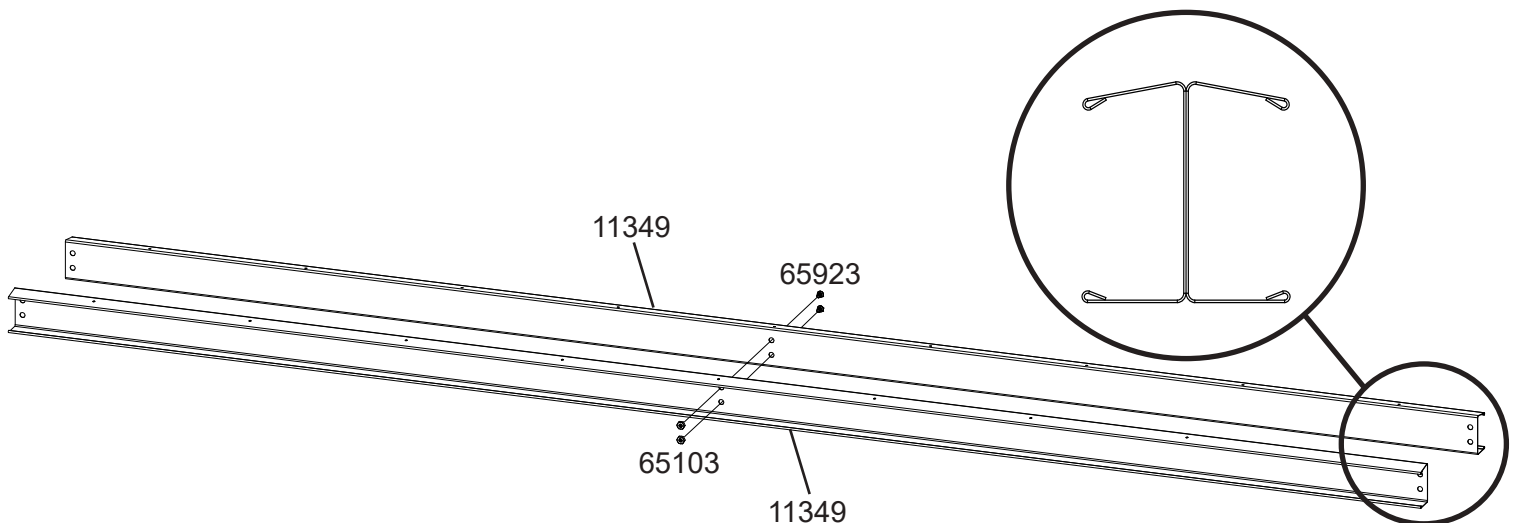

8: GABLES

PIGNON
GABLETE GIEBEL

25HB

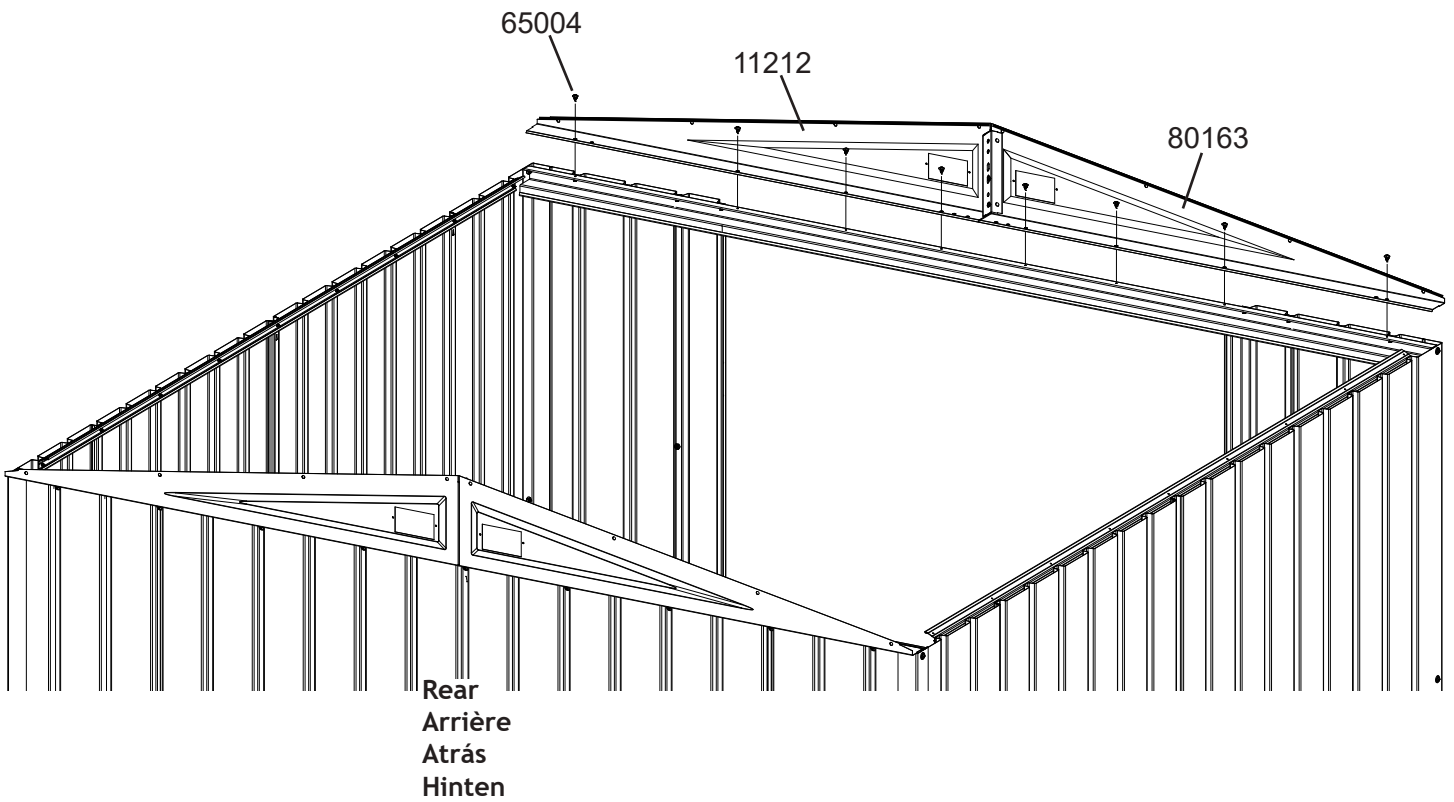
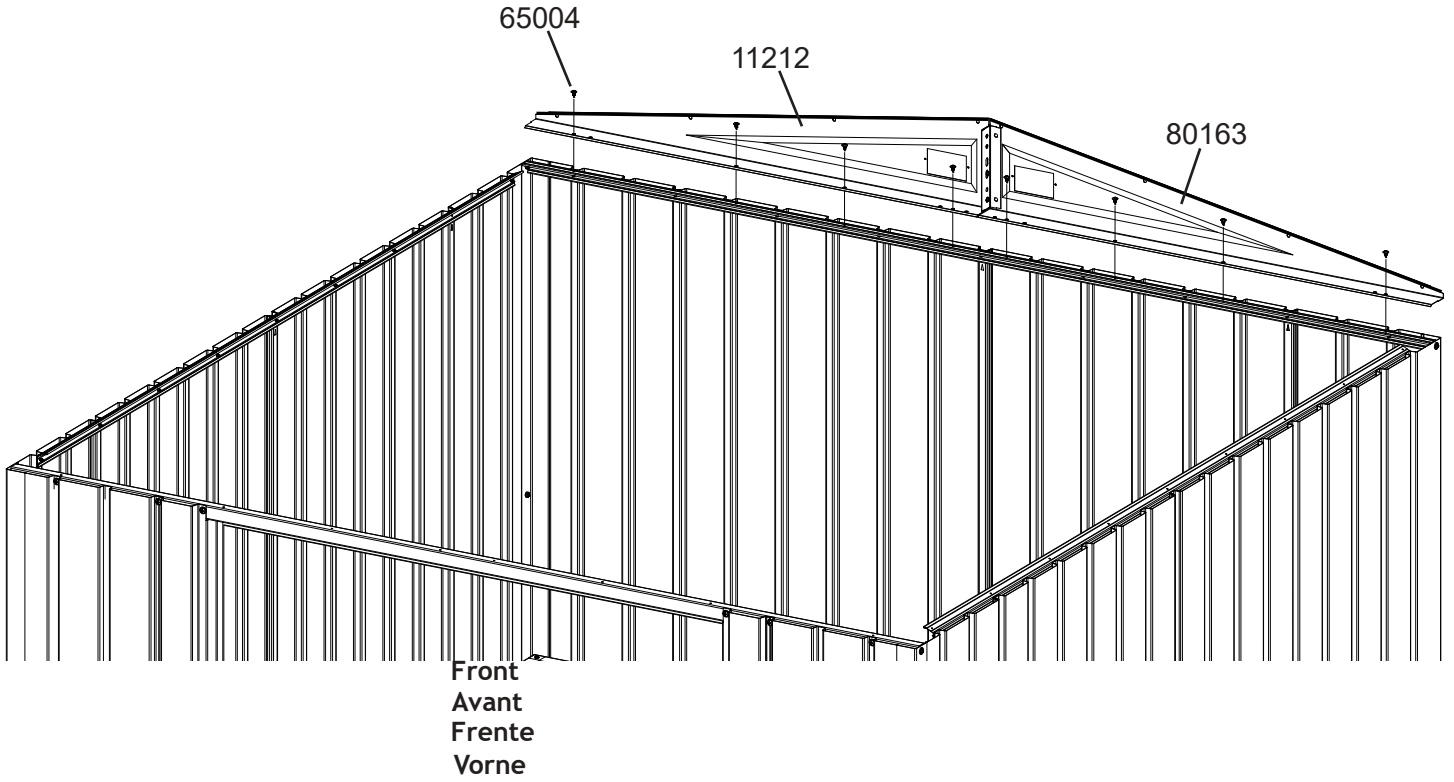
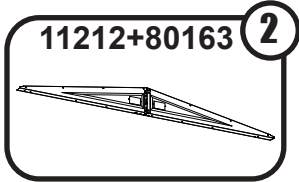
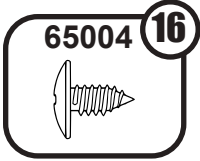

9: ROOF BEAMS

POUTRE DE TOIT
VIGA DEL TECHO DACHTRÄGER

26HB

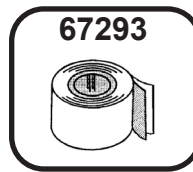
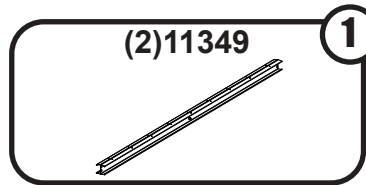
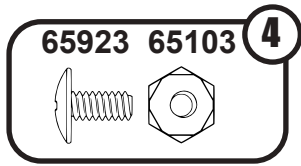

Top View of Gables
Vue de dessus du pignon
Vista superior de gabletes
Draufsicht auf die Giebel

Tape BOTH Gable joints before installing Roof Beams.

Couvrir de ruban le raccord des DEUX pignons avant de poser les poutres du toit.

Coloque cinta adhesiva en AMBAS juntas del gablete antes de instalar las vigas del techo.

Kleben Sie BEIDE Giebelverbindungen zusammen, bevor Sie die Dachbalken montieren.

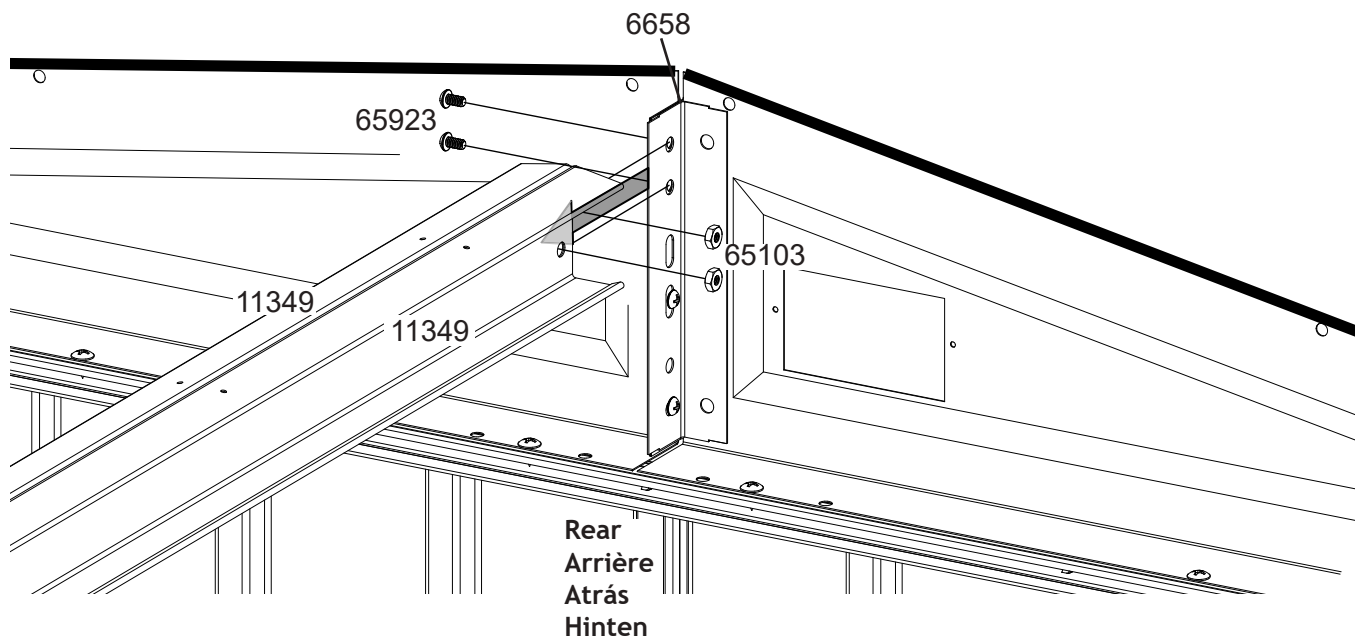
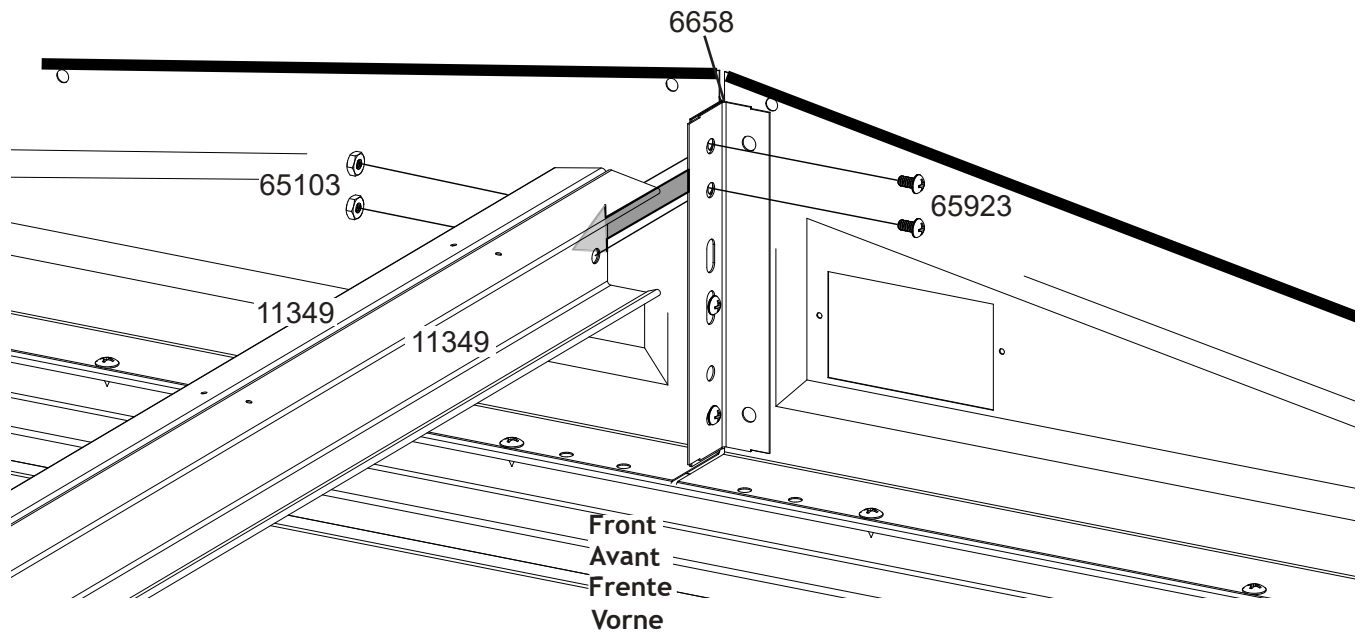
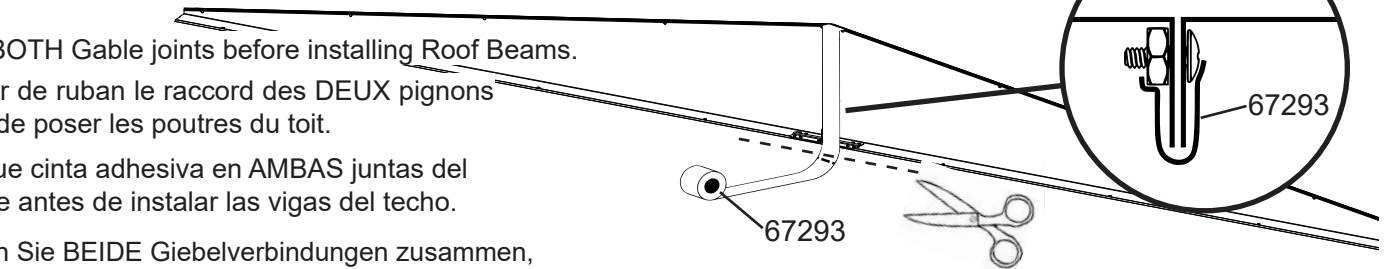

10: ROOF PANELS

PANNEAU DE TOIT
PANEL DEL TECHO DACHBLECH

27HB

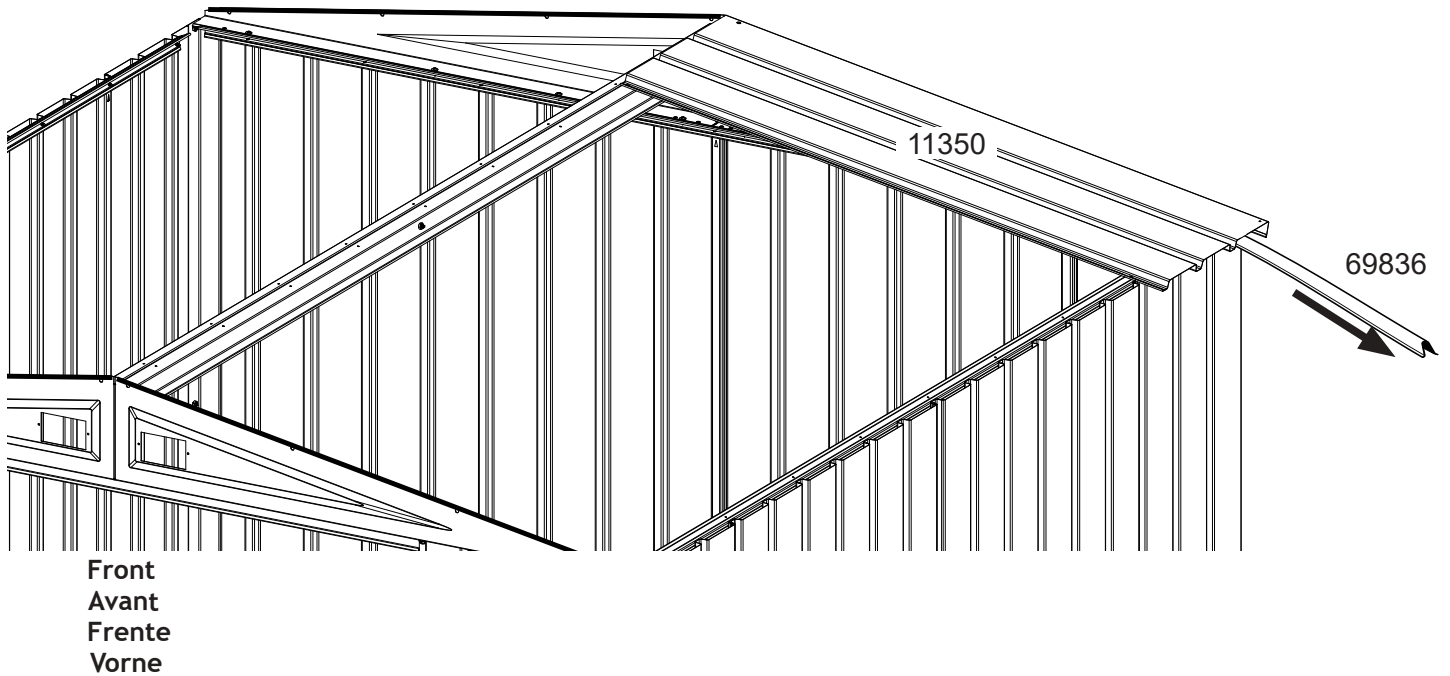
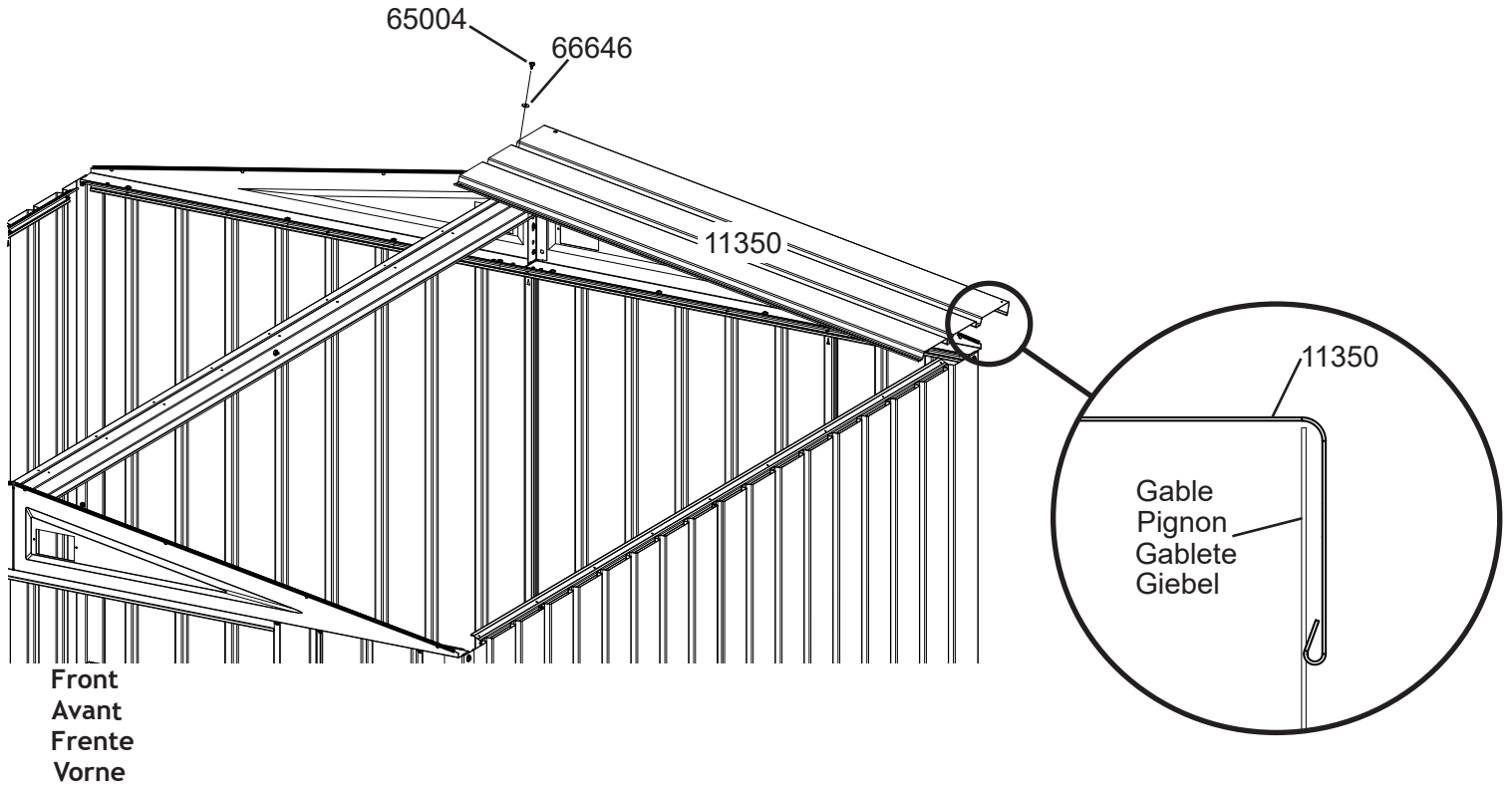
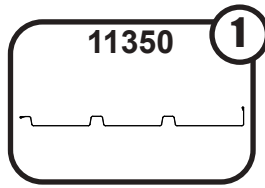
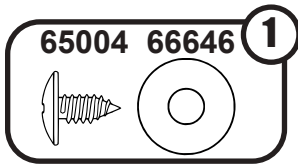

10: ROOF PANELS

PANNEAU DE TOIT
 PANEL DEL TECHO DACHBLECH

28HB

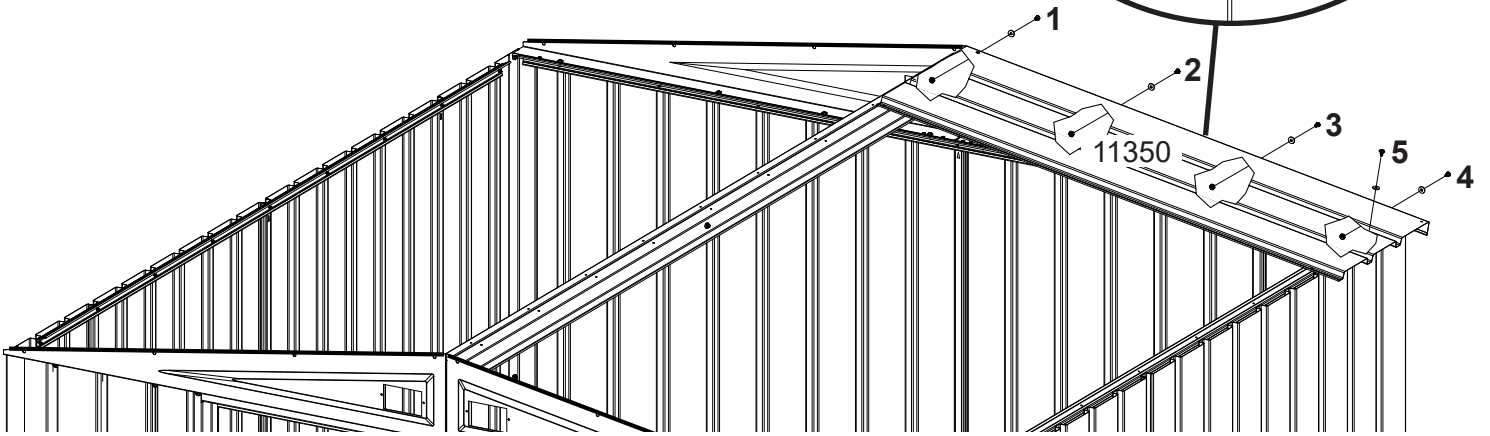
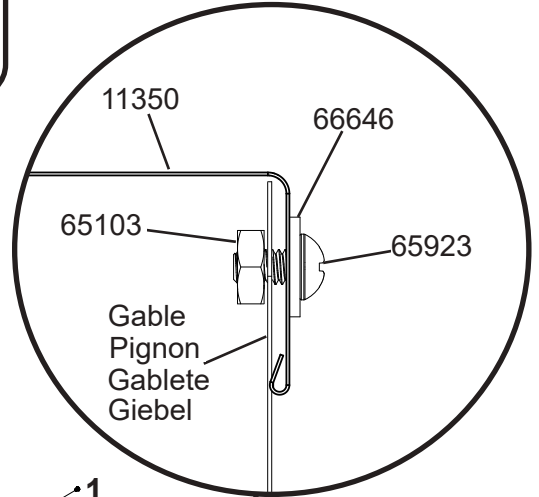
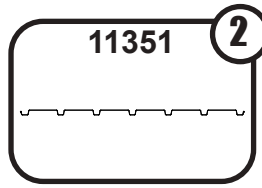
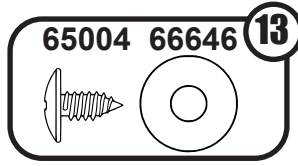
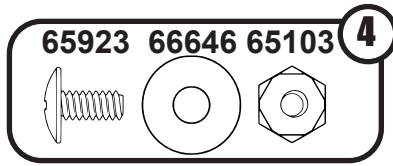

Front
 Avant
 Frente
 Vorne

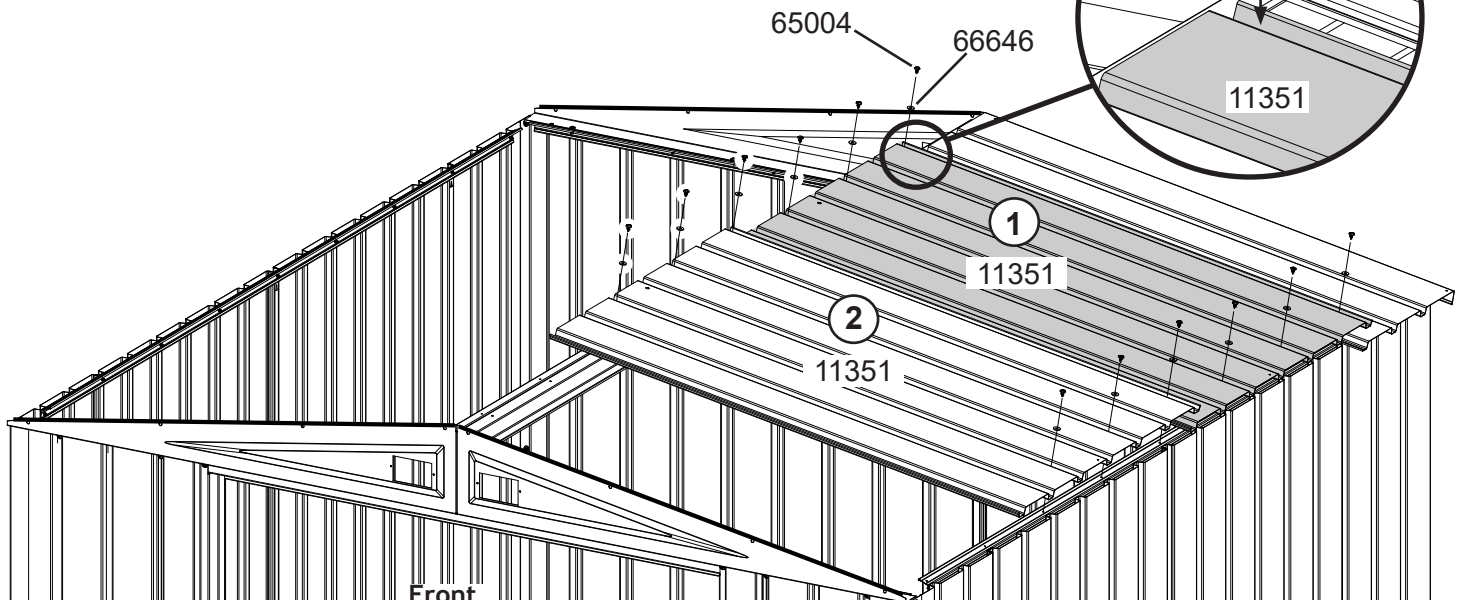
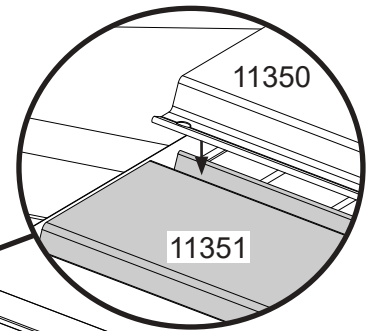

Front
 Avant
 Frente
 Vorne

10: ROOF PANELS

PANNEAU DE TOIT
 PANEL DEL TECHO DACHBLECH

29HB

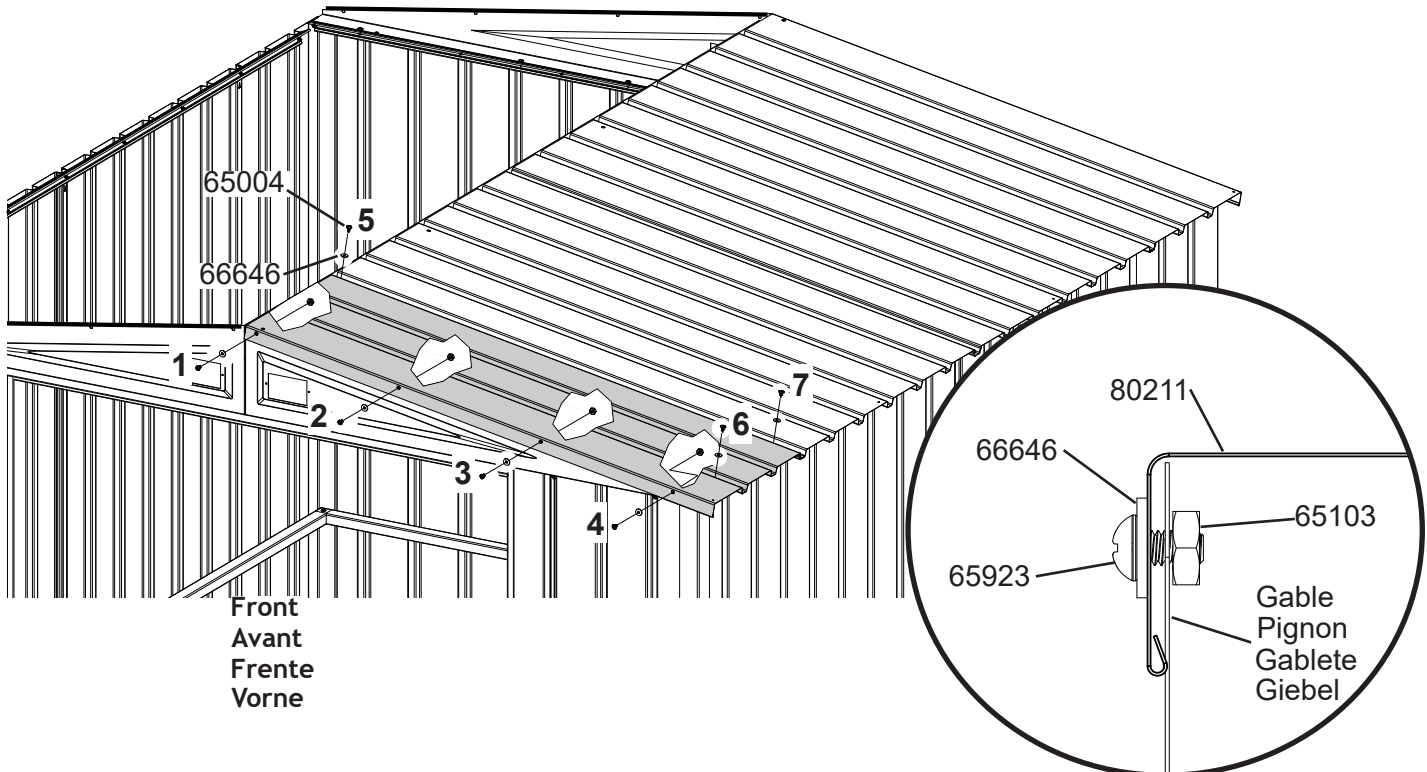
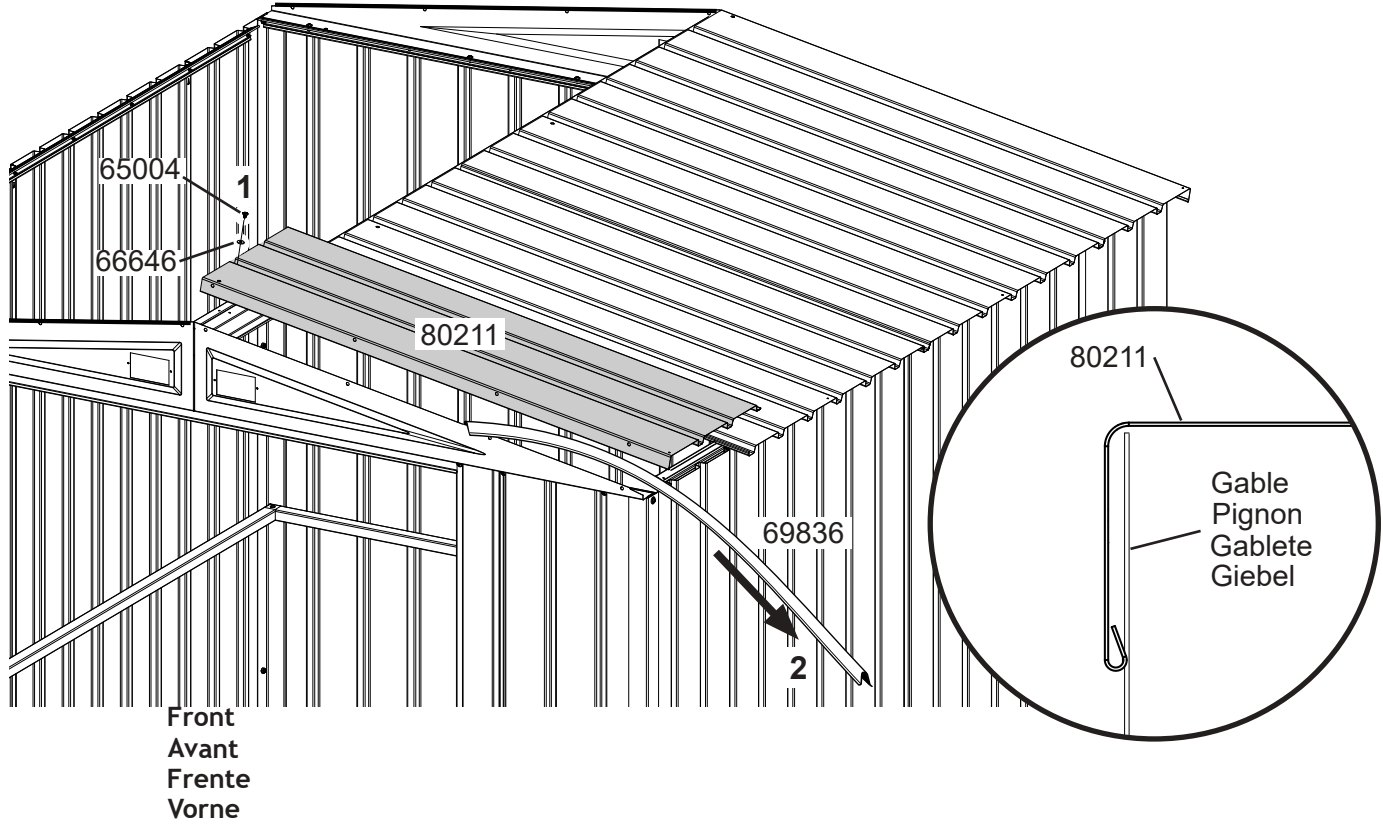
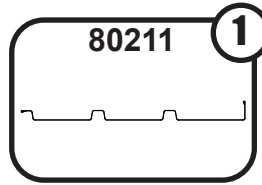
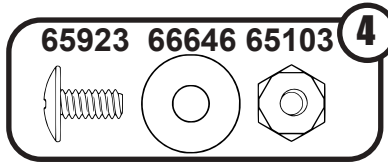
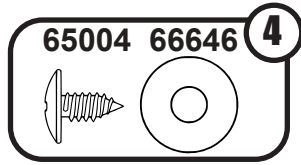

10: ROOF PANELS

PANNEAU DE TOIT
 PANEL DEL TECHO DACHBLECH

30HB

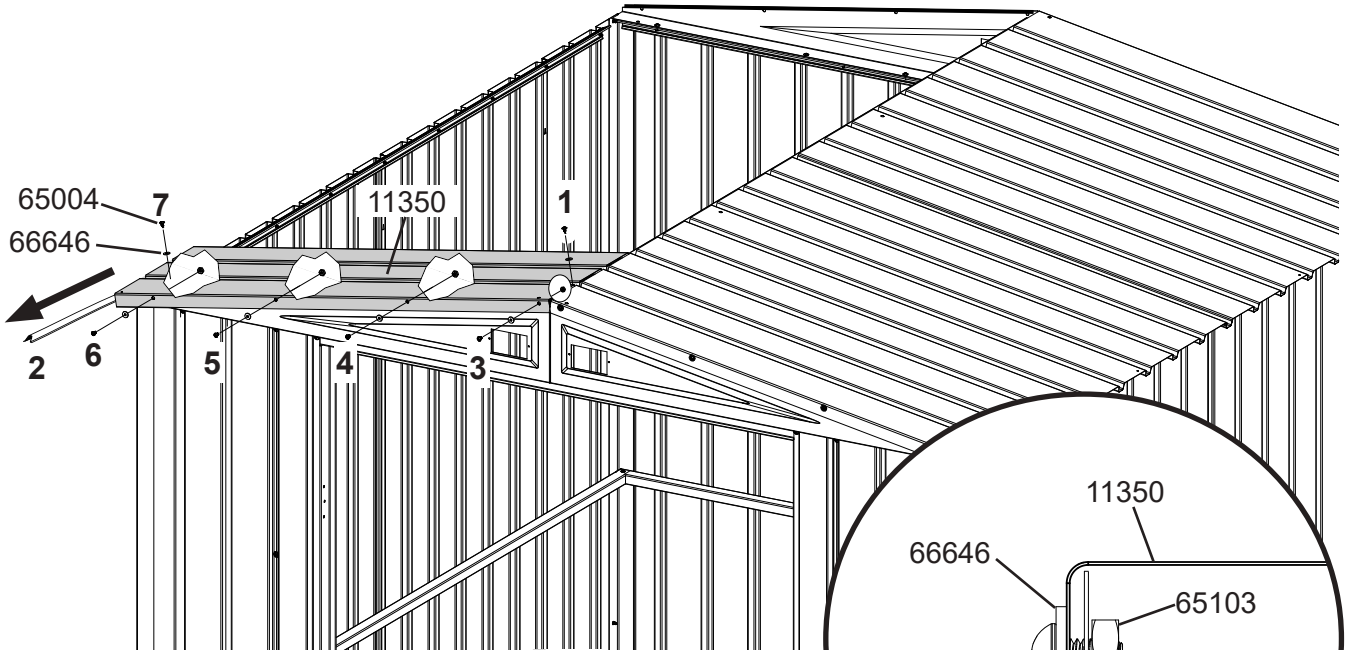
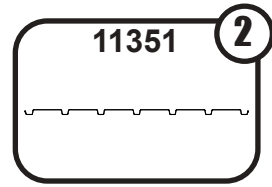
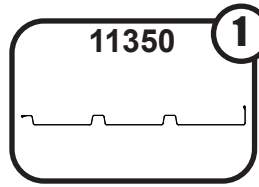
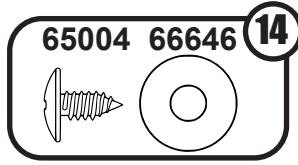
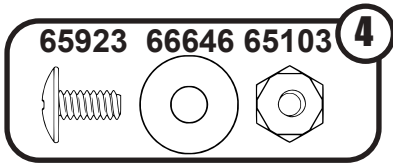

Front
 Avant
 Frente
 Vorne

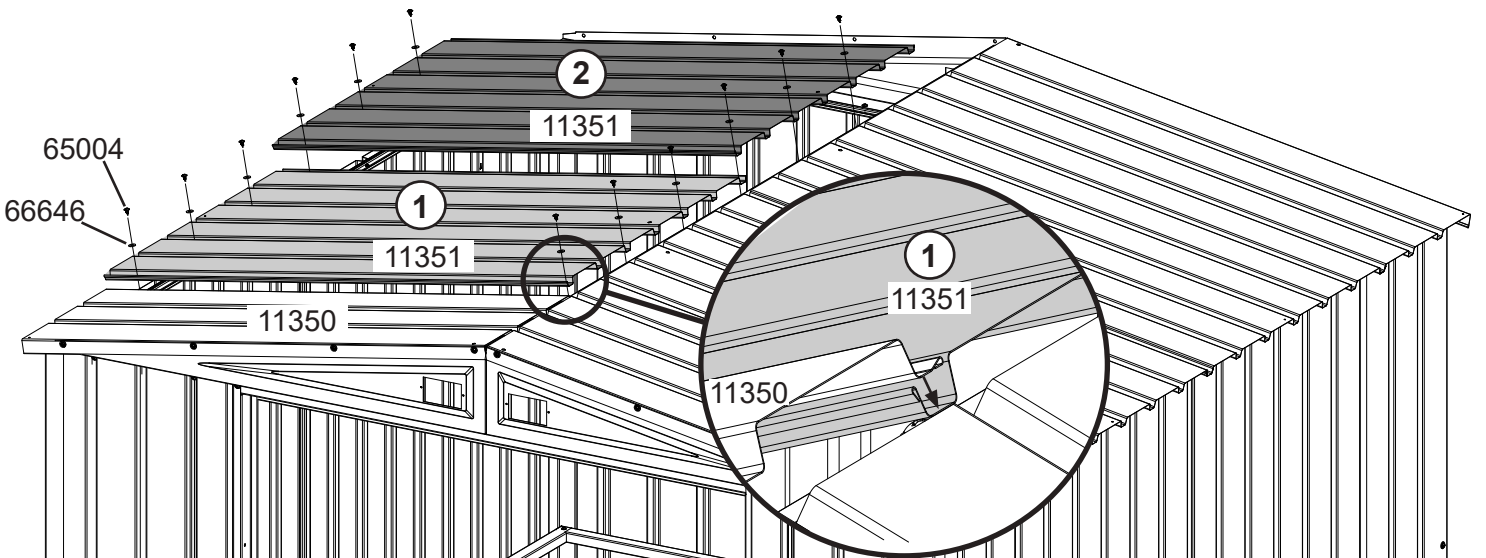
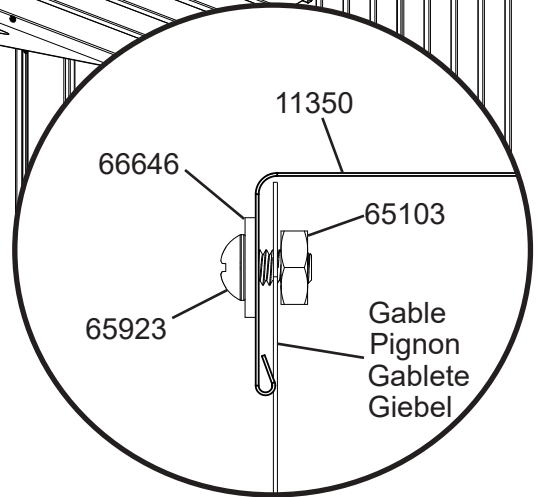

Front
 Avant
 Frente
 Vorne

10: ROOF PANELS

PANNEAU DE TOIT
PANEL DEL TECHO DACHBLECH

31HB

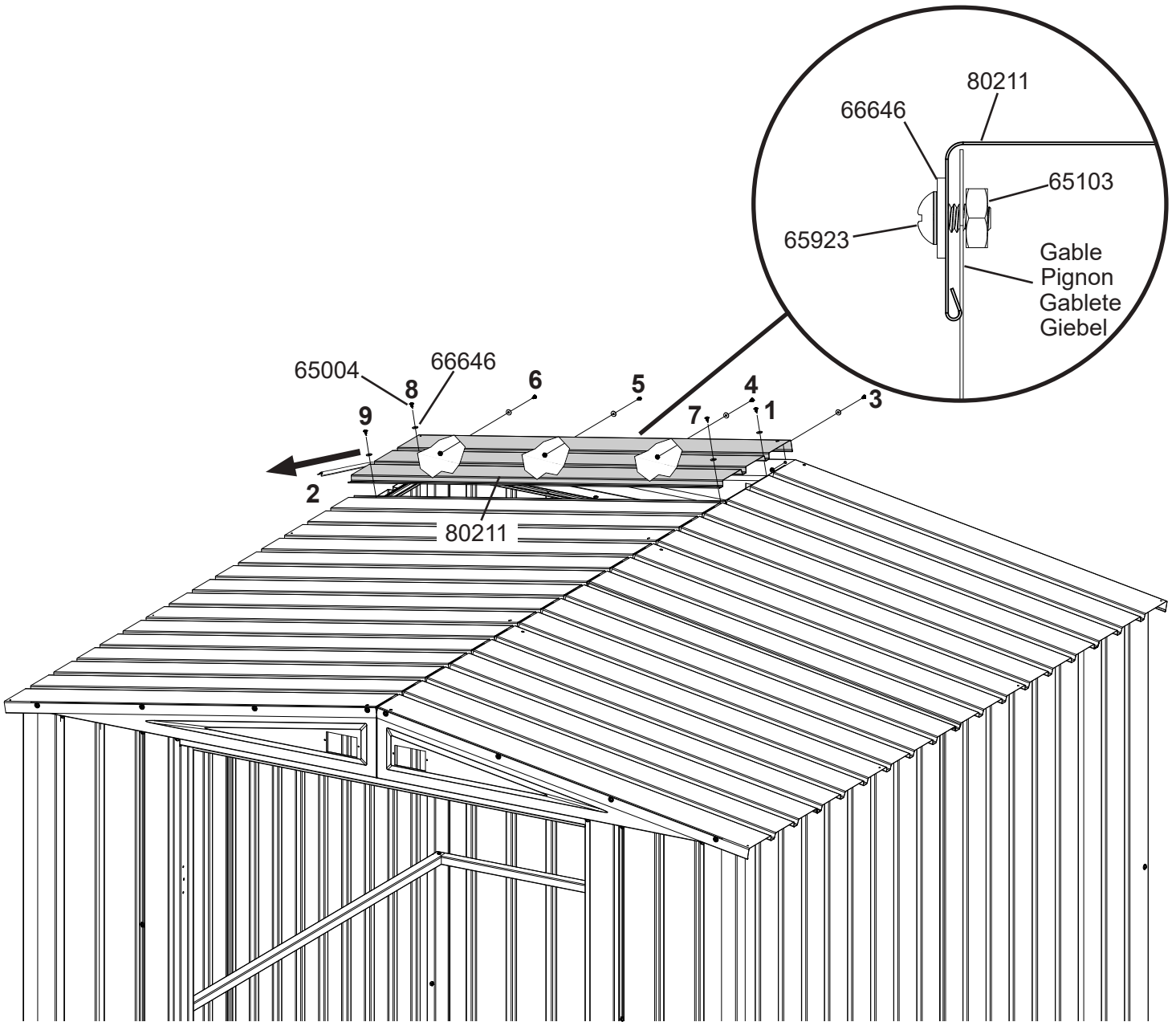
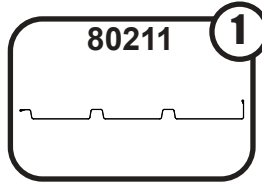
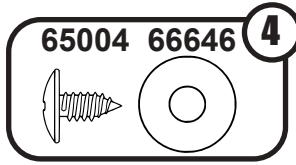
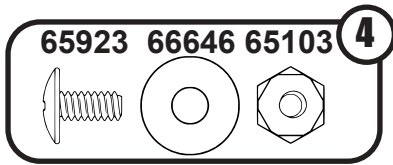

Front
Avant
Frente
Vorne

11: ROOF TRIM

GARNITURE DE TOIT
CONTRAMARCO DEL TECHO DACHABSCHLUSSLEISTE

32HB

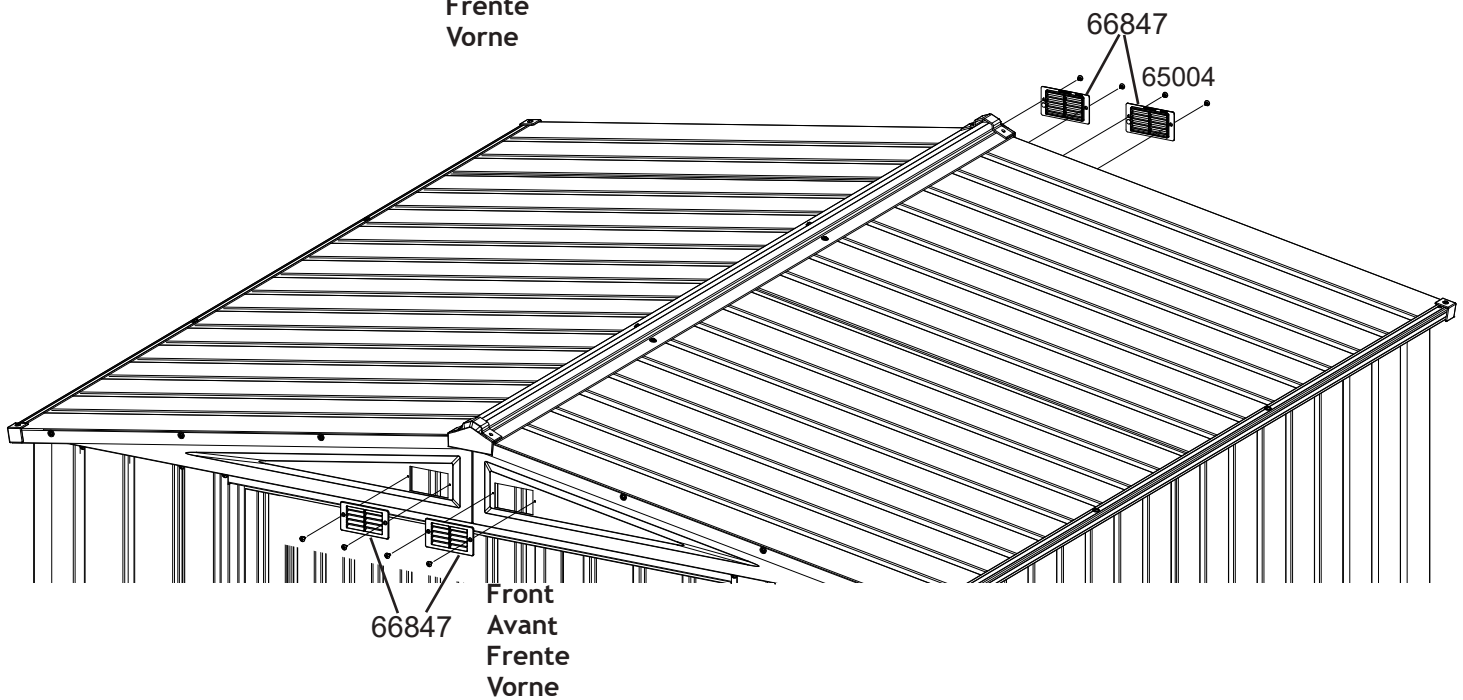
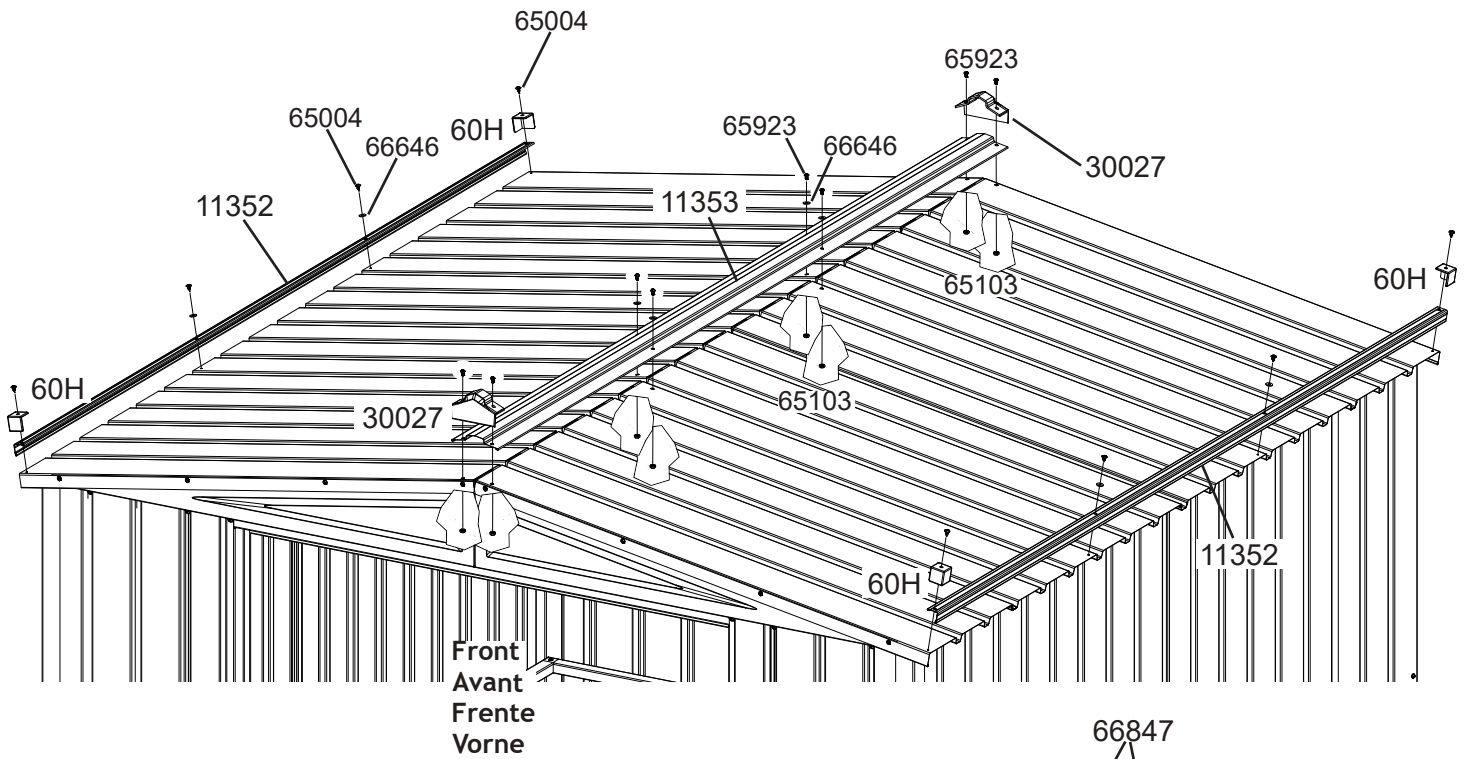
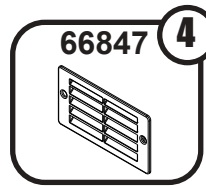
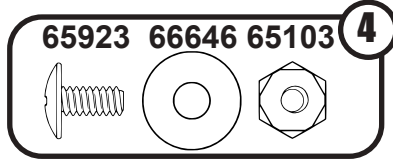
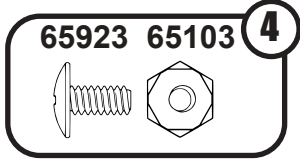
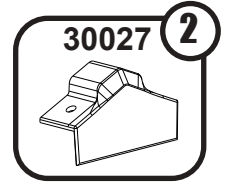
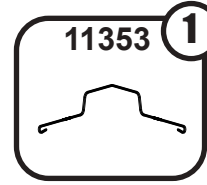
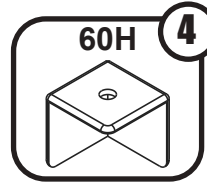
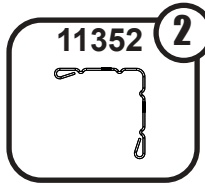
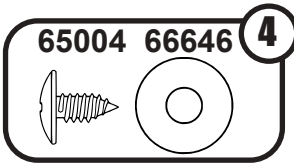
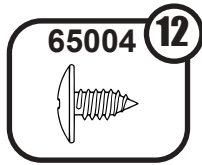

12: DOOR ASSEMBLY

PORTE ASSEMBLÉE
ENSAMBLAJE DE LA PUERTA MONTAGE DER TÜRE

34HB

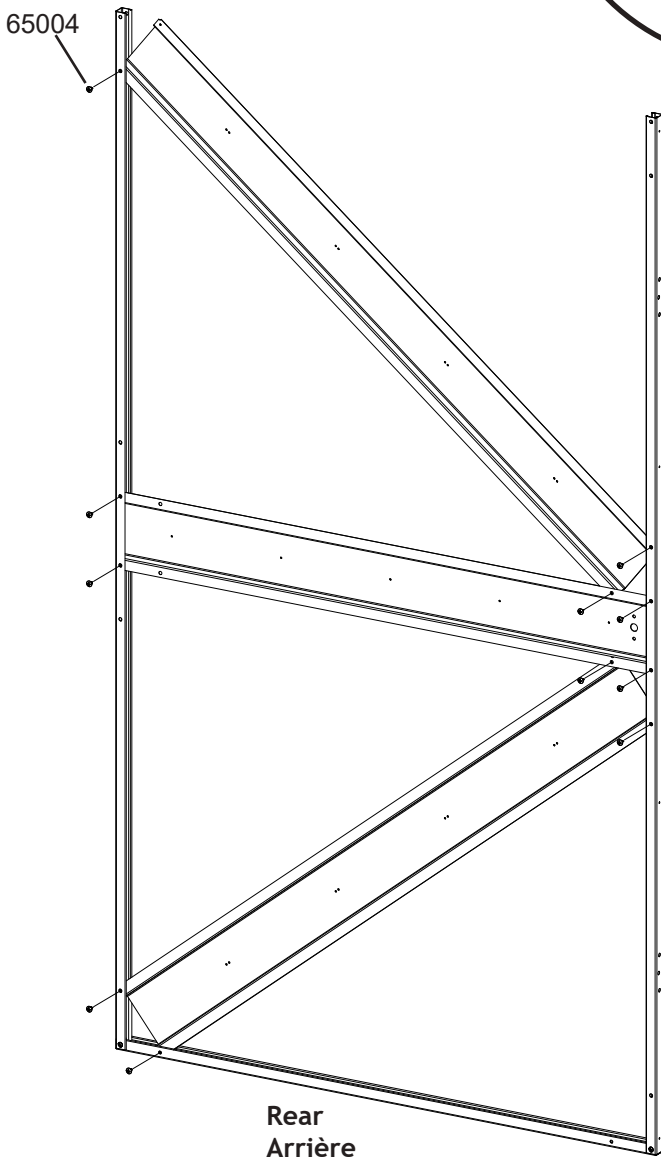
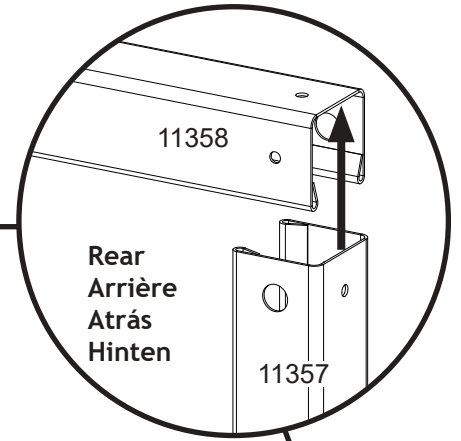
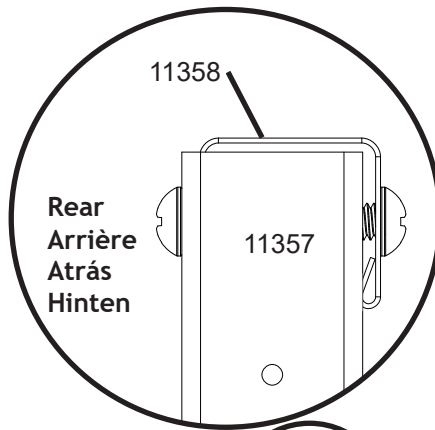
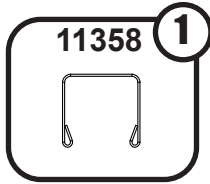
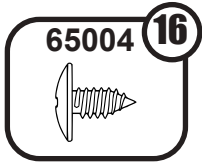

Rear
Arrière
Atrás
Hinten

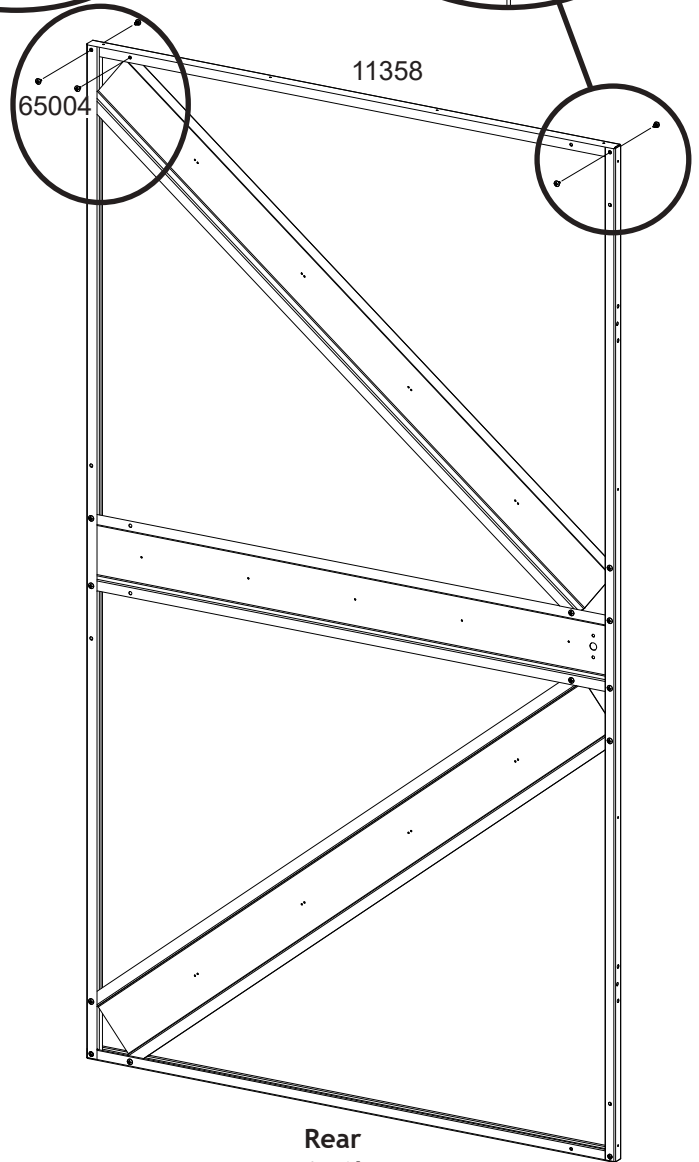

Rear
Arrière
Atrás
Hinten

12: DOOR ASSEMBLY

PORTE ASSEMBLÉE

ENSAMBLAJE DE LA PUERTA MONTAGE DER TÜRE

35HB

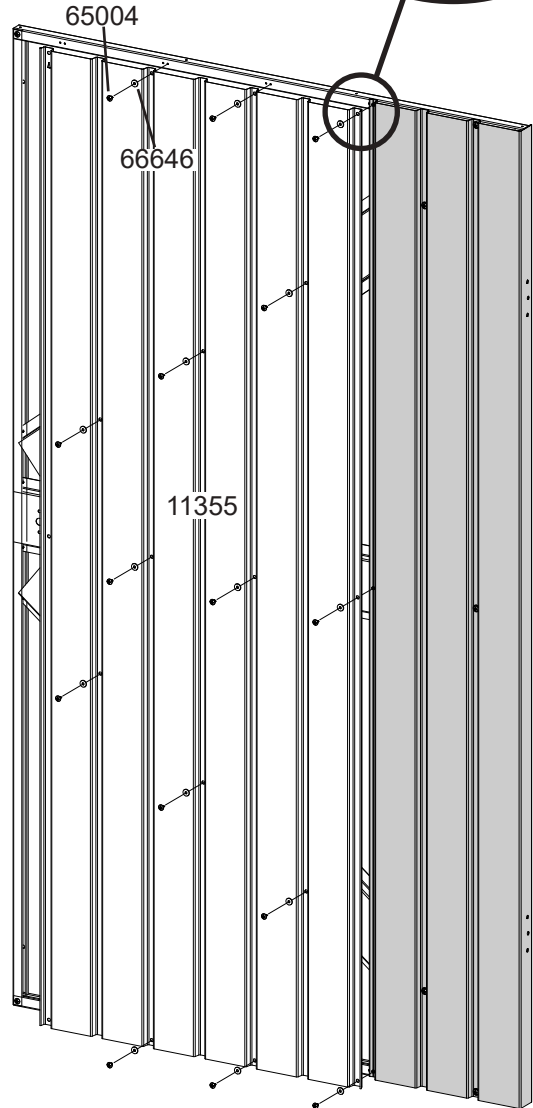
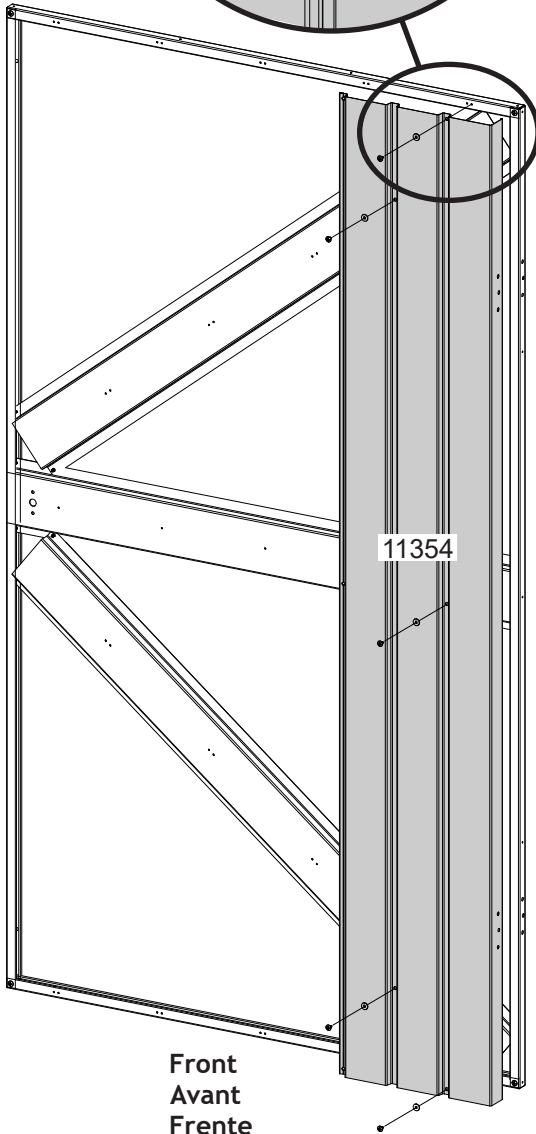
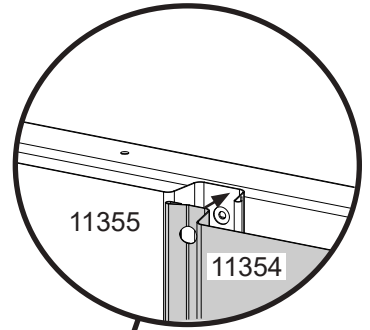
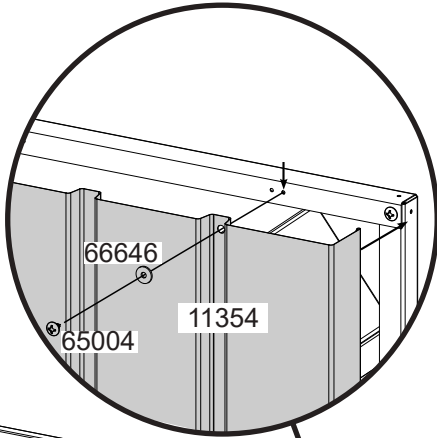
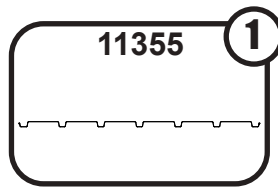
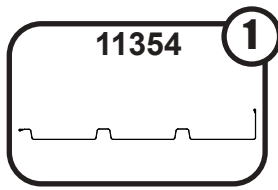
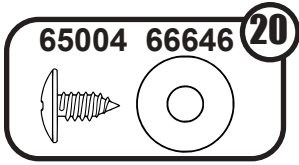

Front
Avant
Frente
Vorne

12: DOOR ASSEMBLY *PORTE ASSEMBLÉE* *ENSAMBLAJE DE LA PUERTA MONTAGE DER TÜRE*

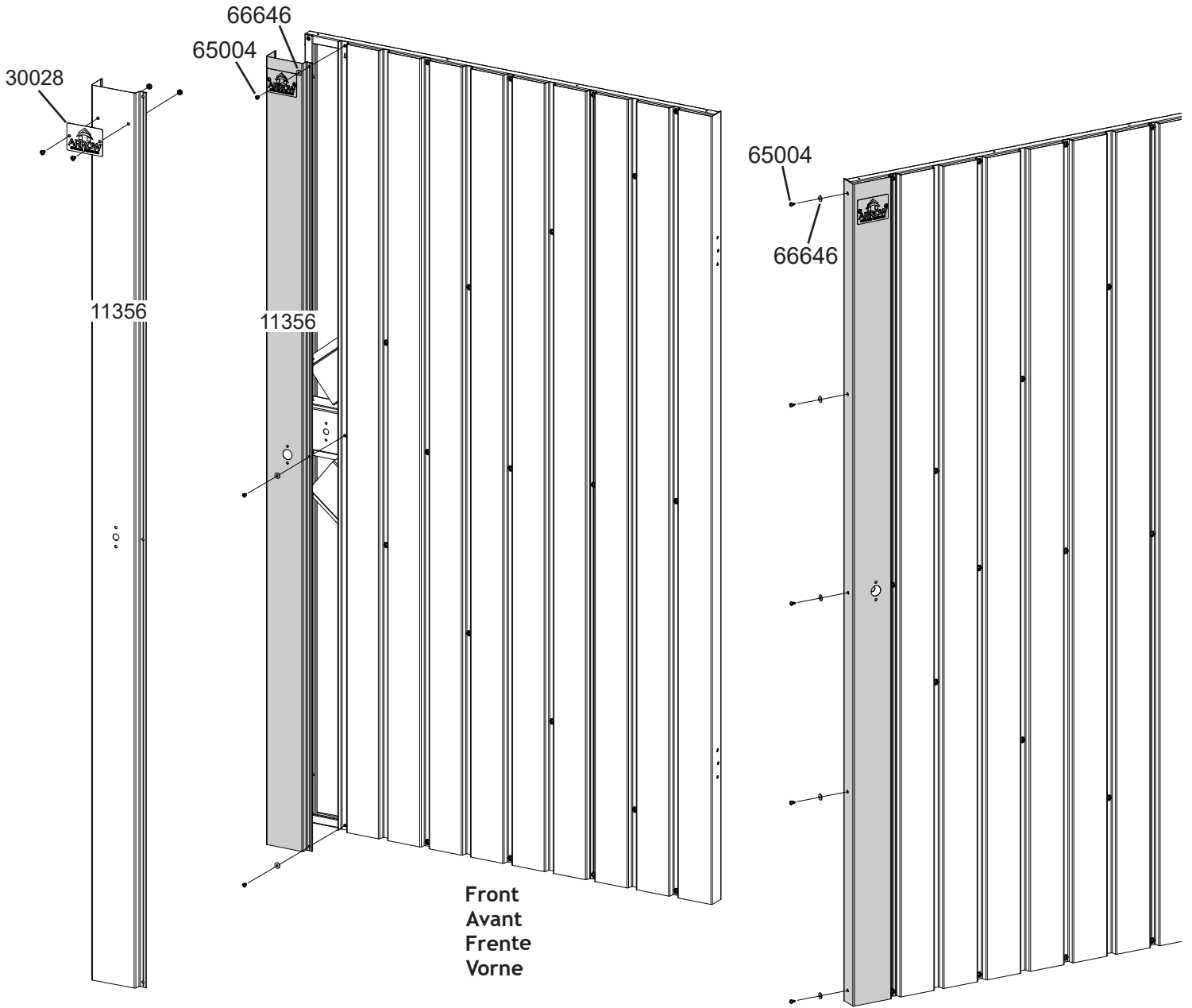
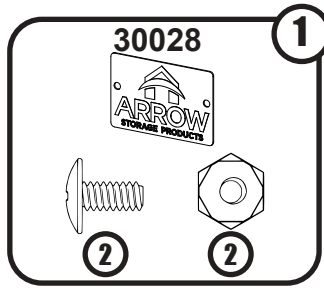
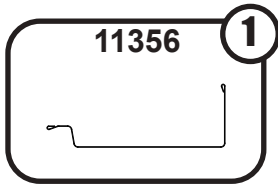
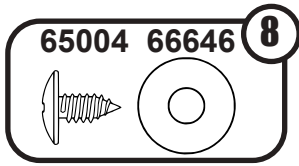

12: DOOR ASSEMBLY *PORTE ASSEMBLÉE* *ENSAMBLAJE DE LA PUERTA MONTAGE DER TÜRE*

37HBa

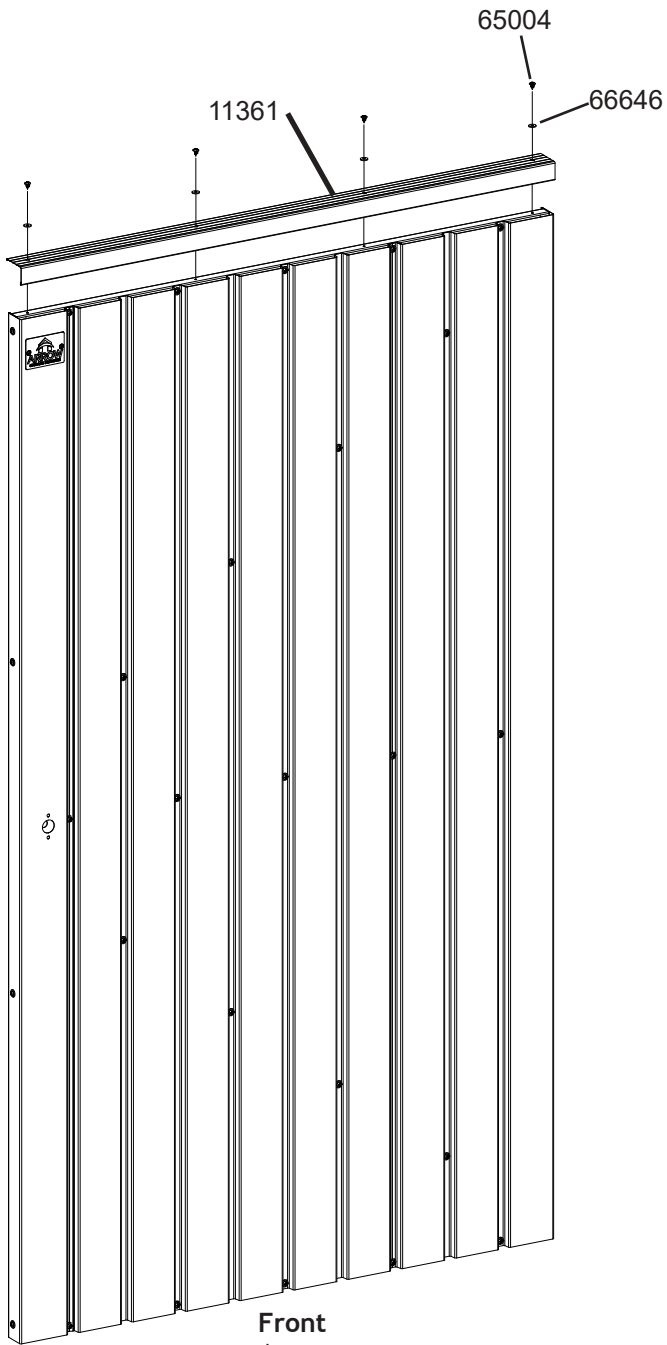
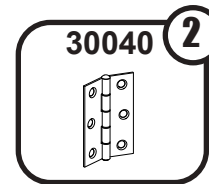
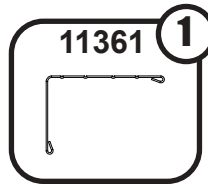
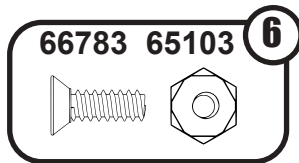
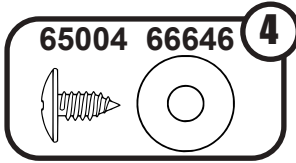

Front
Avant
Frente
Vorne

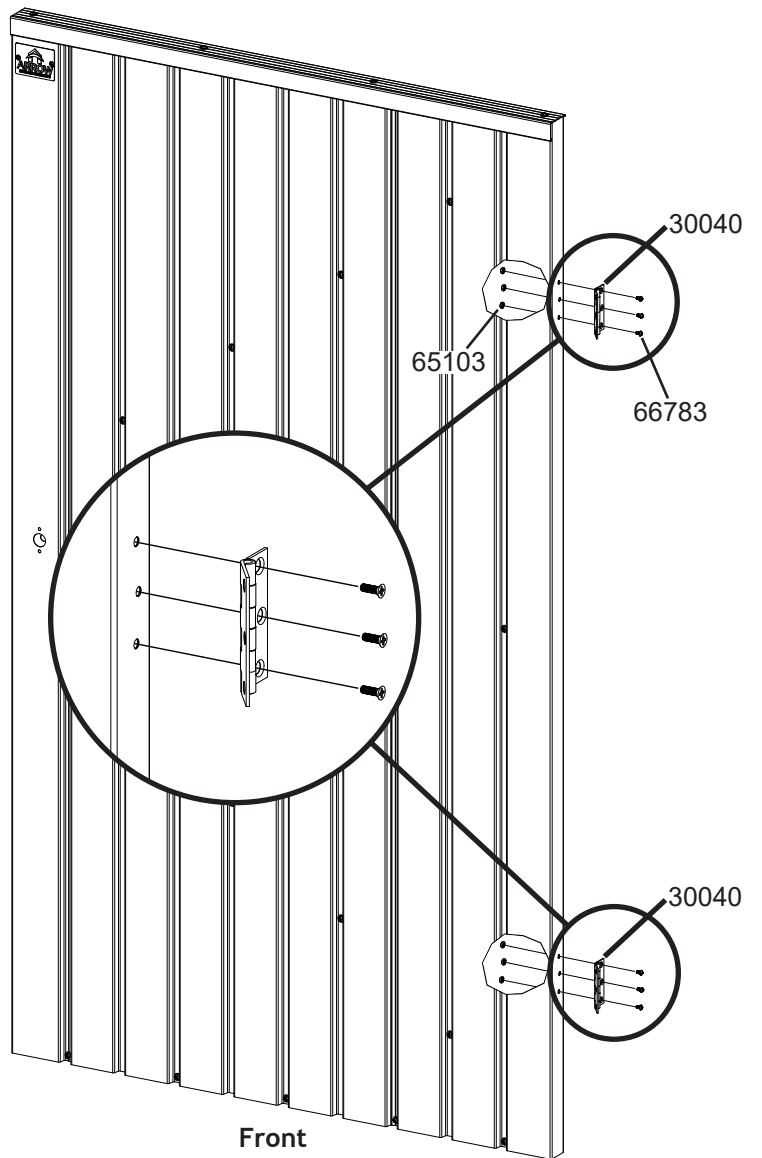

Front
Avant
Frente
Vorne

12: DOOR ASSEMBLY

PORTE ASSEMBLÉE

ENSAMBLAJE DE LA PUERTA MONTAGE DER TÜRE

38HBa

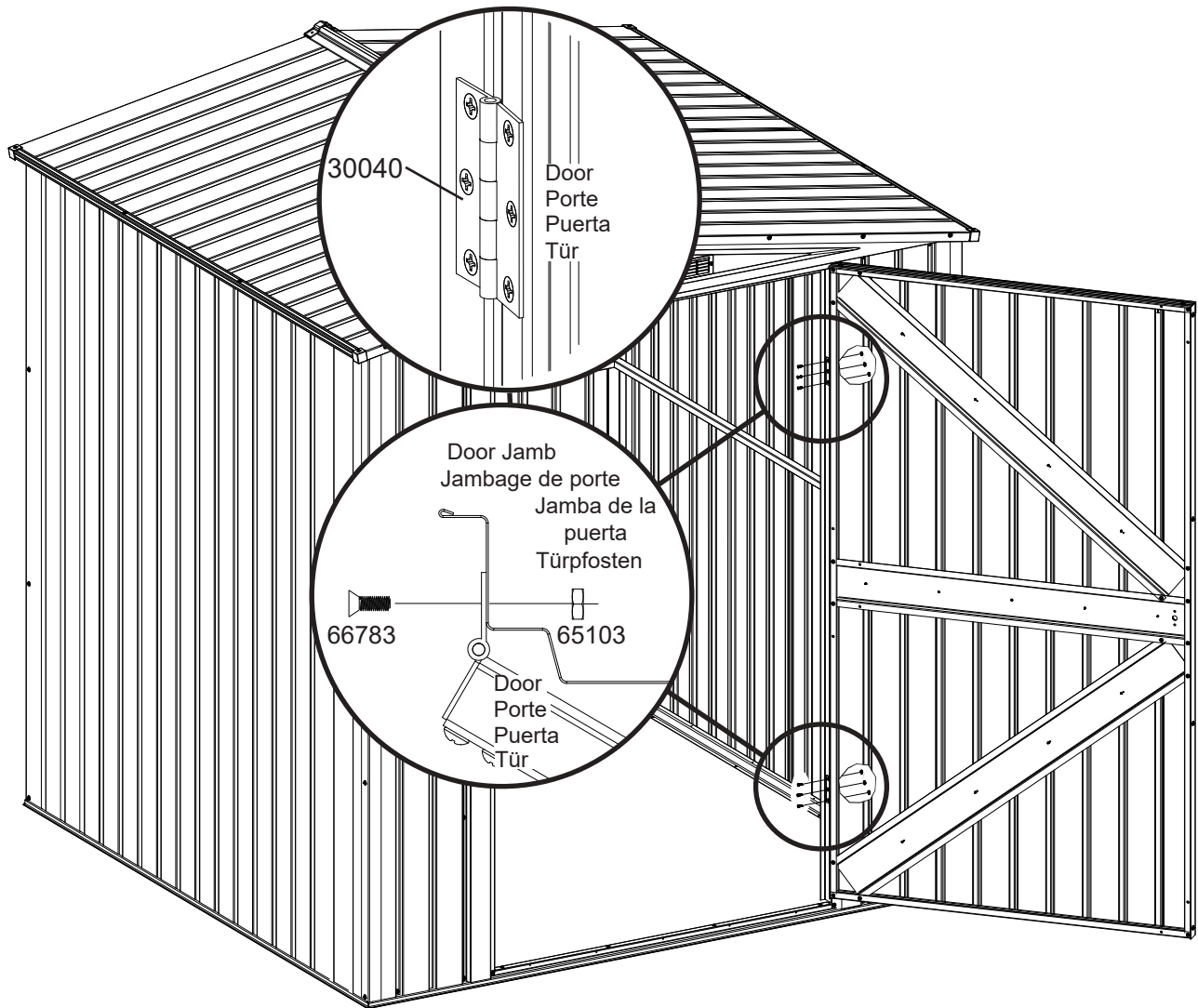
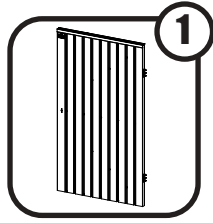
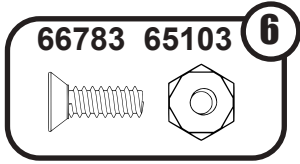

12: DOOR ASSEMBLY *PORTE ASSEMBLÉE* *ENSAMBLAJE DE LA PUERTA MONTAGE DER TÜRE*

39HB

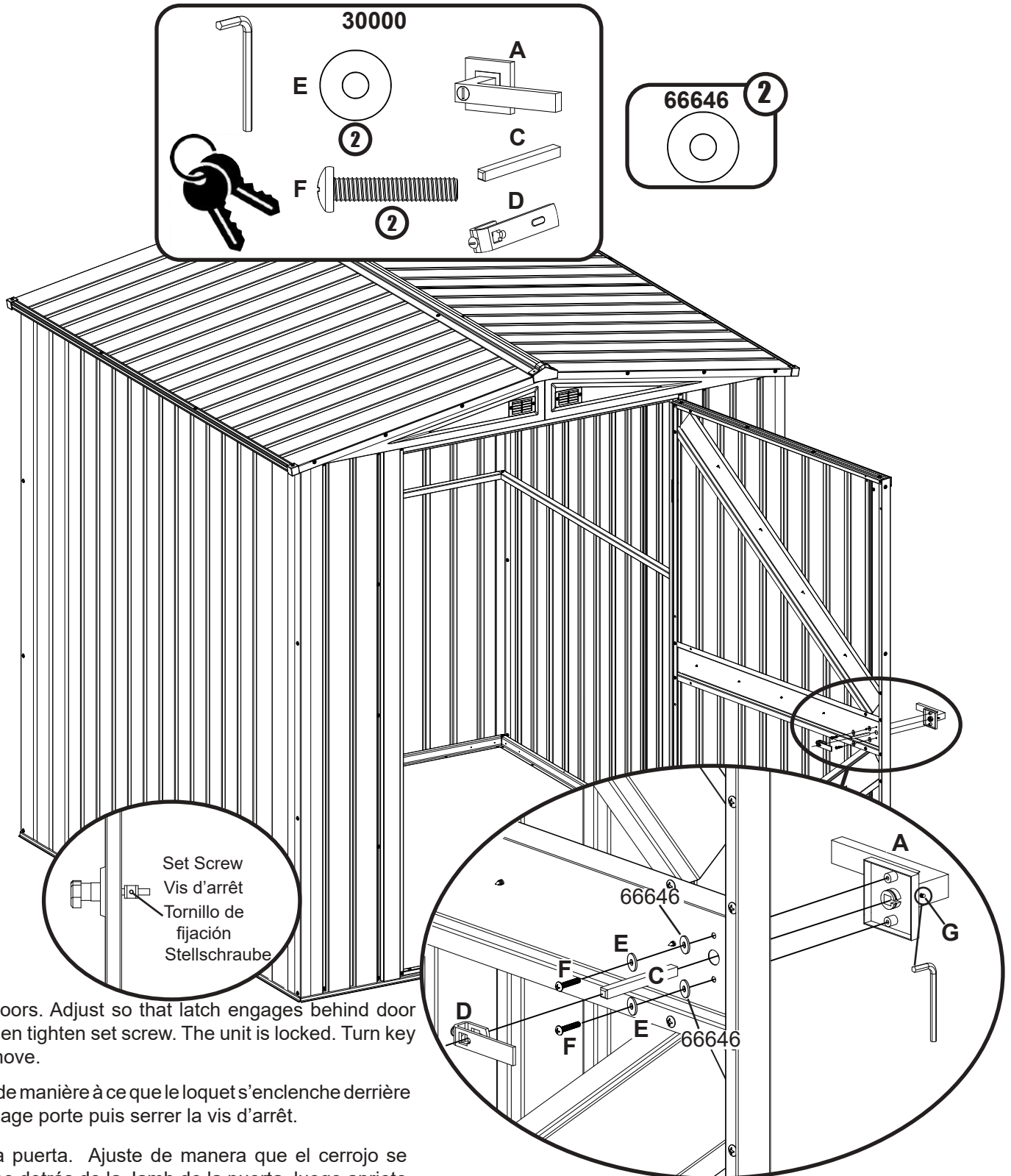

Close doors. Adjust so that latch engages behind door jamb, then tighten set screw. The unit is locked. Turn key and remove.

Ajuster de manière à ce que le loquet s'enclenche derrière la Jambage porte puis serrer la vis d'arrêt.

Cierre la puerta. Ajuste de manera que el cerrojo se enganche detrás de la Jamb de la puerta, luego apriete el juego de tornillos. La unidad está trancada. Voltee la llave y la retira.

Schließen Sie die Türen. Nehmen Sie Anpassungen vor, sodass die Verriegelung hinter der linken Tür einrastet, dann ziehen Sie die Stellschraube fest. Die Einheit ist abgeschlossen. Drehen Sie den Schlüssel um und ziehen Sie ihn heraus.

Washer 66646 NOT supplied with 30001 handle kit.
Rondelle 66646 NON fournie avec le kit de poignée 30001.
Arandela 66646 NO suministrada con el kit de mango 30001.
Unterlegscheibe 66646 NICHT im Lieferumfang des Griffsatzes 30001 enthalten.

*** IMPORTANT ***

- *If you have swing doors, they must hang and swing level before anchoring building.*
- *Anchor your building at this time. Use appropriate 1/4"(6mm) X 1 1/2"(38,1mm) length hardware.*
- *Please take a moment to ensure that the building is installed in accordance with these instructions and with all applicable regulations.*
- *The entire floor frame MUST be securely anchored once the building is erected.*

*** IMPORTANT ***

- *Si l'abri comporte des portes battantes, vérifier qu'elles sont accrochées de niveau et pivotent librement avant d'ancrer l'ouvrage.*
- *Ancrez votre bâtiment en ce moment. Utilisez une longueur appropriée de 1/4 po (6 mm) X 1 1/2 po (38,1 mm) Matériel.*
- *Veiller à bien s'assurer que l'abri est installé conformément aux présentes instructions et à toute la réglementation en vigueur.*
- *Le cadre de plancher entier doit IMPÉRATIVEMENT être solidement ancré une fois que l'abri est assemblé.*

*** IMPORTANTE ***

- *Si tiene puertas vaivén, estas deben colgar y moverse en forma pareja antes de sujetar el cobertizo.*
- *Ancle su edificio en este momento. Use una herramienta apropiada de 1/4 "(6 mm) X 1 1/2" (38,1 mm) de longitud.*
- *Dedique unos minutos a asegurarse de que la estructura está instalada de acuerdo con estas instrucciones y con las reglamentaciones vigentes.*
- *Se DEBE anclar todo el tirante del piso cuando la estructura está erguida.*

WICHTIG

- *Wenn Sie Schwingtüren haben, müssen diese sauber hängen und schwingen, bevor der Schuppen verankert wird.*
- *Verankern Sie Ihr Gebäude zu diesem Zeitpunkt. Verwenden Sie angemessene Teile der Länge 1/4"(6mm) X 1 1/2" (38,1mm).*
- *Bitte überprüfen Sie noch einmal, ob der Schuppen im Einklang mit dieser Anleitung und mit allen geltenden Vorschriften aufgestellt wurde.*
- *Nach Aufstellung des Geräteschuppens MUSS der gesamte Bodenrahmen sicher verankert werden.*

