

90259000

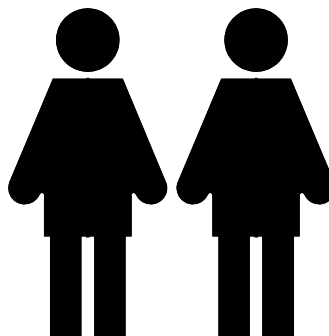
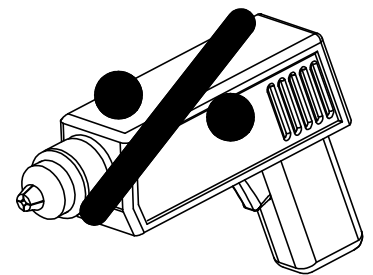
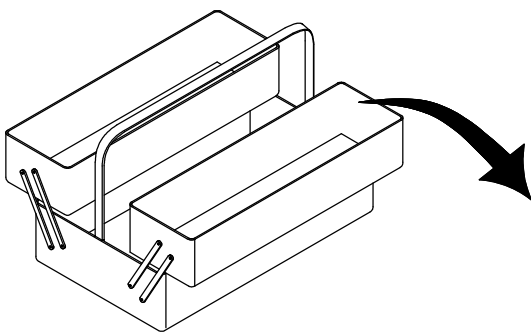
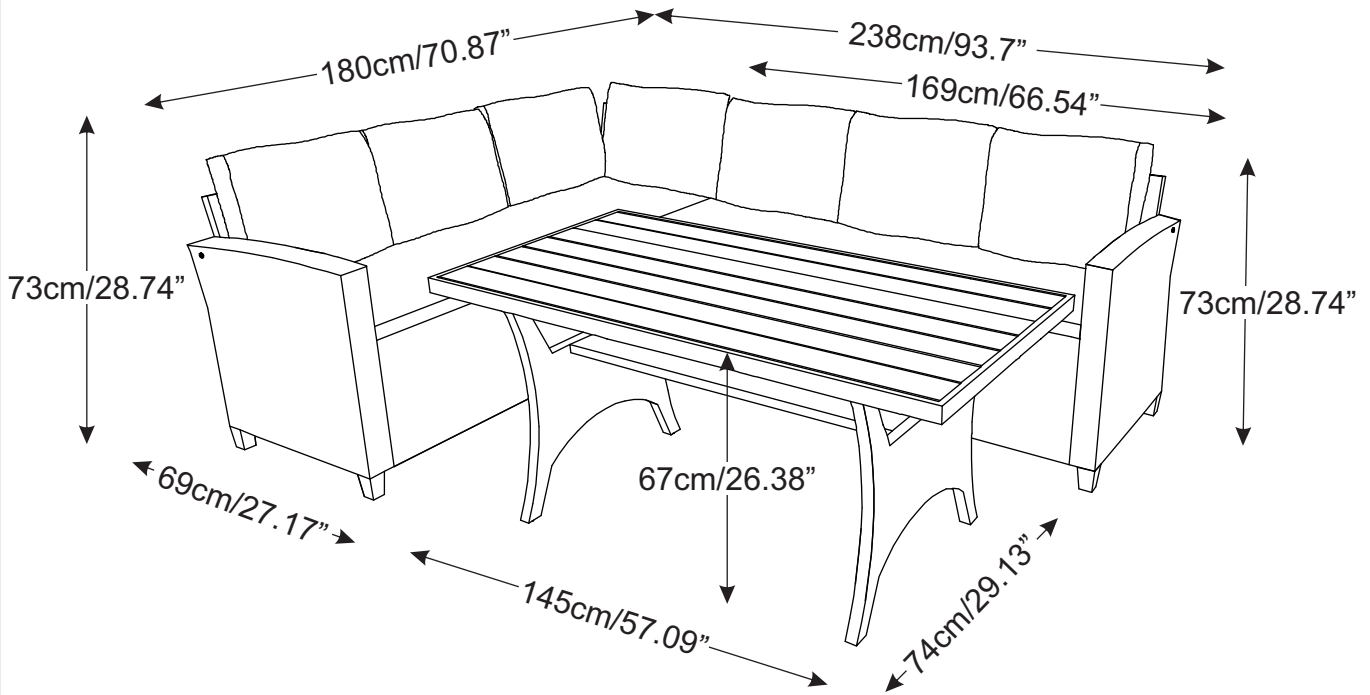

NOTICE – These instructions must be saved for future use – Instructions must be followed

AVIS - Ces instructions doivent être sauvegardées Pour utilisation future - Les instructions doivent être suivies

IMPORTANTE, conservar estas instrucciones para futuro uso. Siga estas instrucciones atentamente

WARNING!

Follow the manual thoroughly and keep it for further reference.

Please read the entire manual carefully before starting to assemble and/or using this product.

In order to avoid scratching of the furniture it should be assembled on a soft layer - could be a rug or blanket.

Be cautious of potential finger entrapment hazards when assembling, using, adjusting or disassembling the product due to its moving parts. The furniture must only be used by children under adult supervision.

Plastic bags, plastic film and small parts can be dangerous!

To avoid danger and risk of suffocation keep away from babies and children!

The furniture and covers may smell after unpacking. The odor is harmless and will disappear after a few days, or even faster with good ventilation.

Before use make sure the furniture is firmly positioned on a stable, hard surface to prevent tipping over.

This outdoor furniture is tested according to European standard EN 581 and is intended for domestic use only.

Seating is tested to a maximum weight of 110 kgs per person.

Sitting or standing on tables is not permitted.

AVERTISSEMENT !

Suivez scrupuleusement le manuel et conservez-le pour une consultation ultérieure.

Lisez attentivement l'intégralité du manuel avant de commencer à assembler et/ou à utiliser ce produit.

Pour éviter de rayer les meubles, il doit être assemblé sur une surface souple, par exemple un tapis ou une couverture.

Faites attention aux risques de coincement des doigts dus aux parties mobiles lorsque vous assemblez, utilisez, réglez ou démontez le produit. Les meubles peuvent être utilisés par des enfants uniquement sous la surveillance d'un adulte.

Les sacs en plastique, le film plastique et les petites pièces peuvent être dangereux !

Pour éviter tout danger et risque d'étouffement, tenez-les hors de portée des bébés et des enfants !

Les meubles et les housses peuvent dégager une odeur après le déballage. L'odeur est inoffensive et disparaîtra après quelques jours, voire plus rapidement avec une bonne ventilation.

Avant utilisation, assurez-vous que les meubles sont fermement posés sur une surface stable et dure pour éviter tout basculement.

Ce mobilier d'extérieur a été testé selon la norme européenne EN 581. Il est destiné à un usage domestique uniquement.

Les sièges sont testés avec un poids maximum de 110 kg par personne.

Il est interdit de s'asseoir ou de se tenir debout sur les tables.

¡ADVERTENCIA!

Siga las instrucciones del manual y guárdelo como referencia.

Lea atentamente el manual completo antes de comenzar a ensamblar y/o usar este producto.

Para evitar raya los muebles, debe montarlos sobre una superficie suave, como una alfombra o una manta.

Tenga cuidado con los posibles peligros de atrapamiento de los dedos al ensamblar, usar, ajustar o desensamblar el producto debido a sus partes móviles. Los niños solo pueden utilizar estos muebles bajo supervisión de un adulto.

¡Las bolsas de plástico, la película plástica y las piezas pequeñas pueden ser peligrosas!

Para evitar el peligro y el riesgo de asfixia, ¡manténgalos alejados de bebés y niños!

Los muebles y fundas pueden oler después de desembalarlos. El olor es inofensivo y desaparecerá después de unos días, o incluso antes si cuenta con una buena ventilación.

Antes de su uso, asegúrese de que los muebles estén firmemente colocados sobre una superficie estable y dura para evitar que se vuelquen.

Este mueble de exterior está probado según la norma europea EN 581 y está destinado solo para uso doméstico.

Los asientos se prueban con un peso máximo de 110 kg por persona.

No está permitido sentarse o estar de pie sobre las mesas.

CHECK LIST
 LISTE DE CONTROLE
 LISTADO DE CONTROL

Réf./No.	Réf./Art.	Qty./Stck./Quantité	Size / Maß / Dimension (mm)	Qty./Stck./Quantité	Box/Colli	✓
1	232431	1	645x575x90		1	
2	232432	1	645x575x90		1	
3	232433	1	670x610x70		1	
4	232434	1	1610x675x70		2	
5	232435	1	1610x675x70		2	
6	232436	1	1610x580x330		1	
7	232437	1	1610x580x330		1	
8	232438	2	1600x580x60		1	
9	232439	7	510x400x160		1	
10	232440	1	1450x740x45		3	
11	232441	2	670x630x110		2	
12	232442	1	970x255x20		2	
13	232443	2	1545x510x50		1	
14	232444	2	1600x590x25		2	
15	232445	2	1600x580x300		1	
16	232446	1	Hardware box		1	

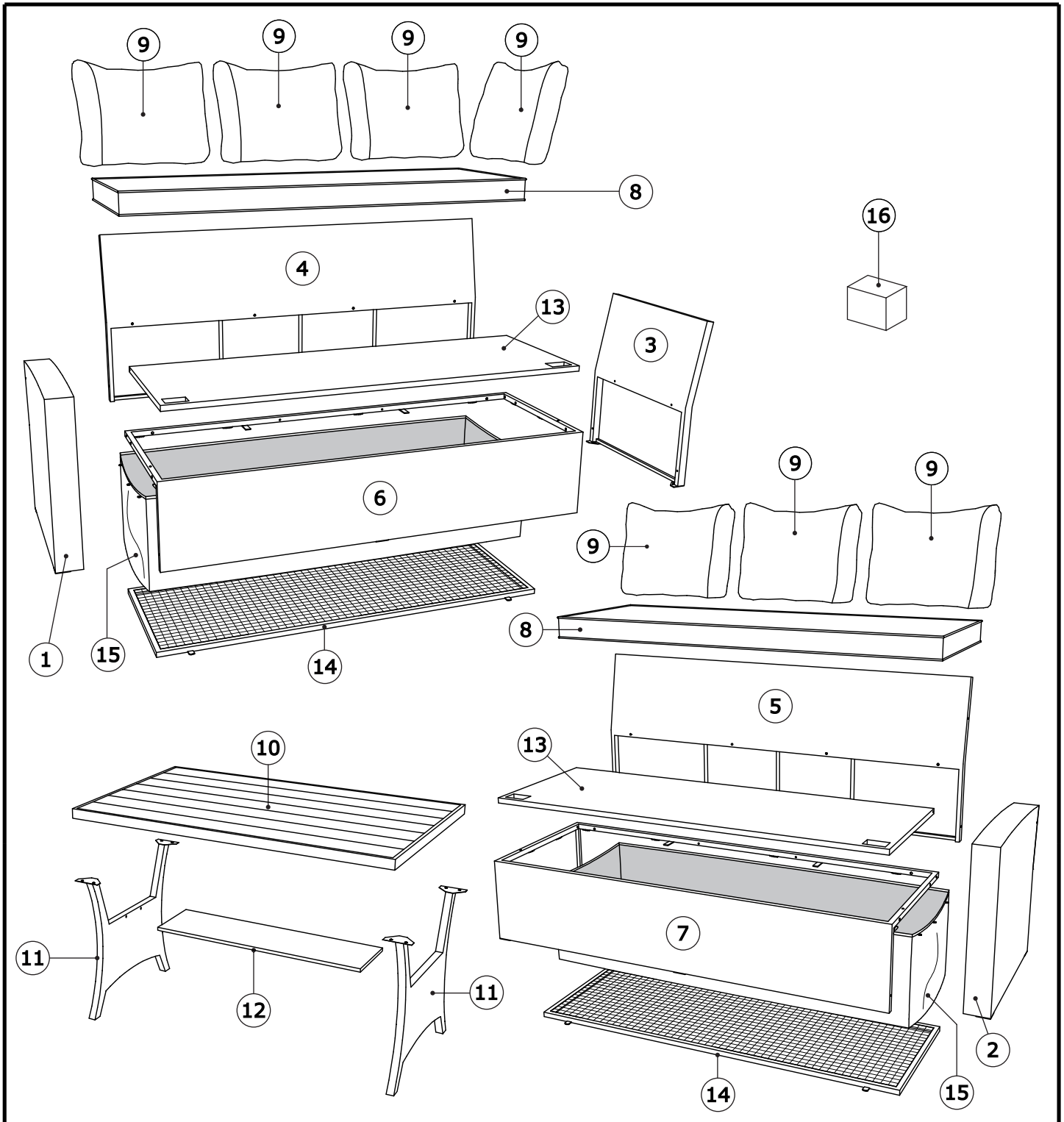

CHECK LIST - LISTE DE CONTROLE - LISTADO DE CONTROL

Réf./No.	Réf./Art.	Qty./Stck./Quantité	✓
A	232446	25	
B	232446	20	
C	232446	2	
D	232446	35	
E	232447	12	
F	232448	2	
G	232446	8	
H	232446	8	
I	232446	2	
J	232446	12	
K	232449	4	
L	232446	4	
M	232446	1	
N	232446	2	

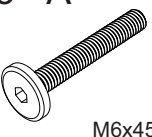
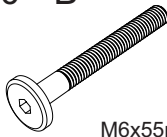
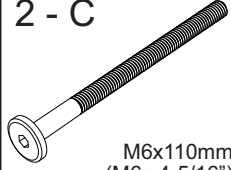
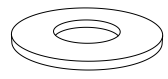
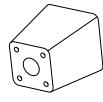
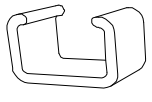
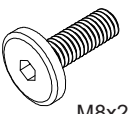
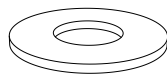
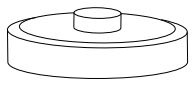
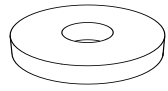
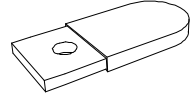
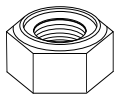
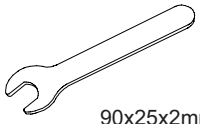
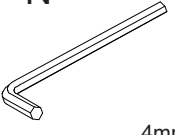
<p>25 - A</p>  <p>M6x45mm (M6x 1-3/4")</p>	<p>20 - B</p>  <p>M6x55mm (M6x 2-3/16")</p>	<p>2 - C</p>  <p>M6x110mm (M6x 4-5/16")</p>	<p>35 - D</p>  <p>M6</p>	<p>12 - E</p>  <p>45x45x65mm (1-3/4x1-3/4x2-1/2")</p>	<p>2 - F</p>  <p>60x40x30mm (2-3/8x1-9/16x1-3/16")</p>
<p>8 - G</p>  <p>M8x20mm (M8x 13/16")</p>	<p>8 - H</p>  <p>M8</p>	<p>2 - I</p>  <p>Ø16x5mm (Ø5/8x3/16")</p>	<p>12 - J</p>  <p>M6</p>	<p>4 - K</p>  <p>45x24x5mm (1-3/4x15/16x3/16")</p>	<p>4 - L</p>  <p>M6</p>
<p>1 - M</p>  <p>90x25x2mm (3-9/16x1x1/16")</p>	<p>2 - N</p>  <p>4mm 5/32"</p>				

Dear Customer.
Below you have the opportunity to measure the
Enclosed Hardware.

Cher Client.
La règle ci jointe vous permet de mesurer la visserie.

Estimado cliente.
aquí podrá medir la tornillería adjunta.

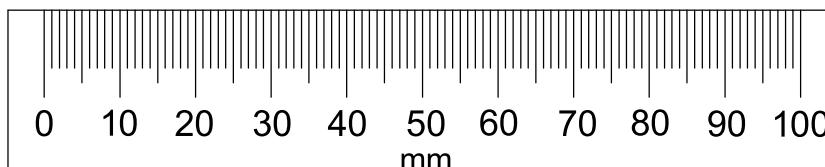

1 A x 4 D x 4 N x 2

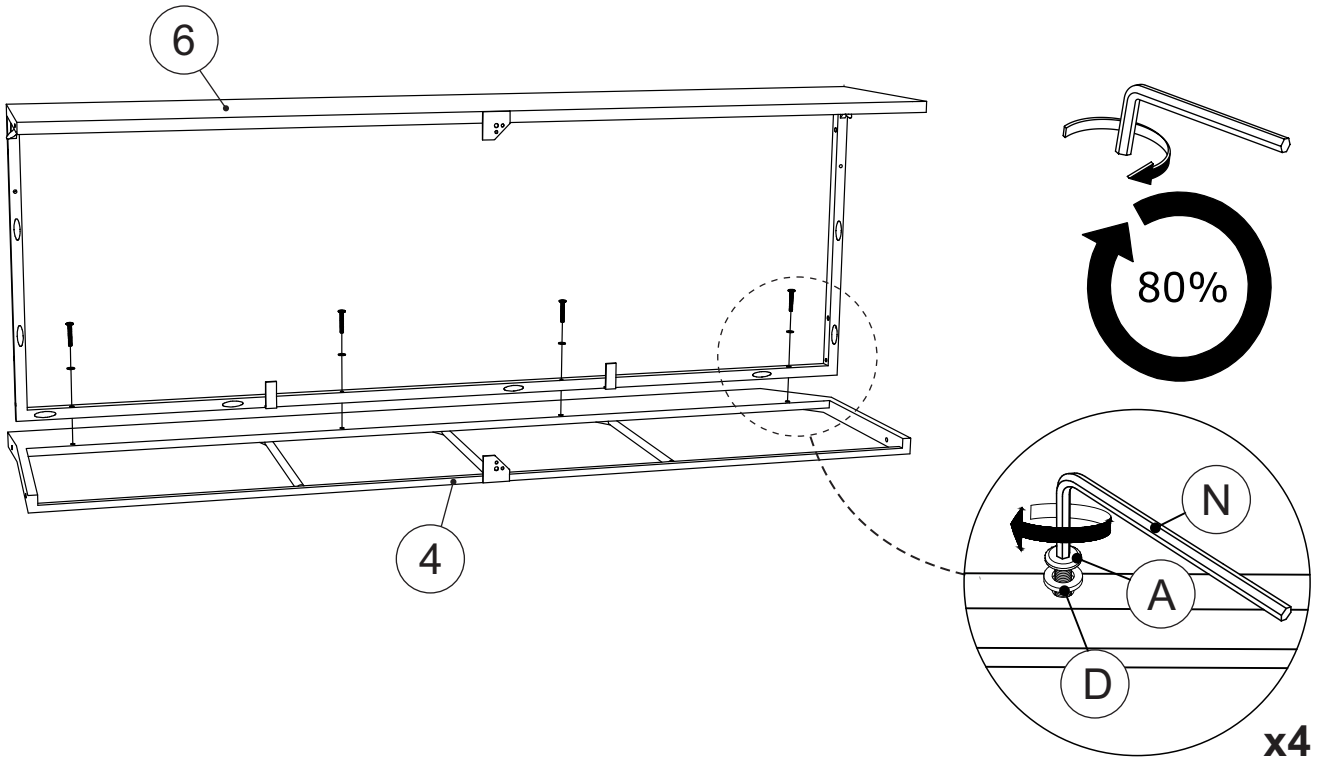

2

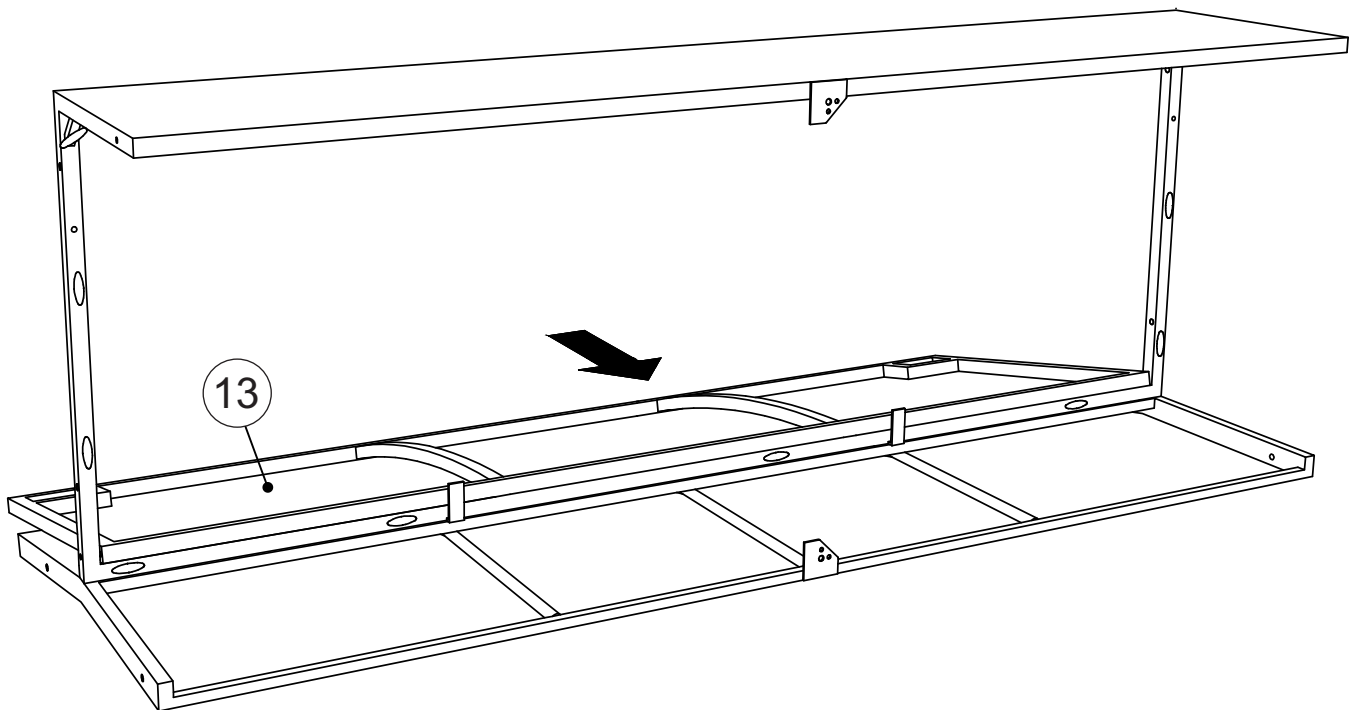

3
B x 2
J x 2
N x 2

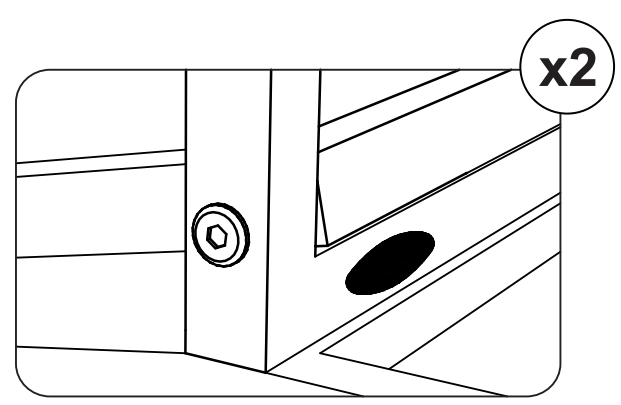
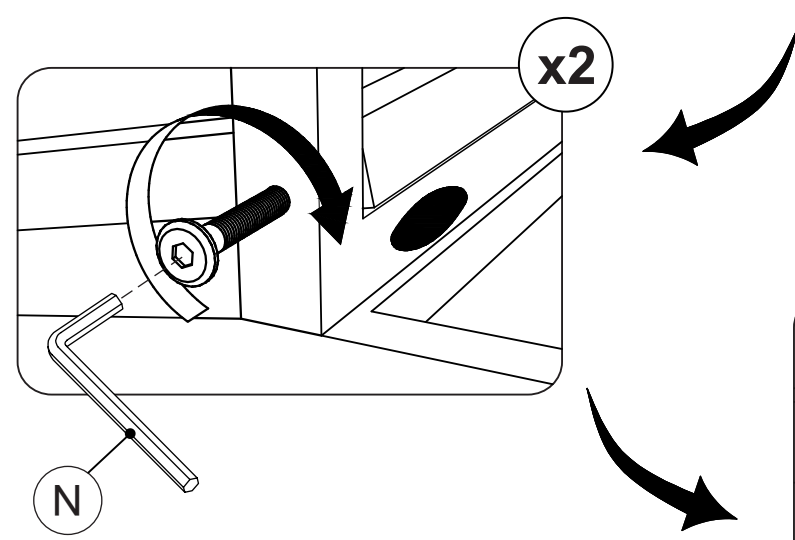
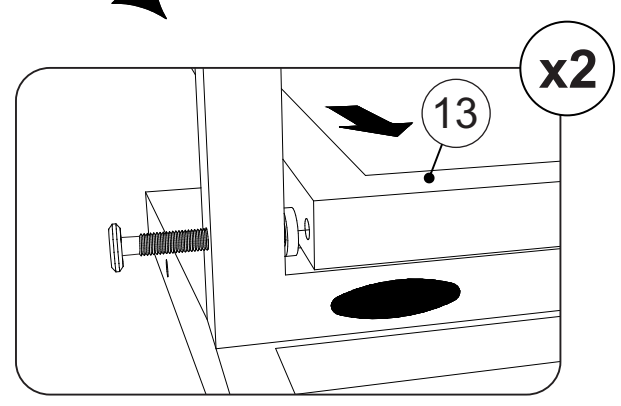
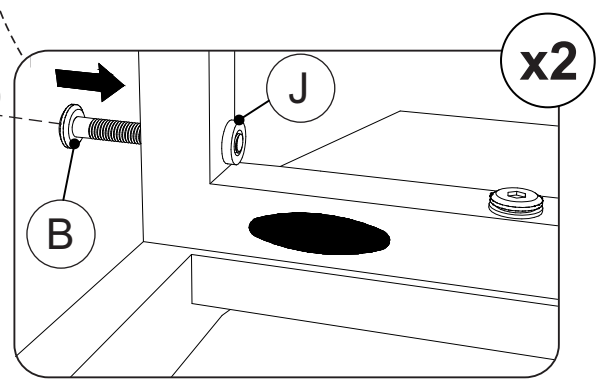
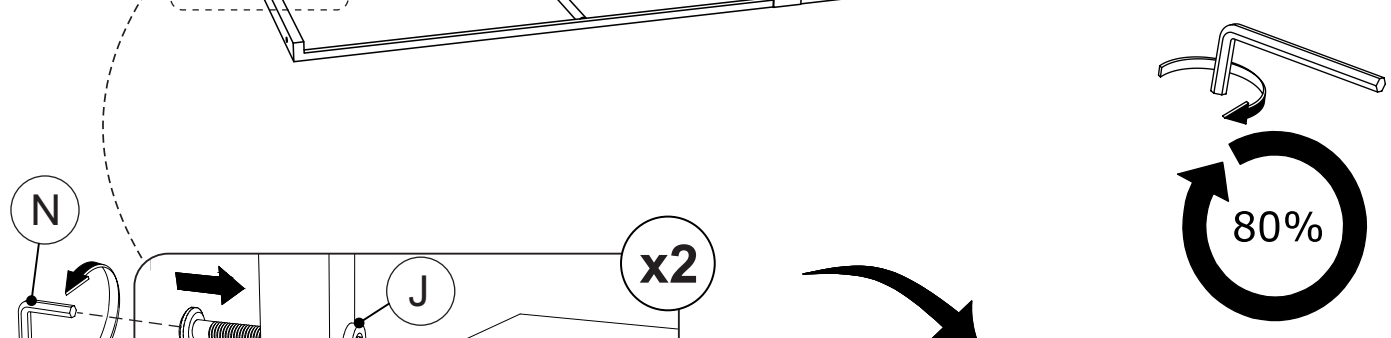
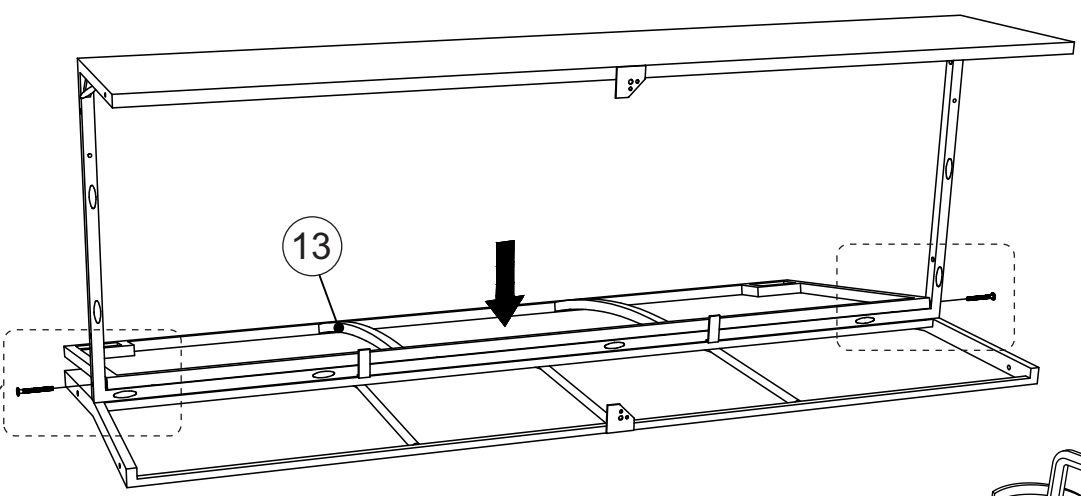
4 C x 1 D x 1 I x 1 N x 1

5 A x 2 D x 2 N x 2

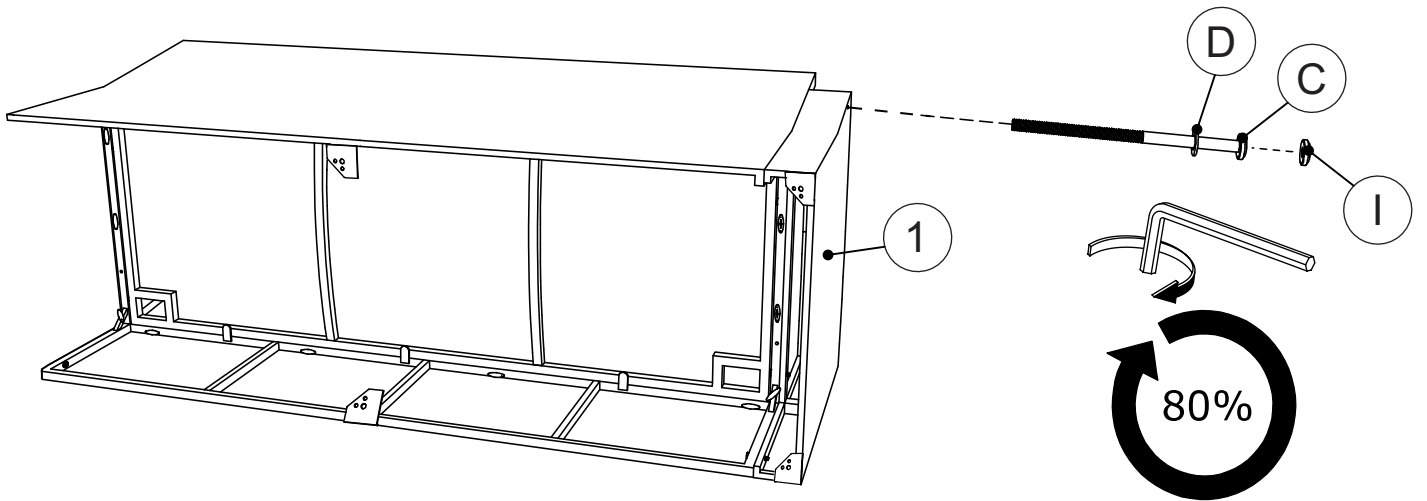
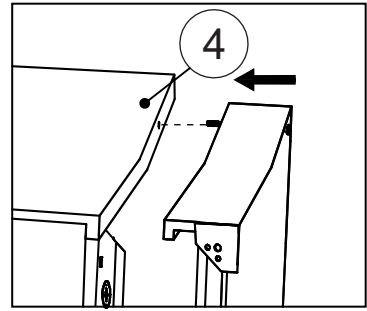
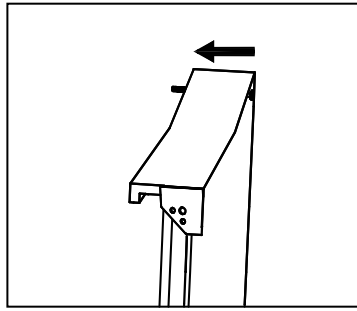
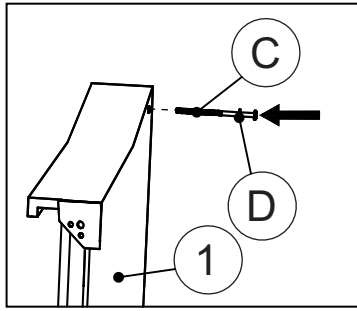
6 A x 2 D x 2 N x 2

7 A x 4 D x 4 N x 2

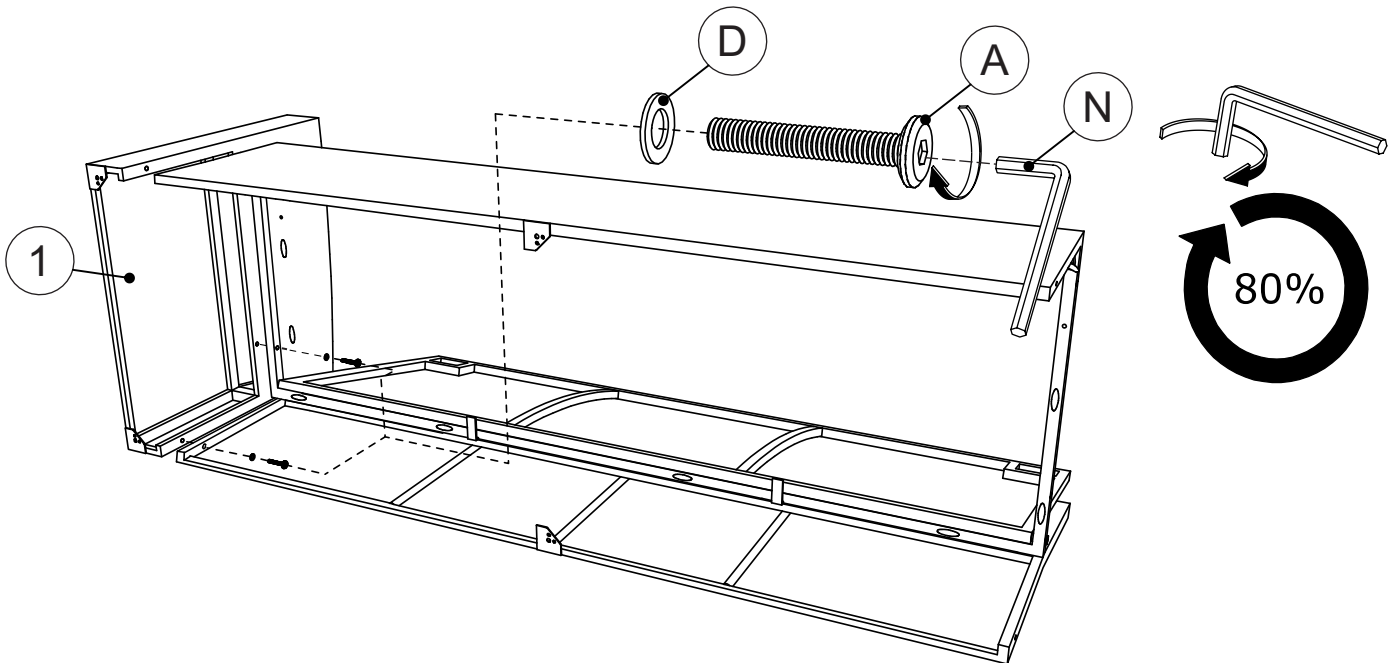
8 B x 6 E x 6 N x 2

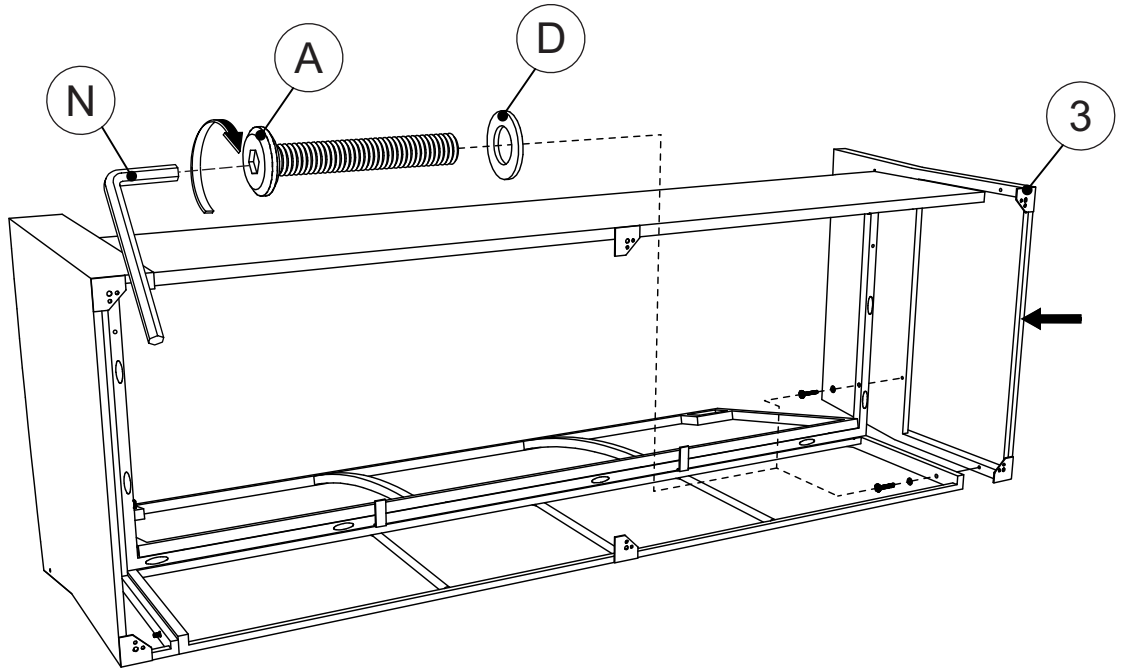
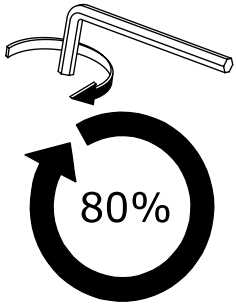
9 N x 2

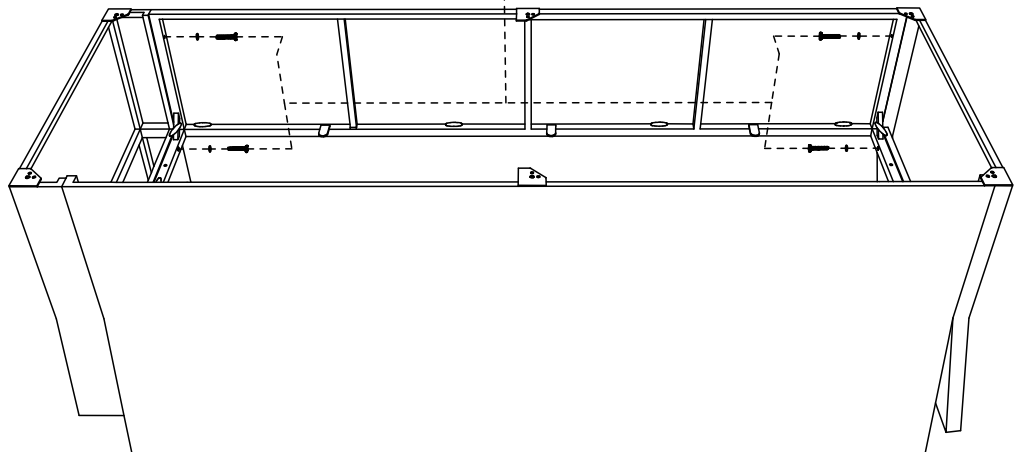
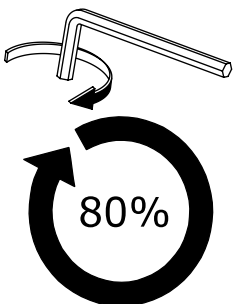
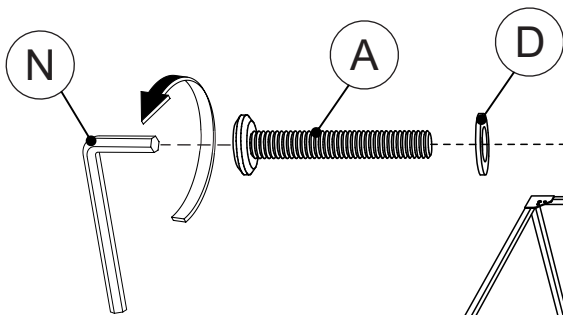
10

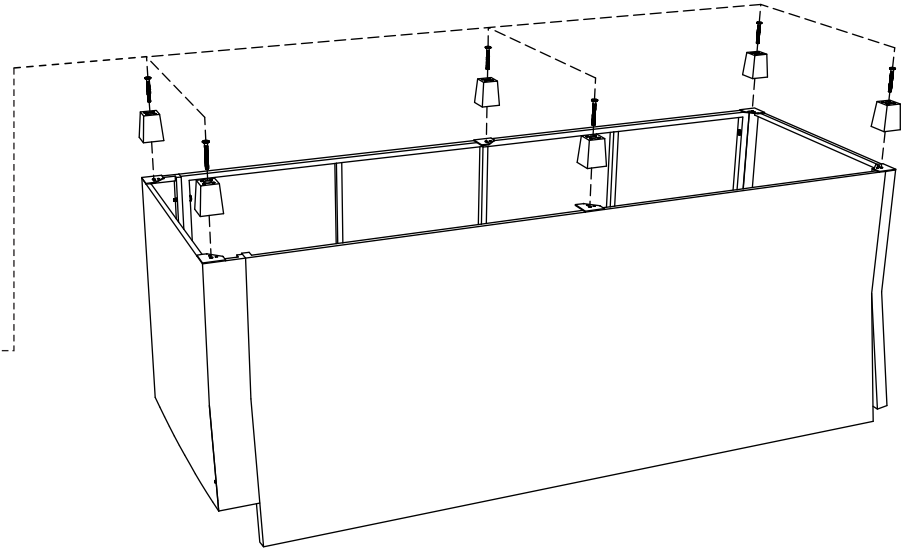
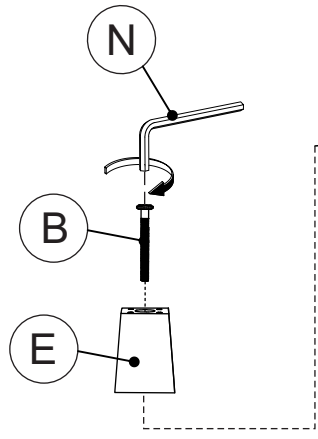
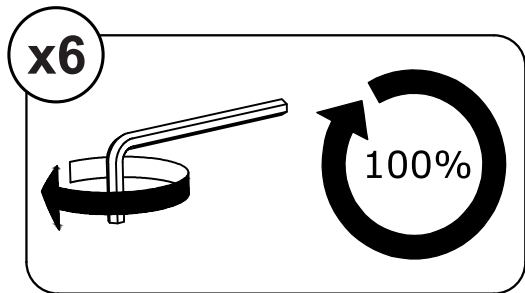

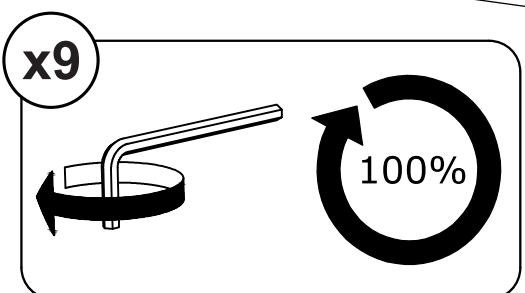
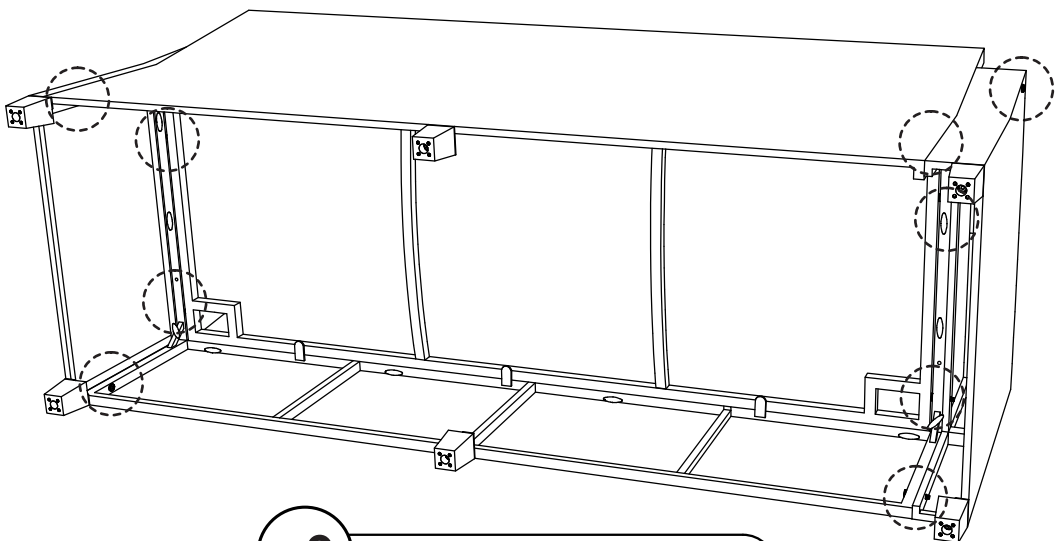
11
B x 2
D x 4
K x 2
J x 4
L x 2
M x 1
N x 2

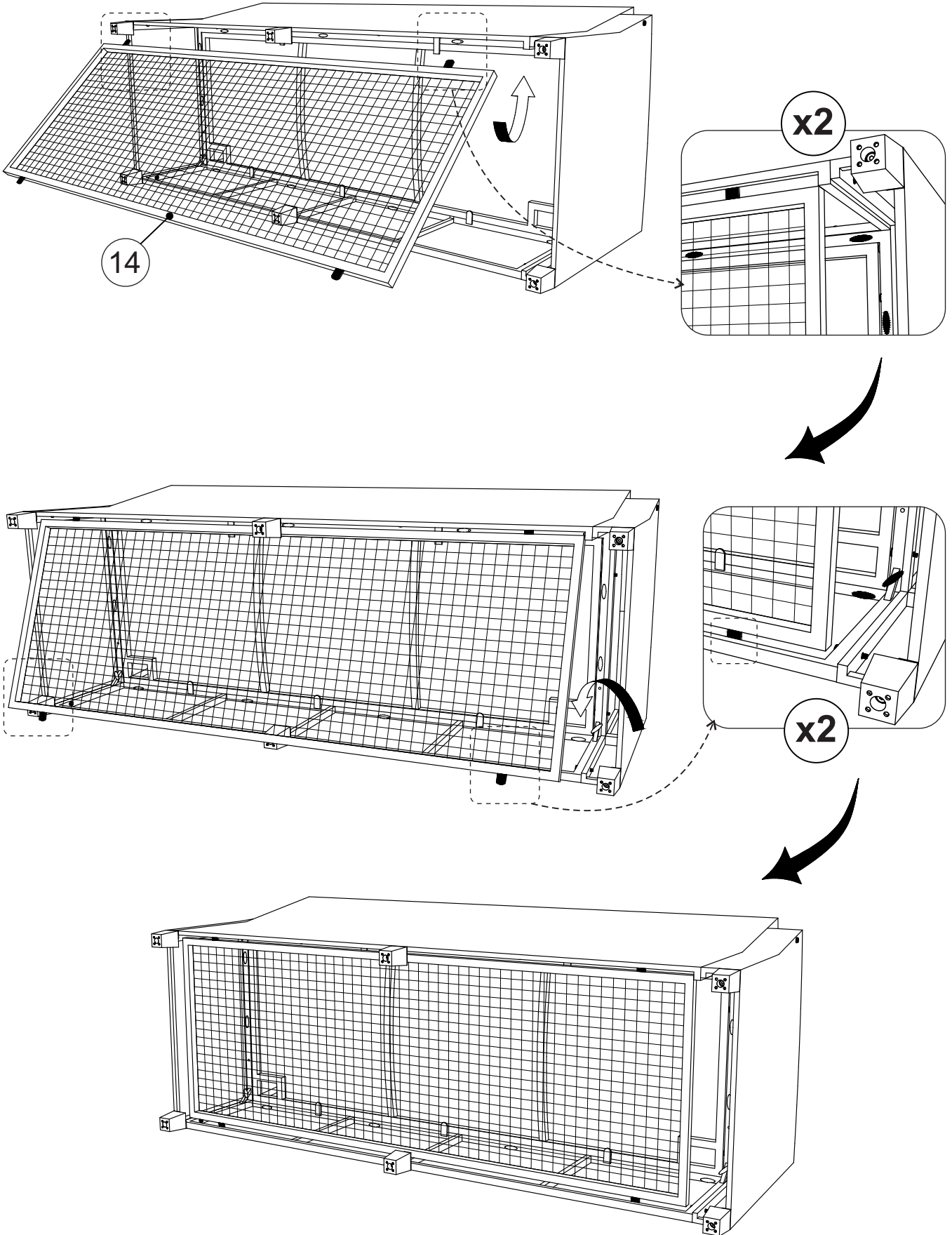
12

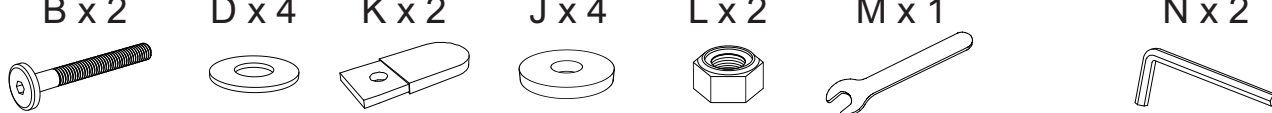
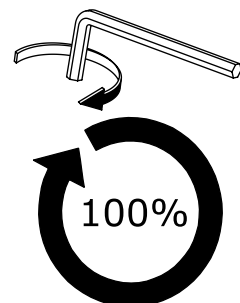
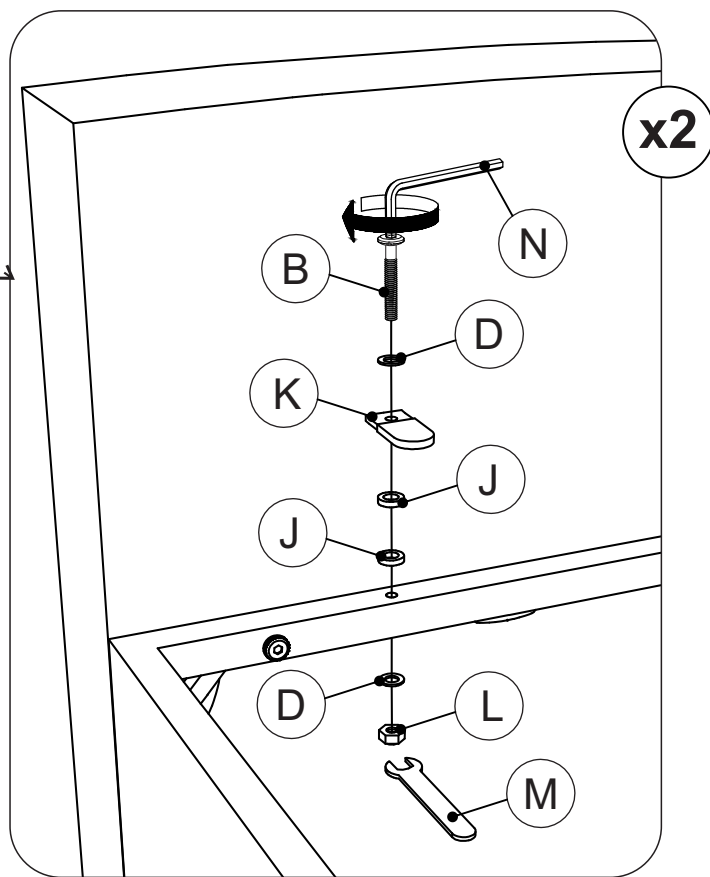
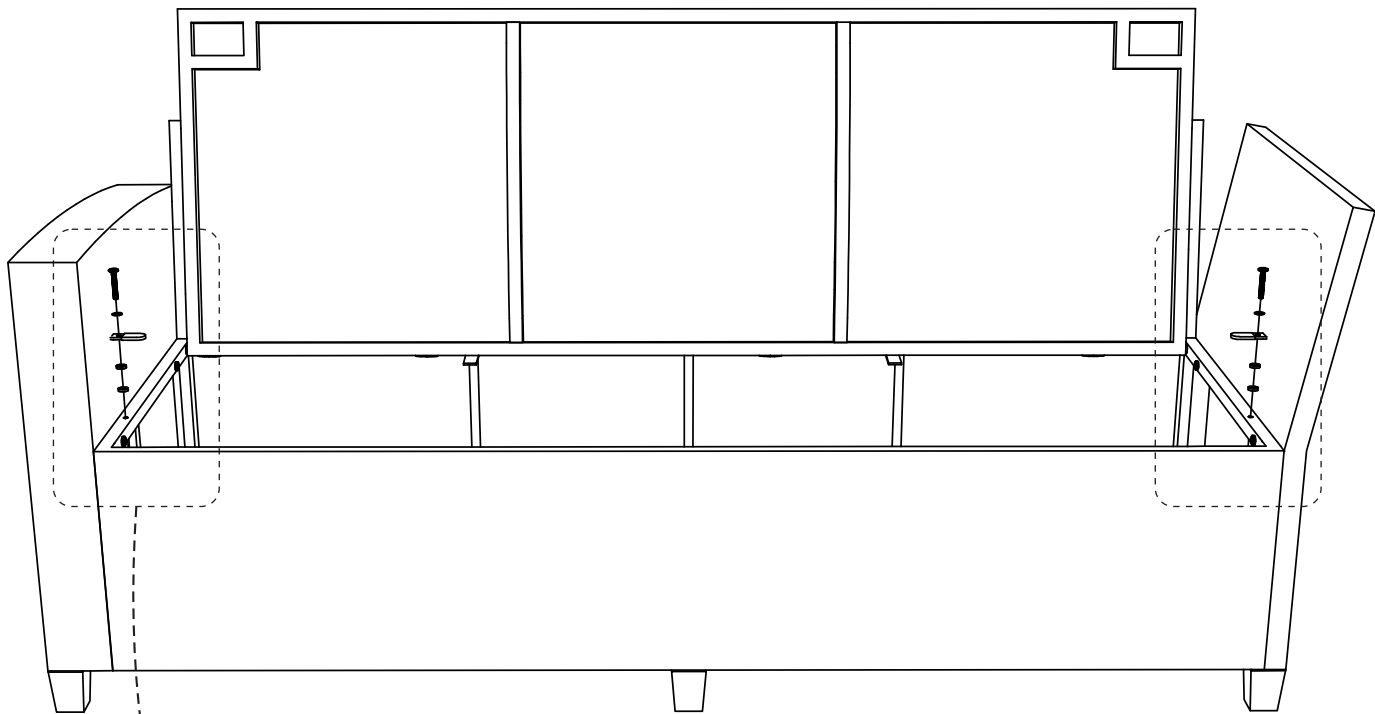

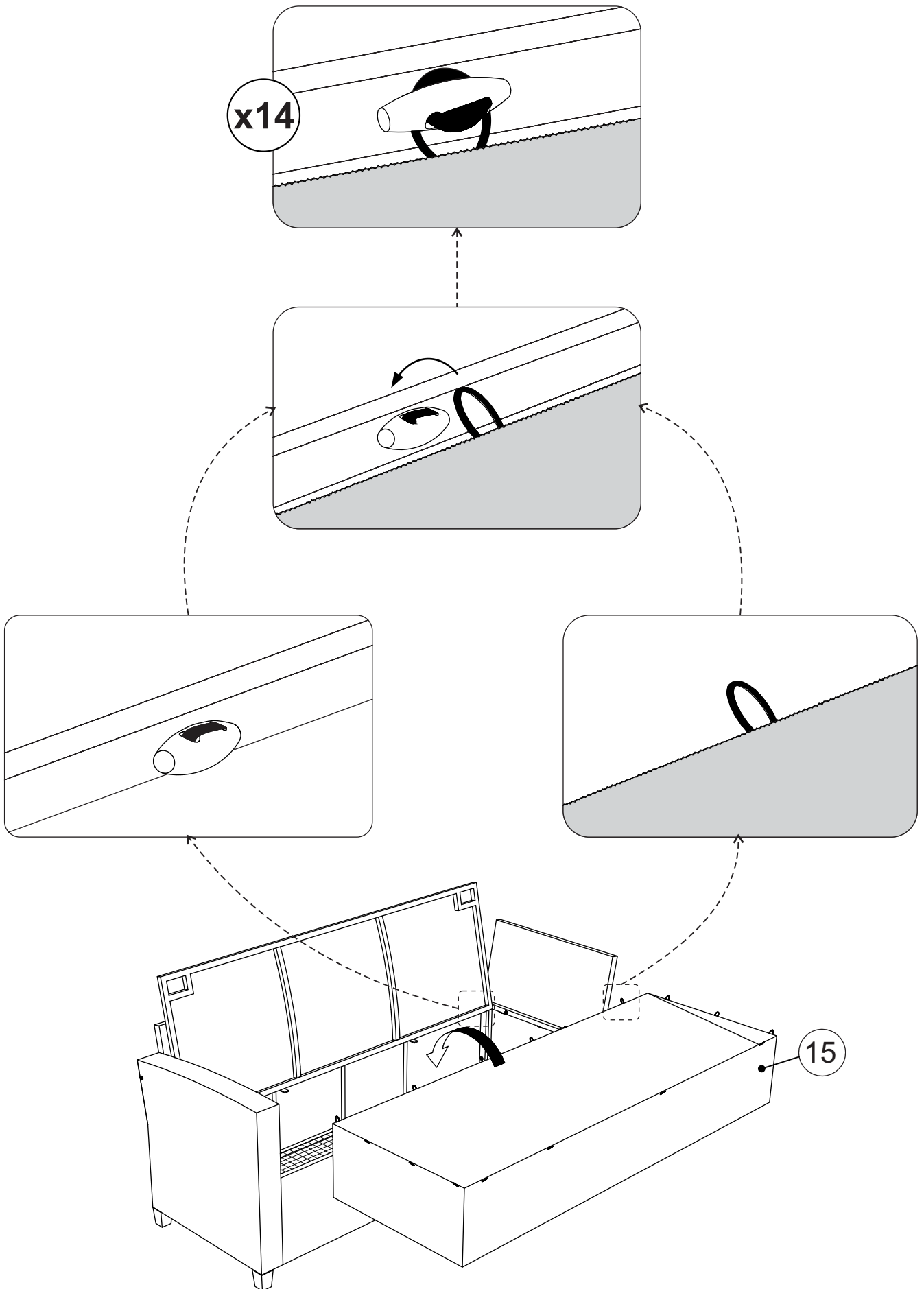
13

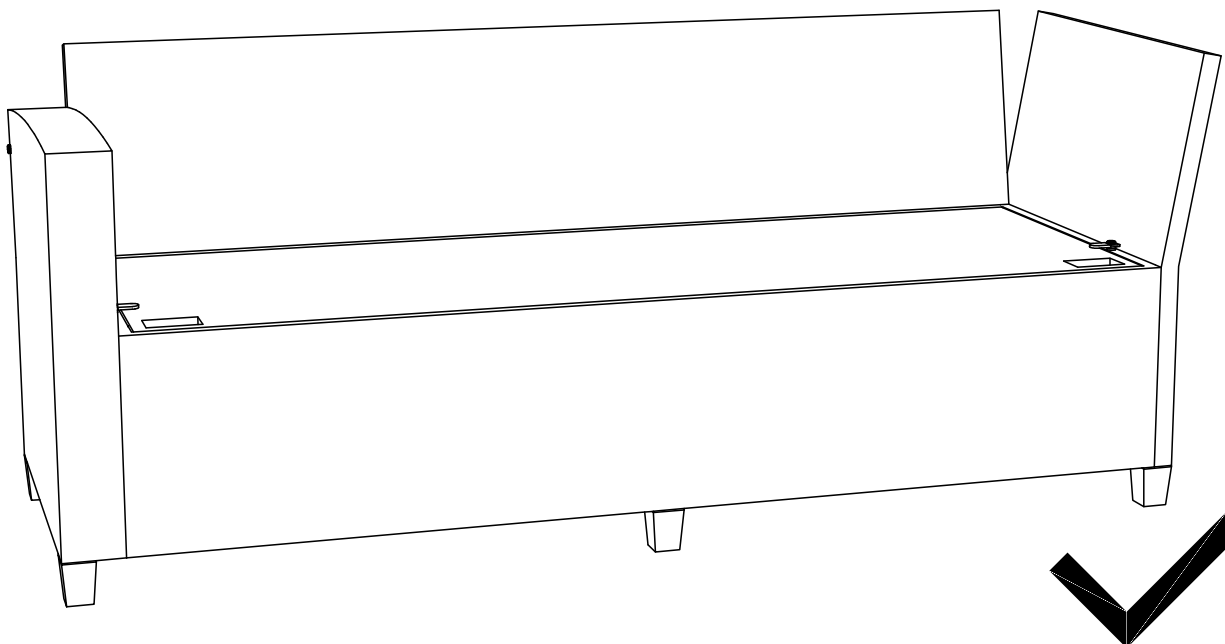
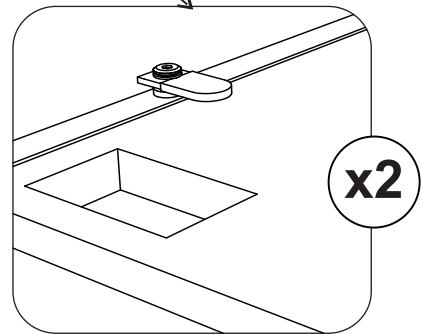
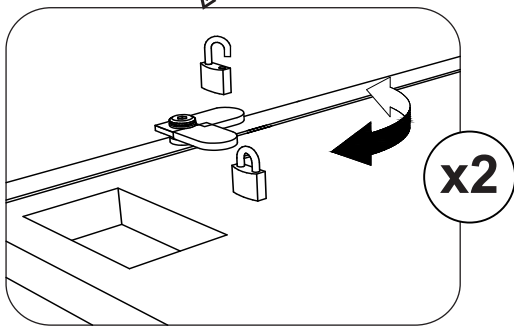
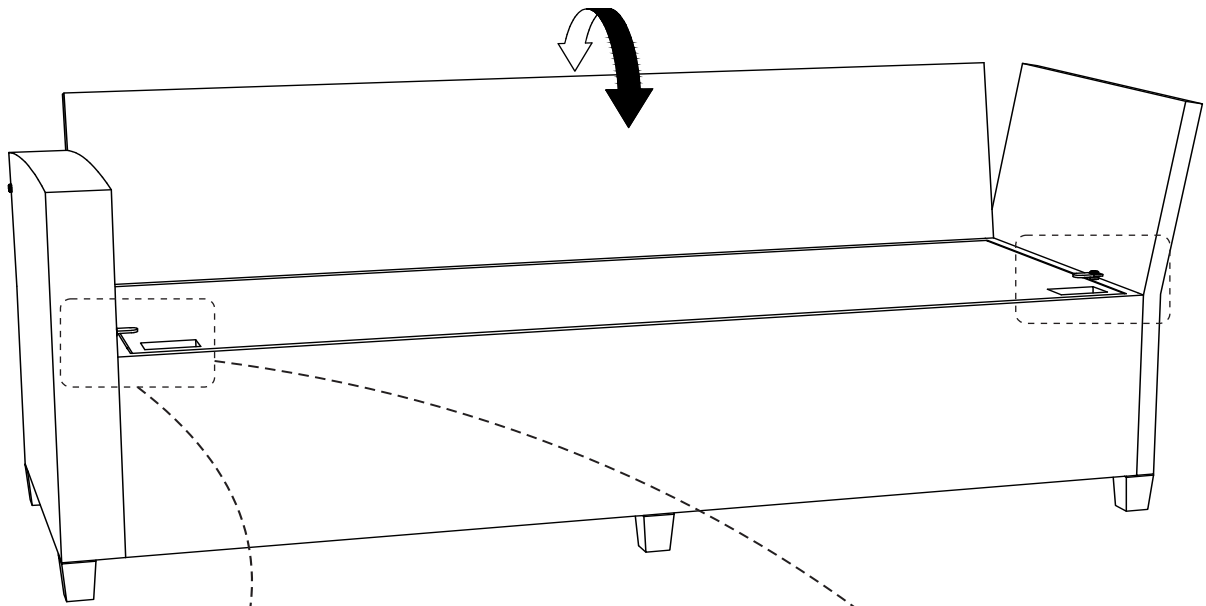

14 A x 5 D x 5 N x 2

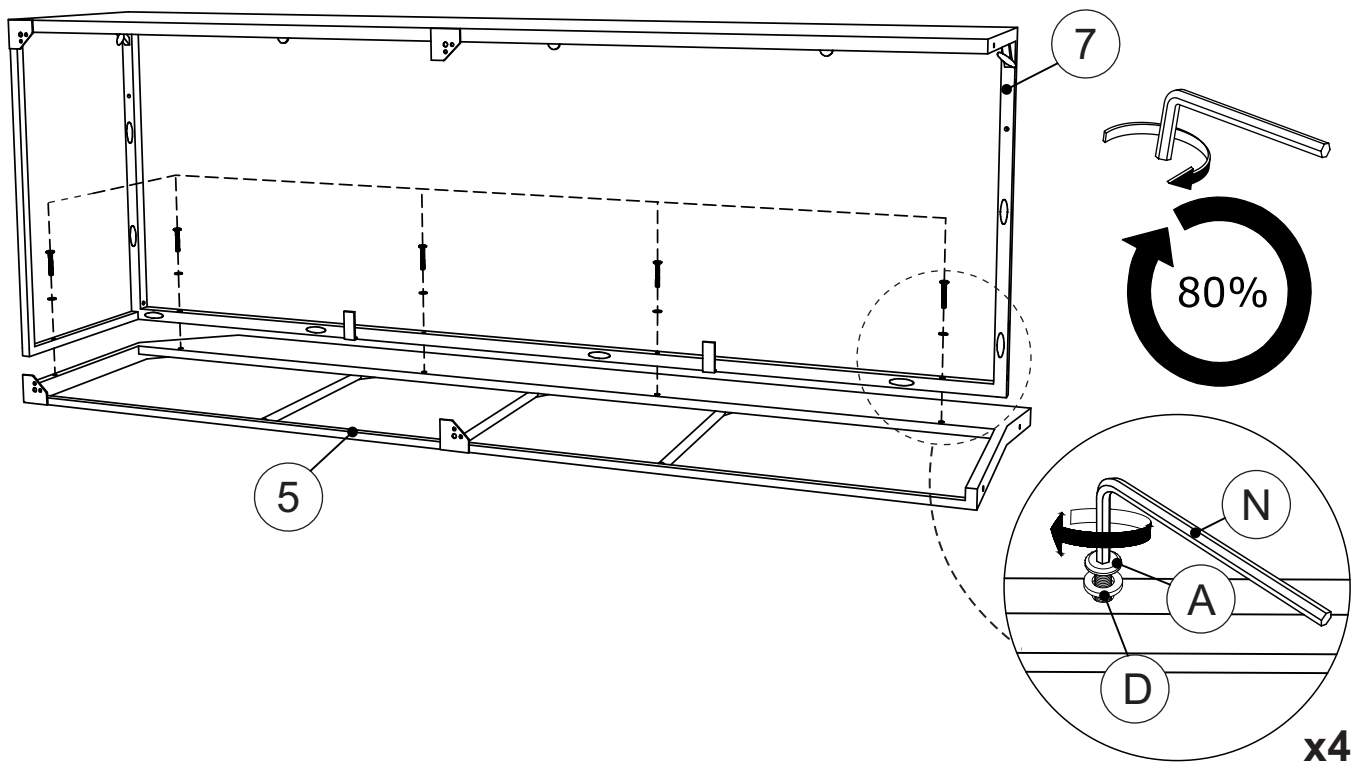
15

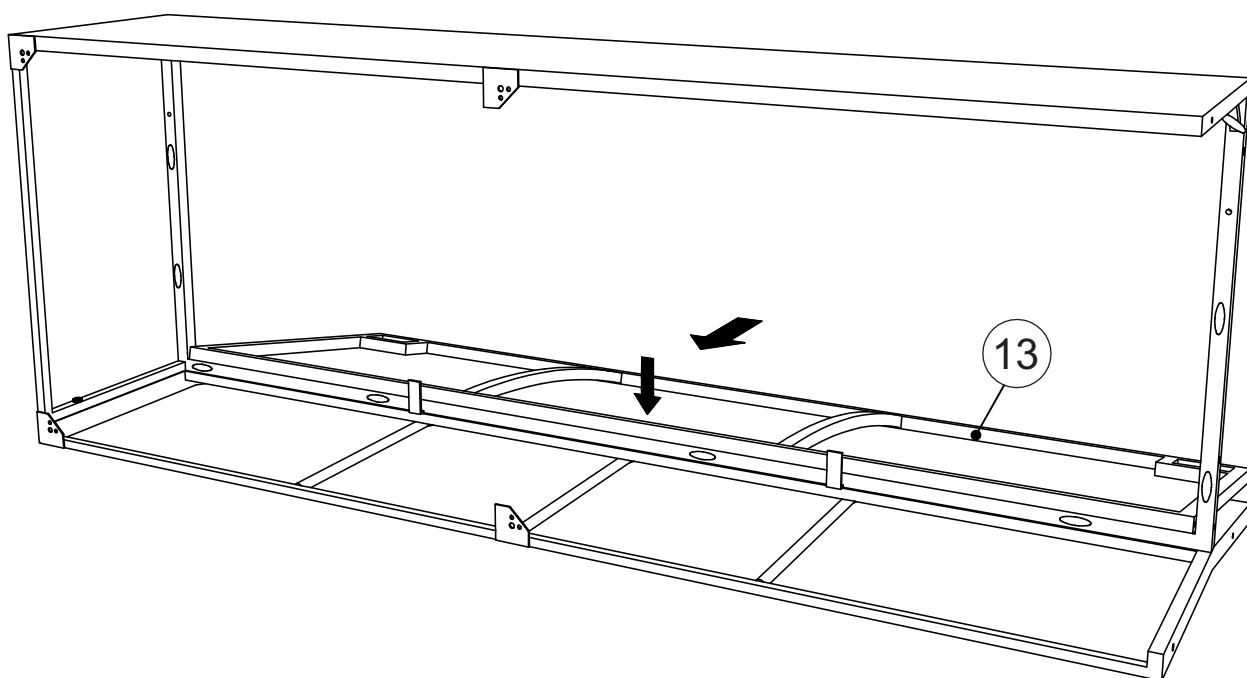

16

B x 2

J x 2

N x 2

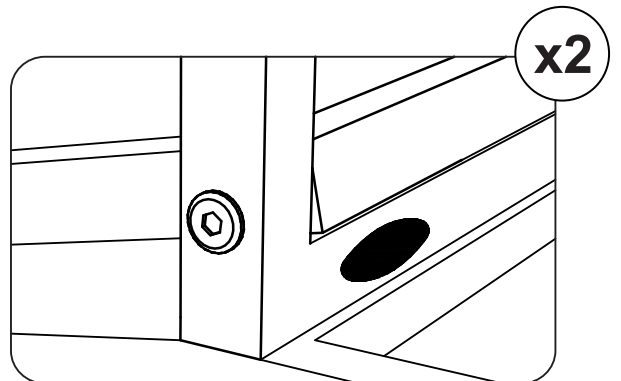
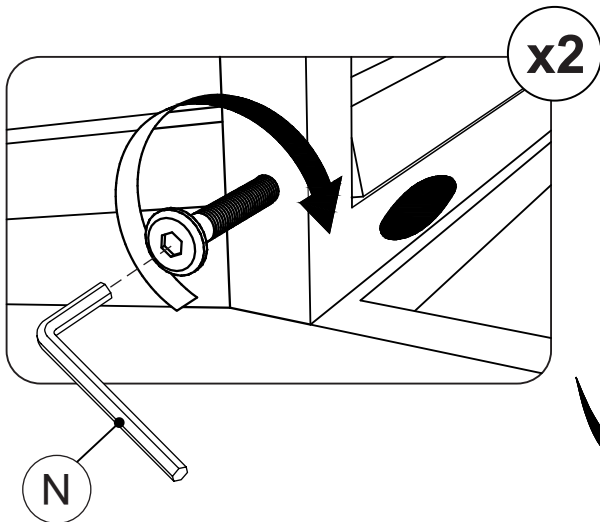
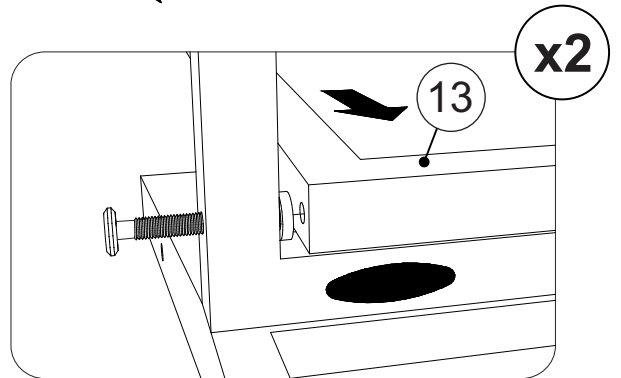
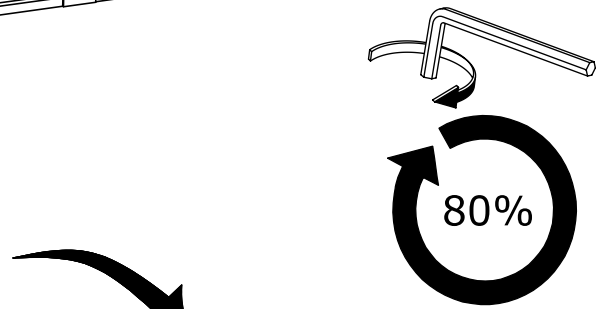
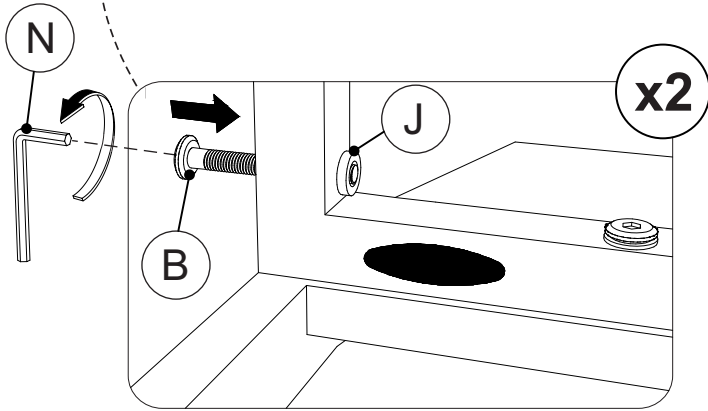
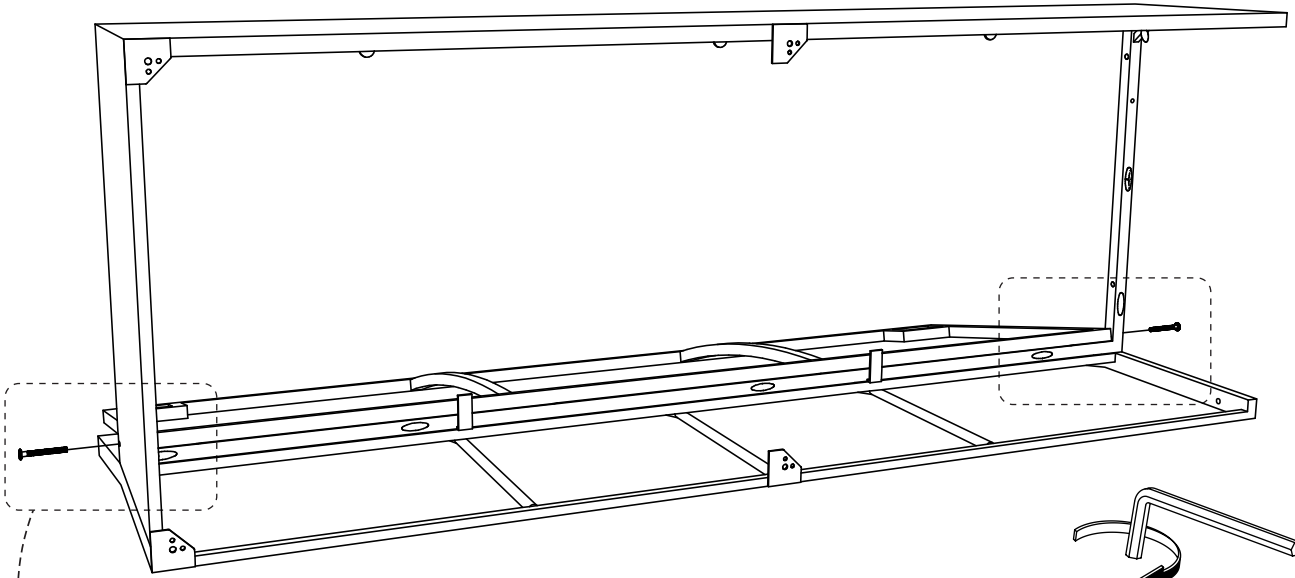
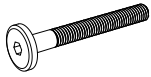

17 C x 1 D x 1 I x 1 N x 1

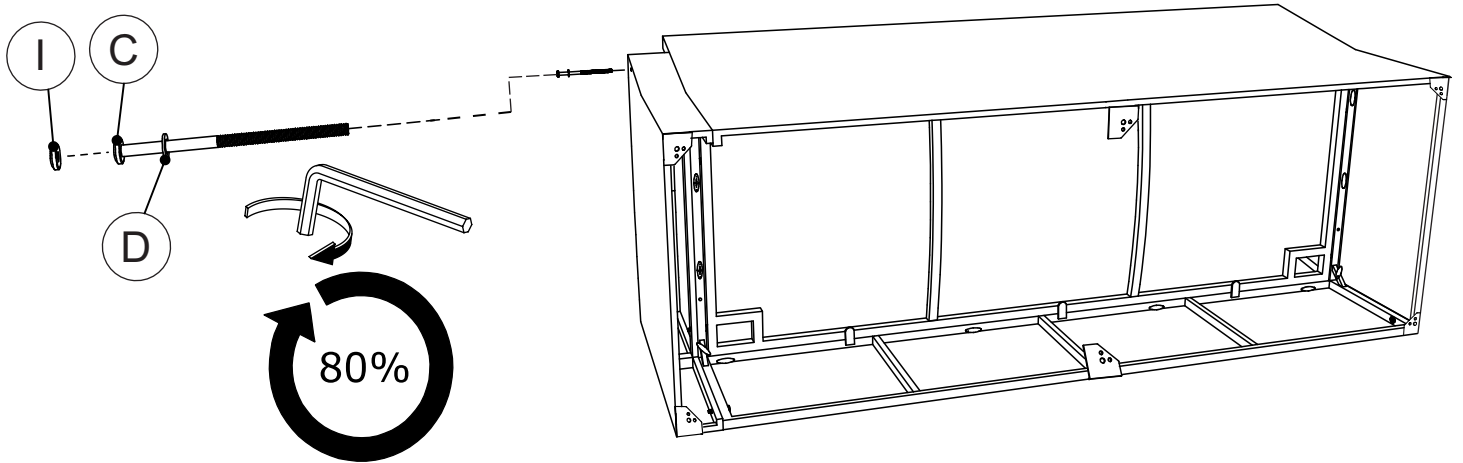
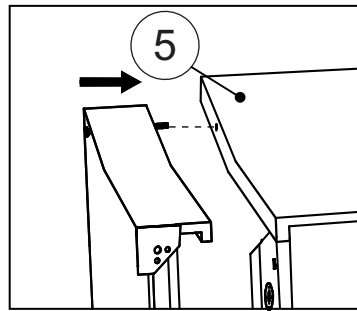
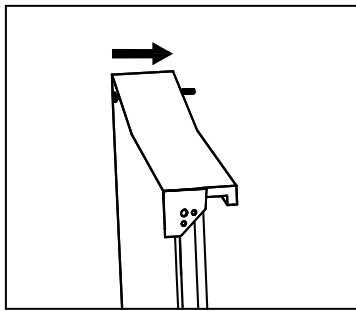
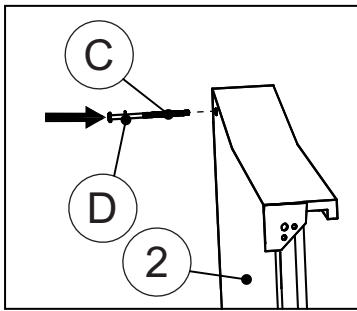
18 A x 2 D x 2 N x 2

19 A x 2 D x 2 N x 2

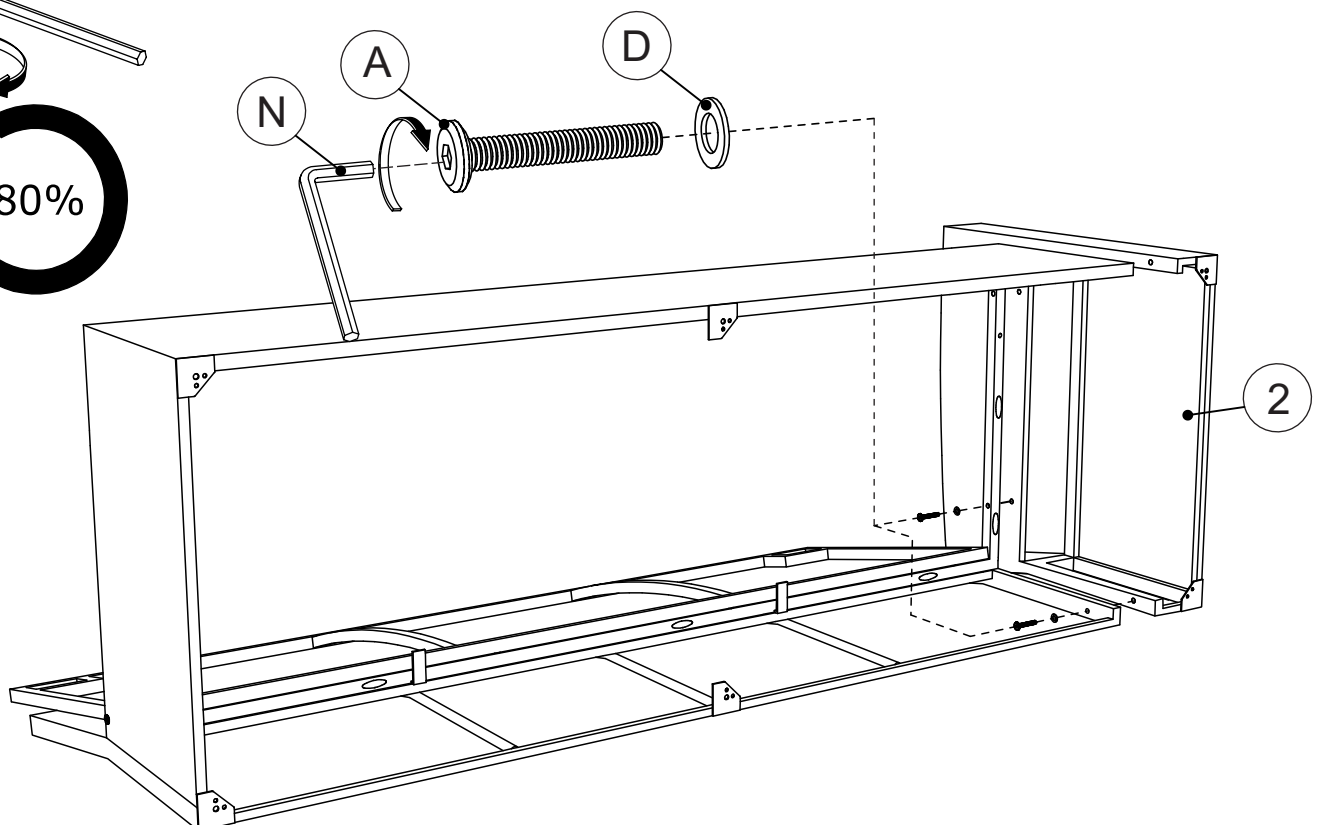
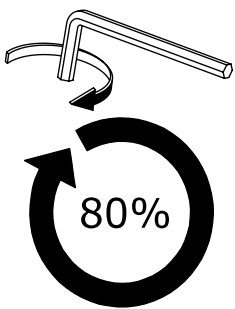

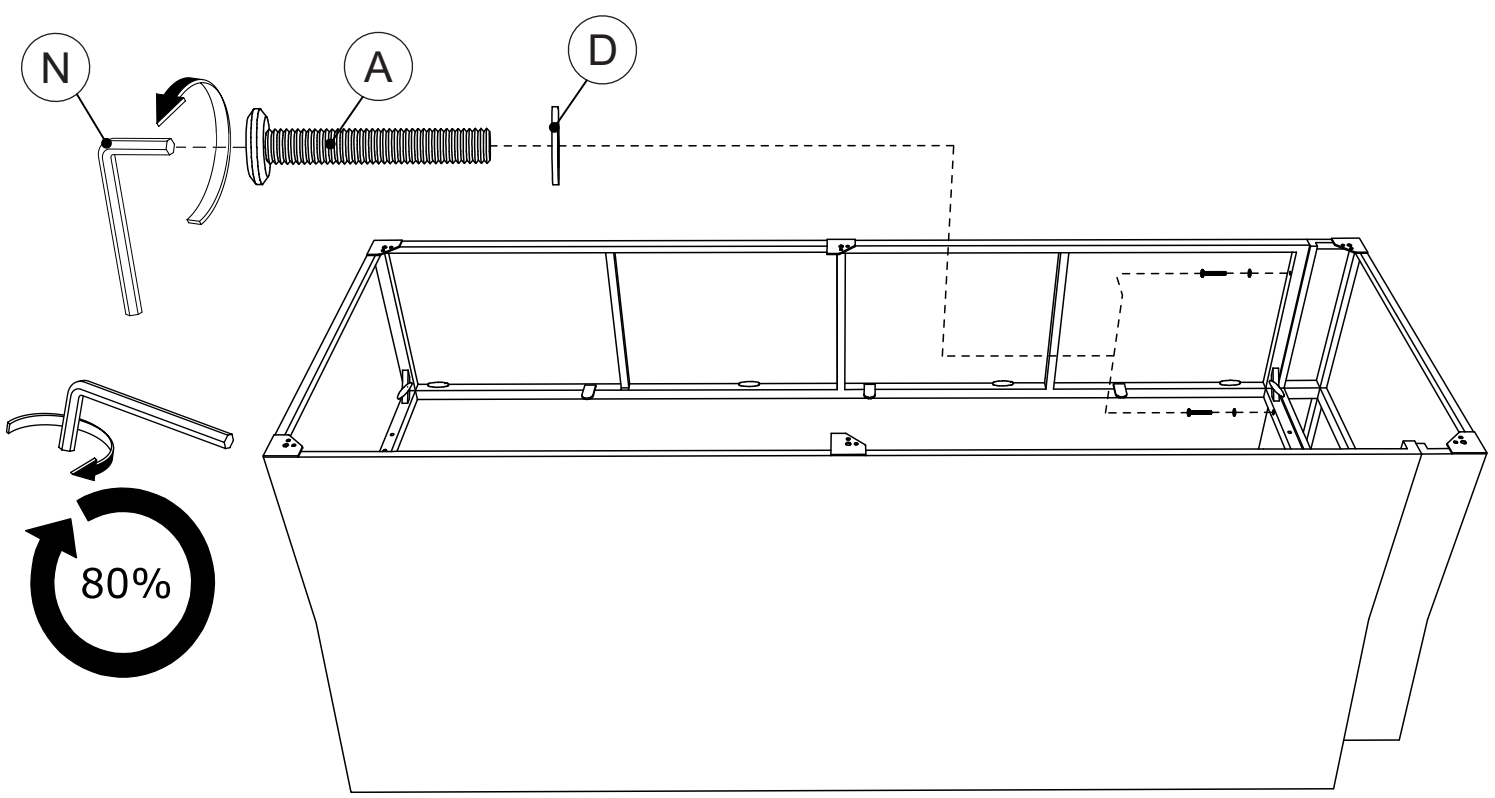

20 B x 6 E x 6 N x 2

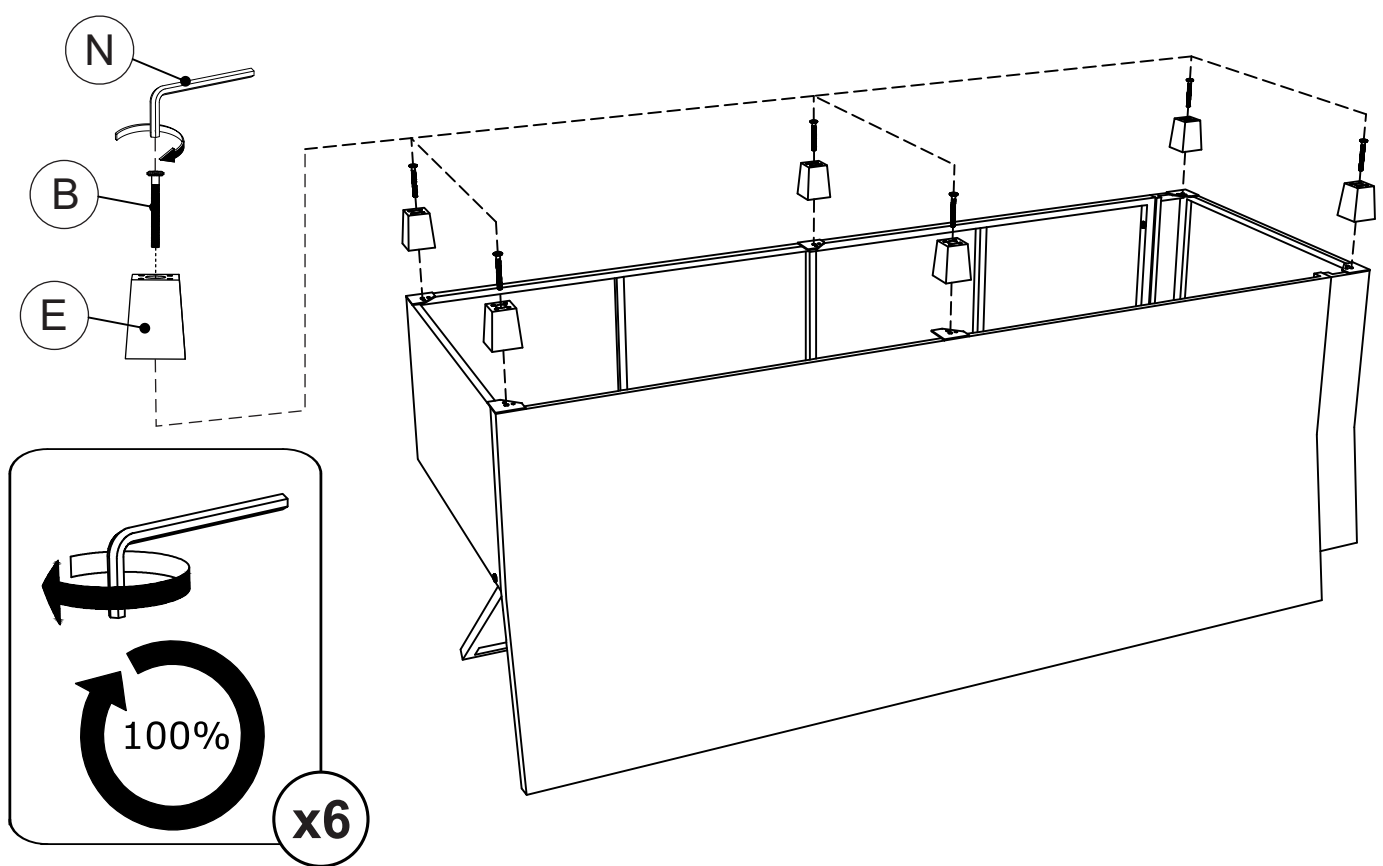

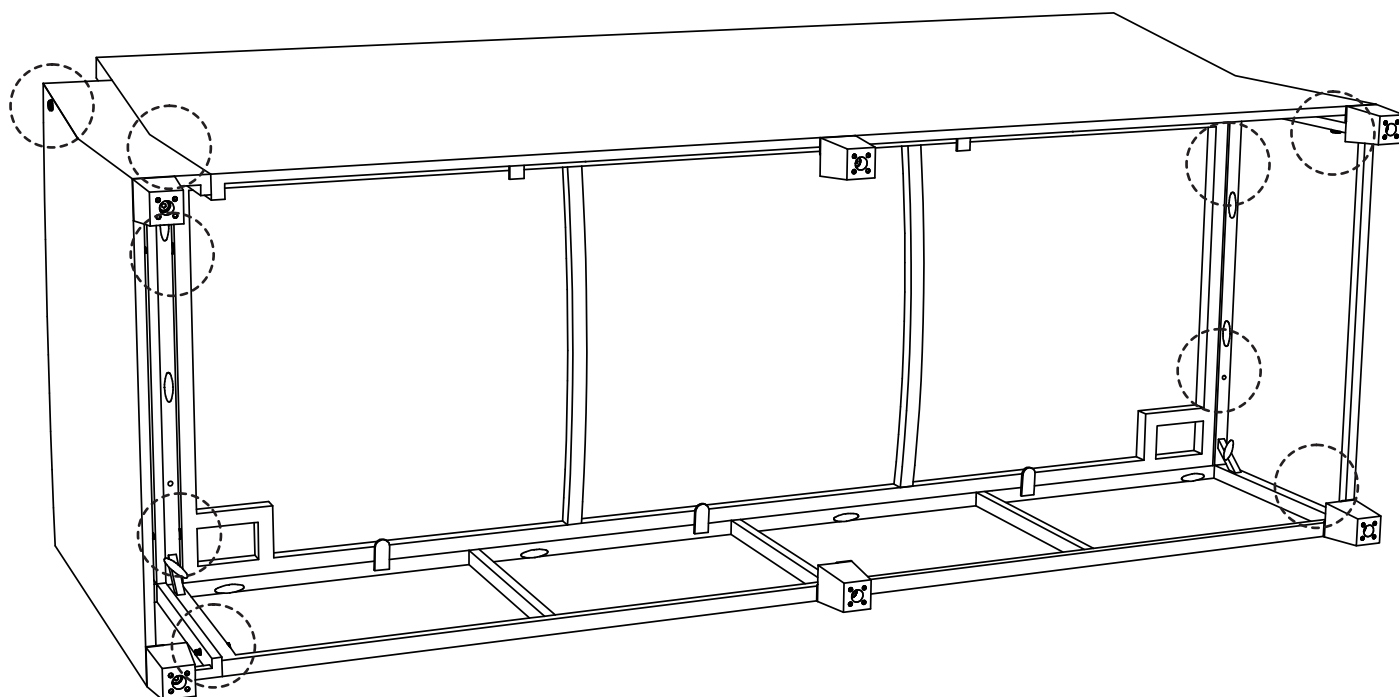
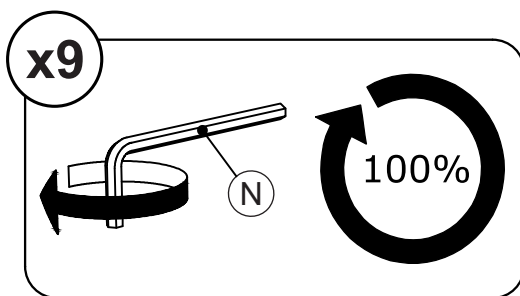

21

N x 2

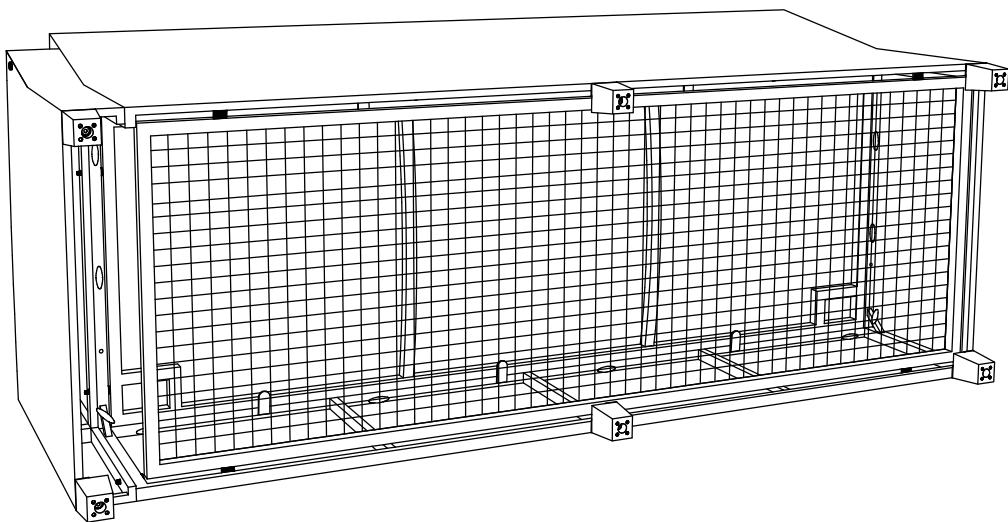
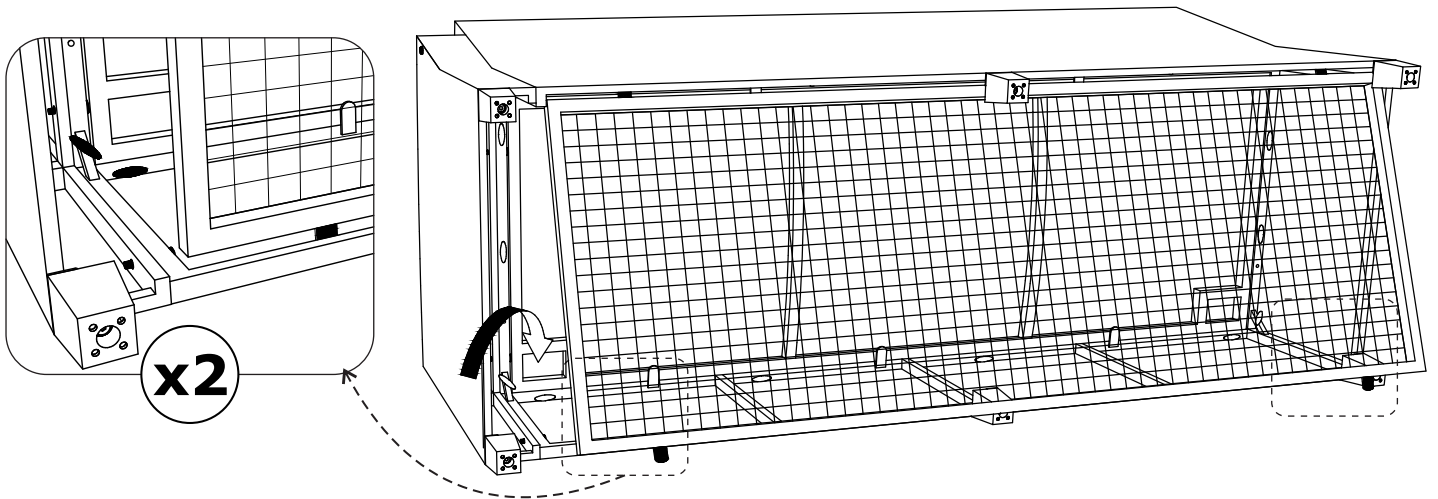
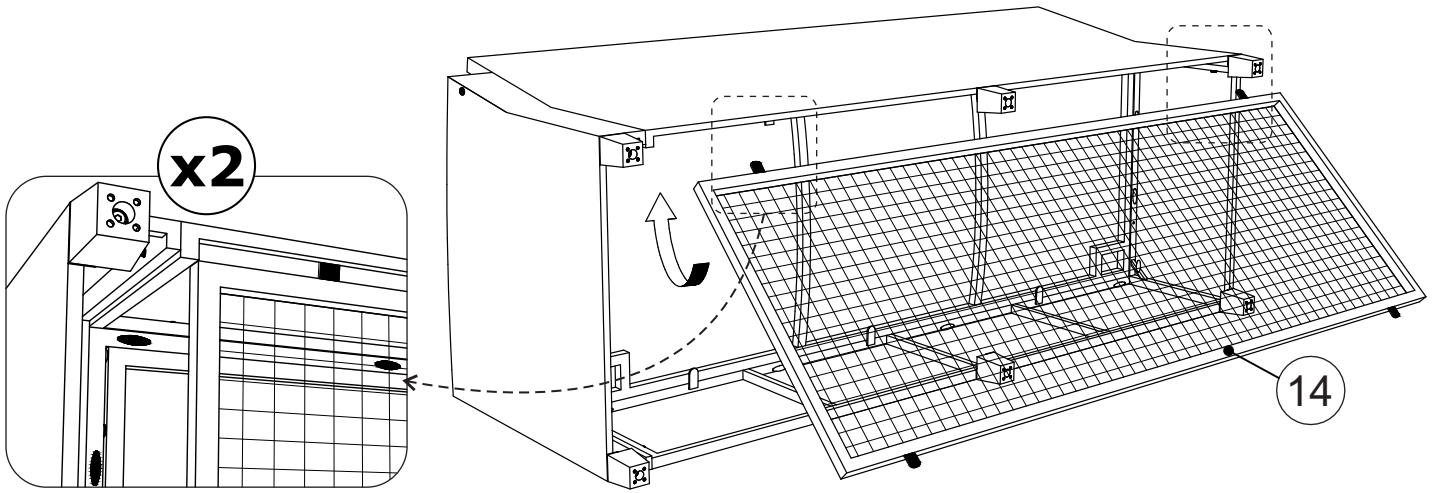

22



23
B x 2
D x 4
K x 2
J x 4
L x 2
M x 1
N x 2

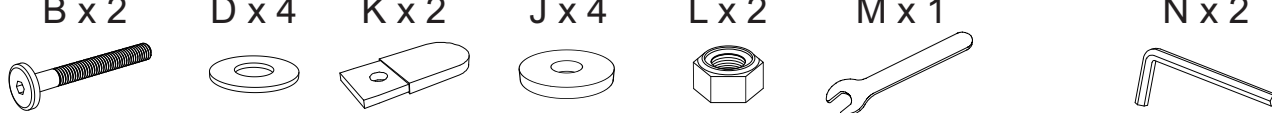
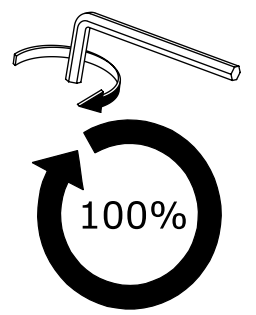
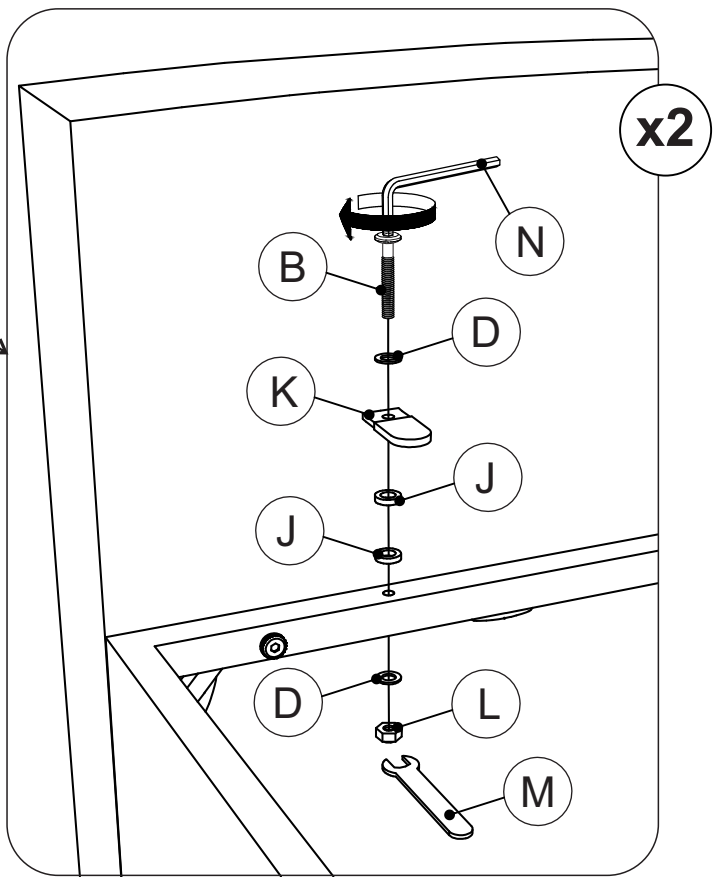
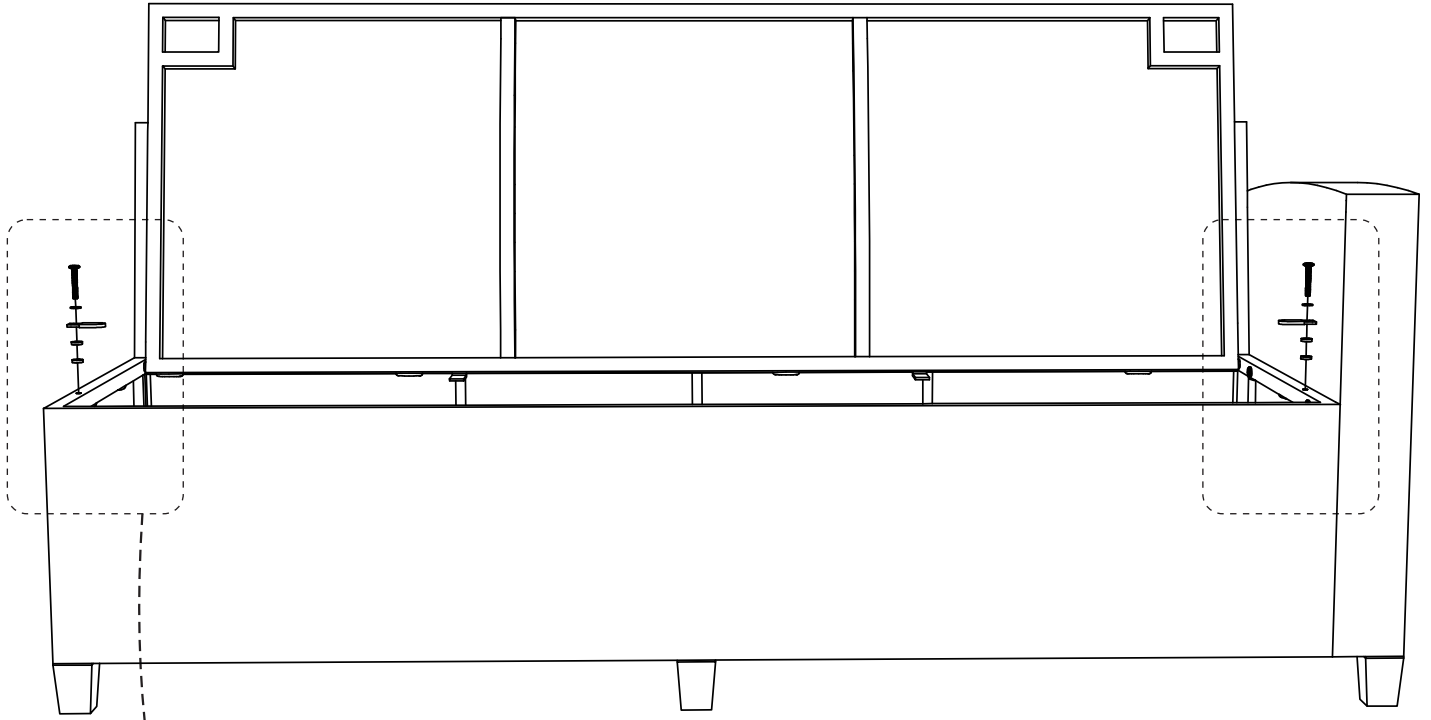

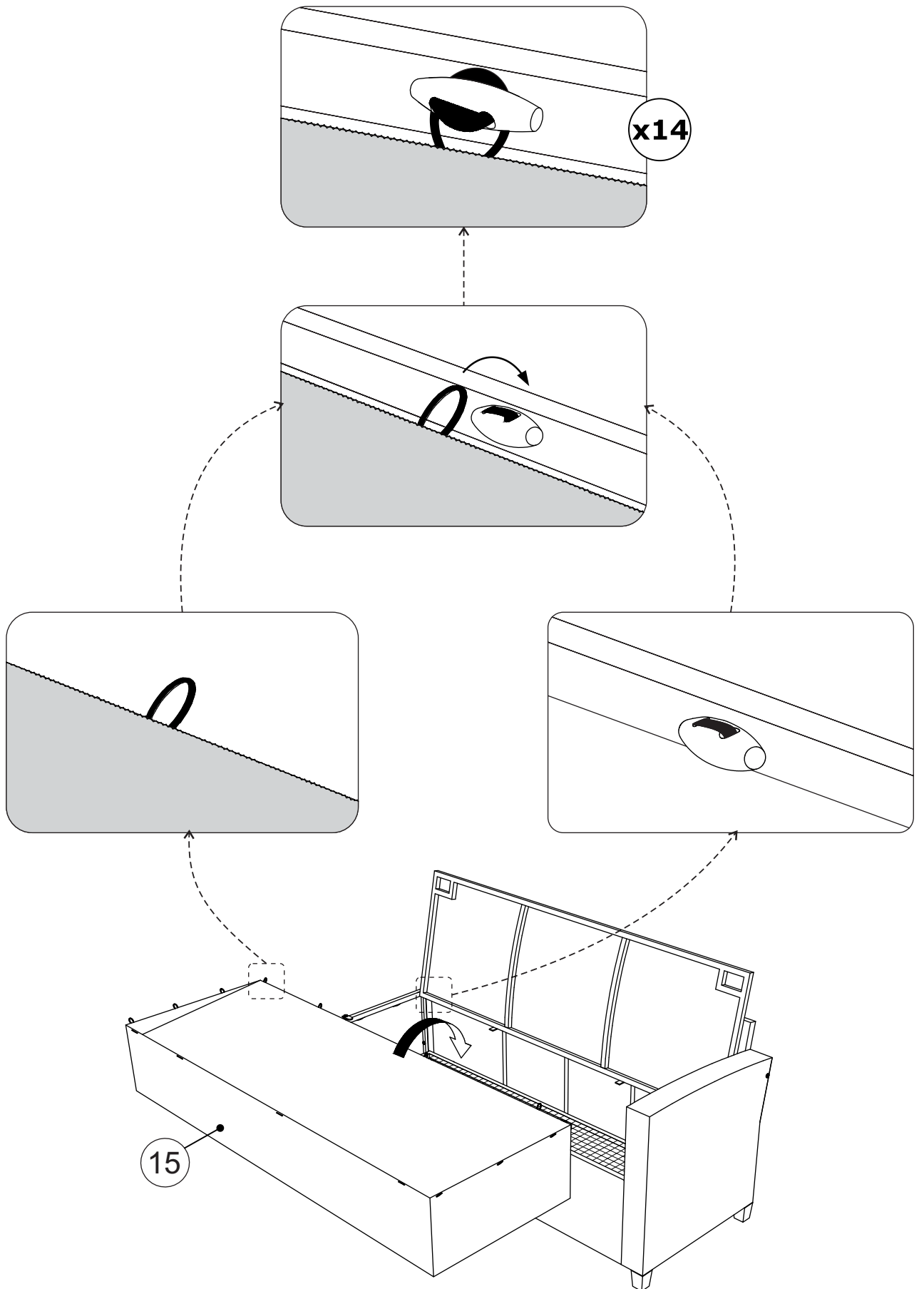
25

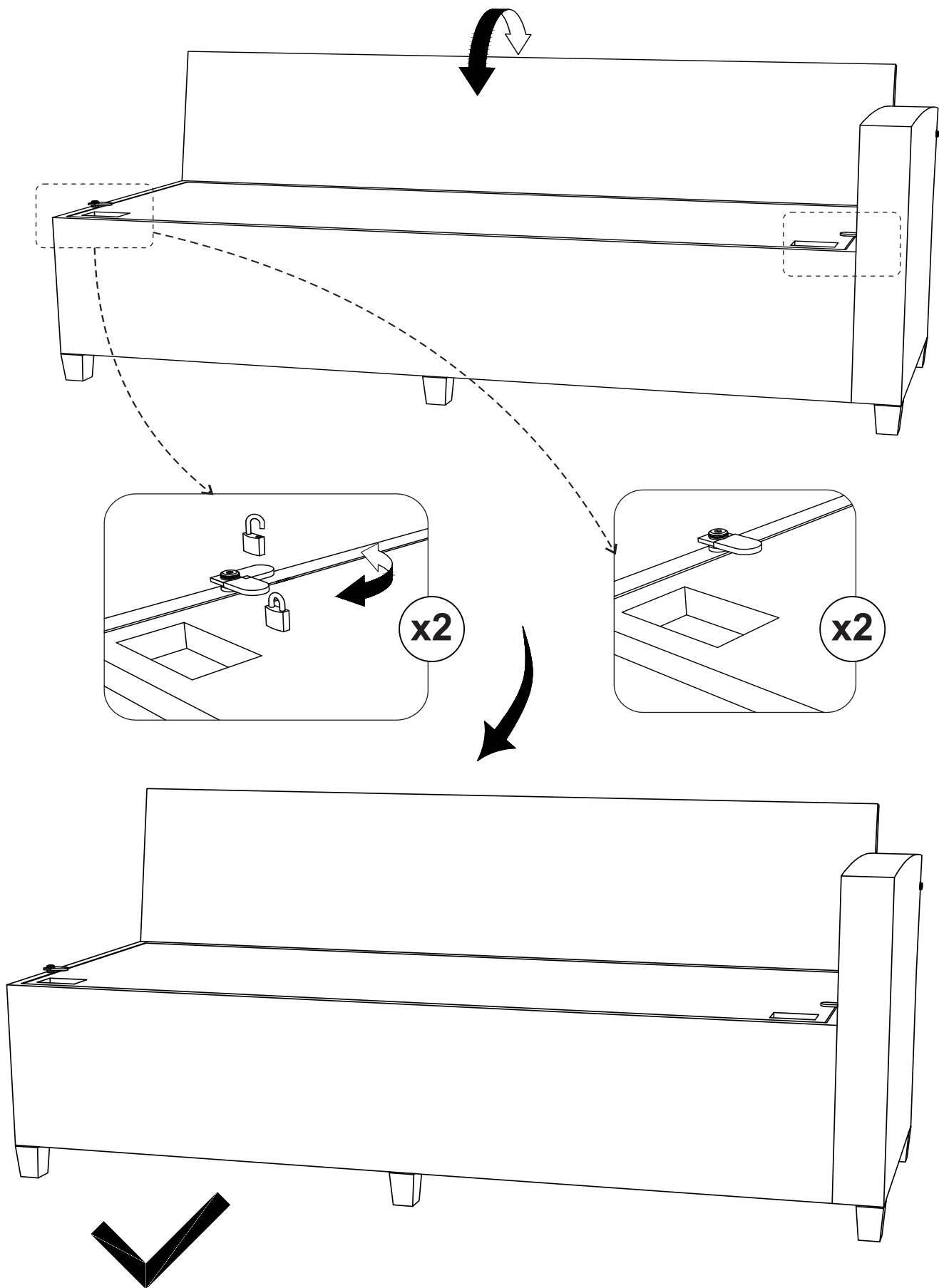

26

F x 2

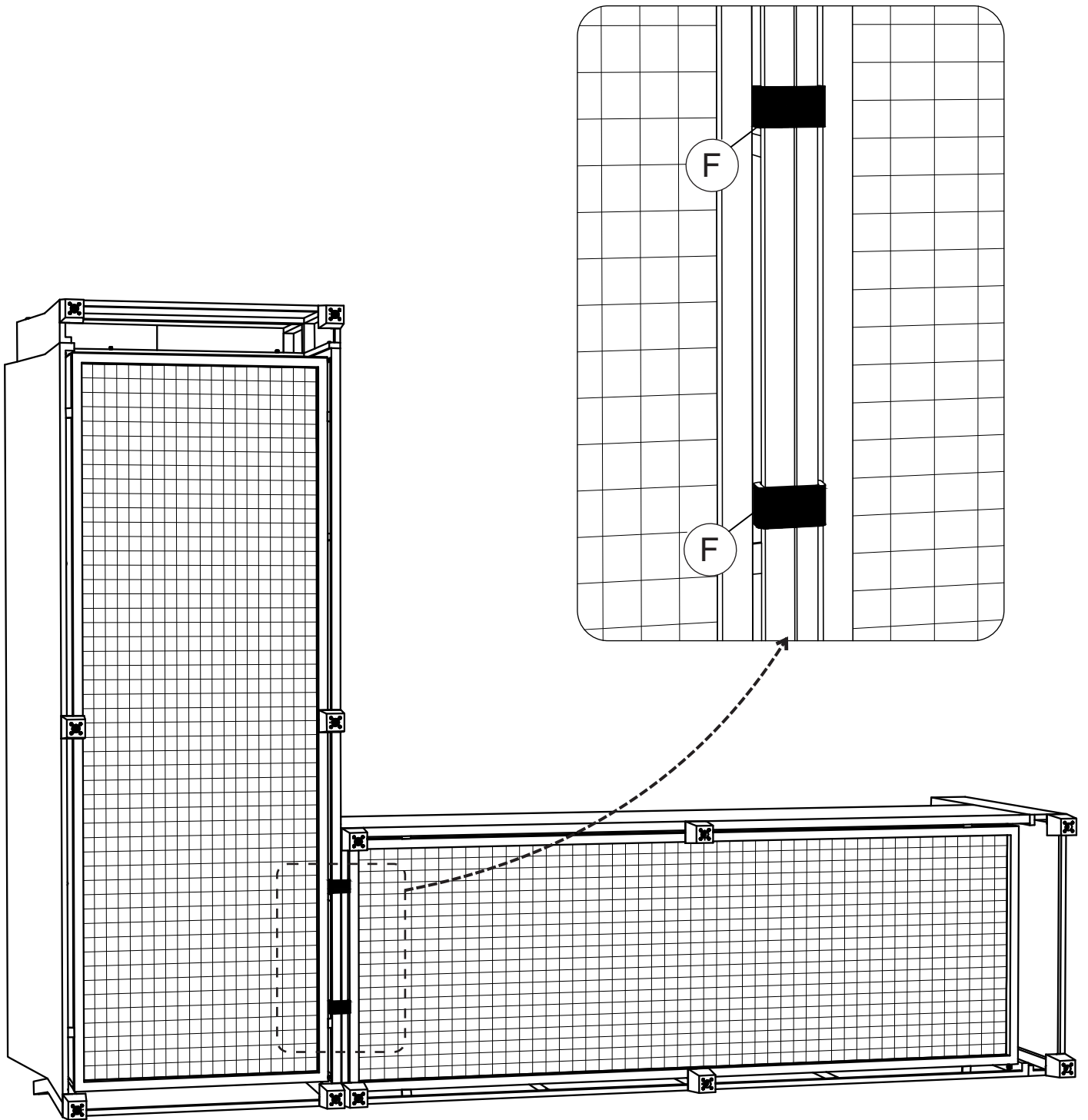

27

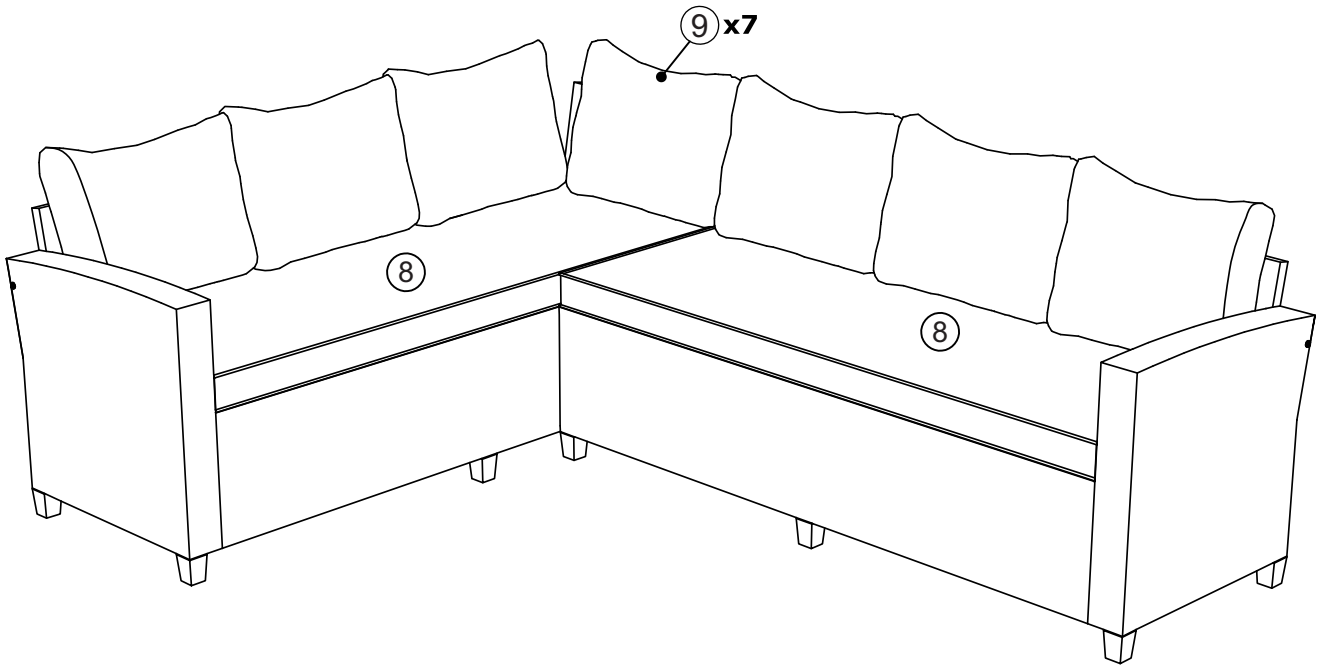

28

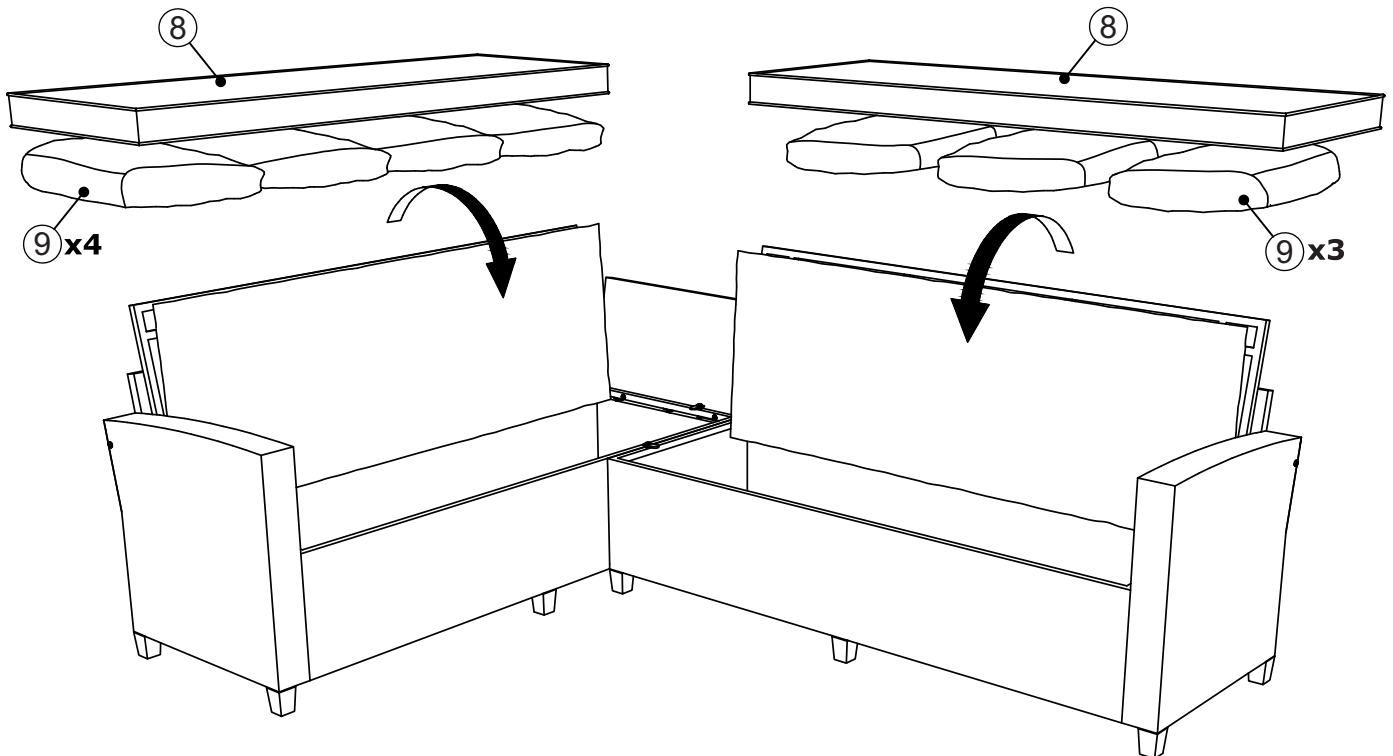

29 Ax2 Dx2 Nx2

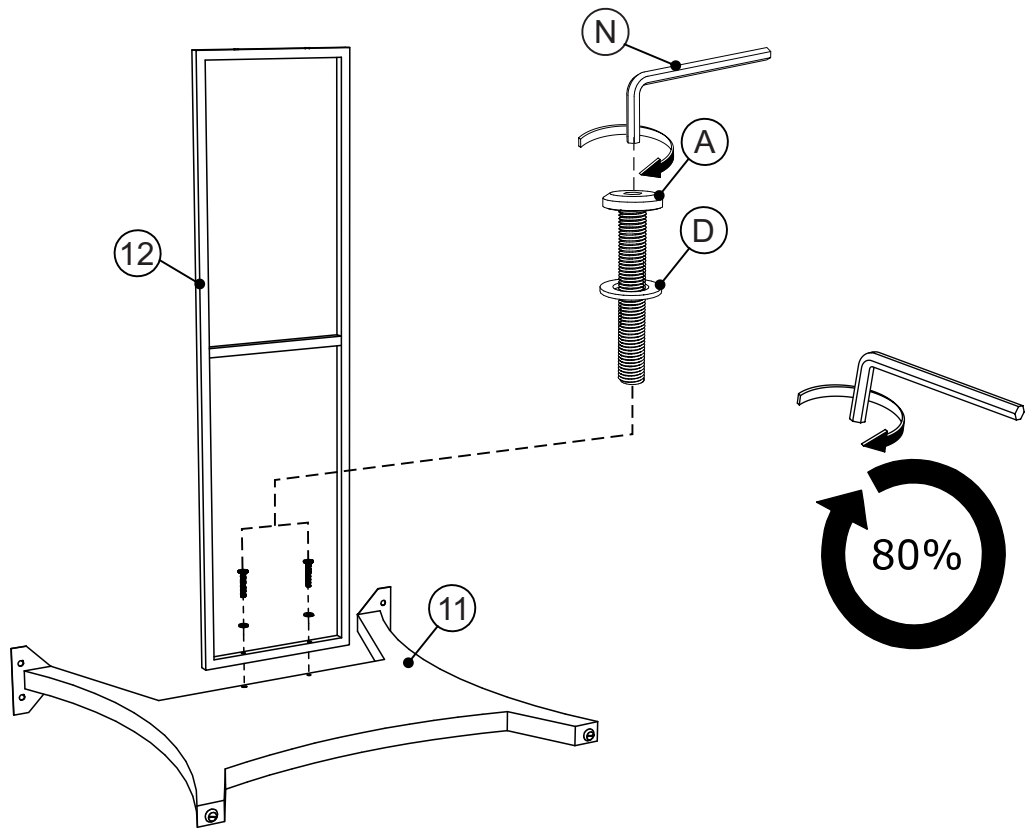
30 Ax2 Dx2 Nx2

31 G x 8 H x 8 N x 2

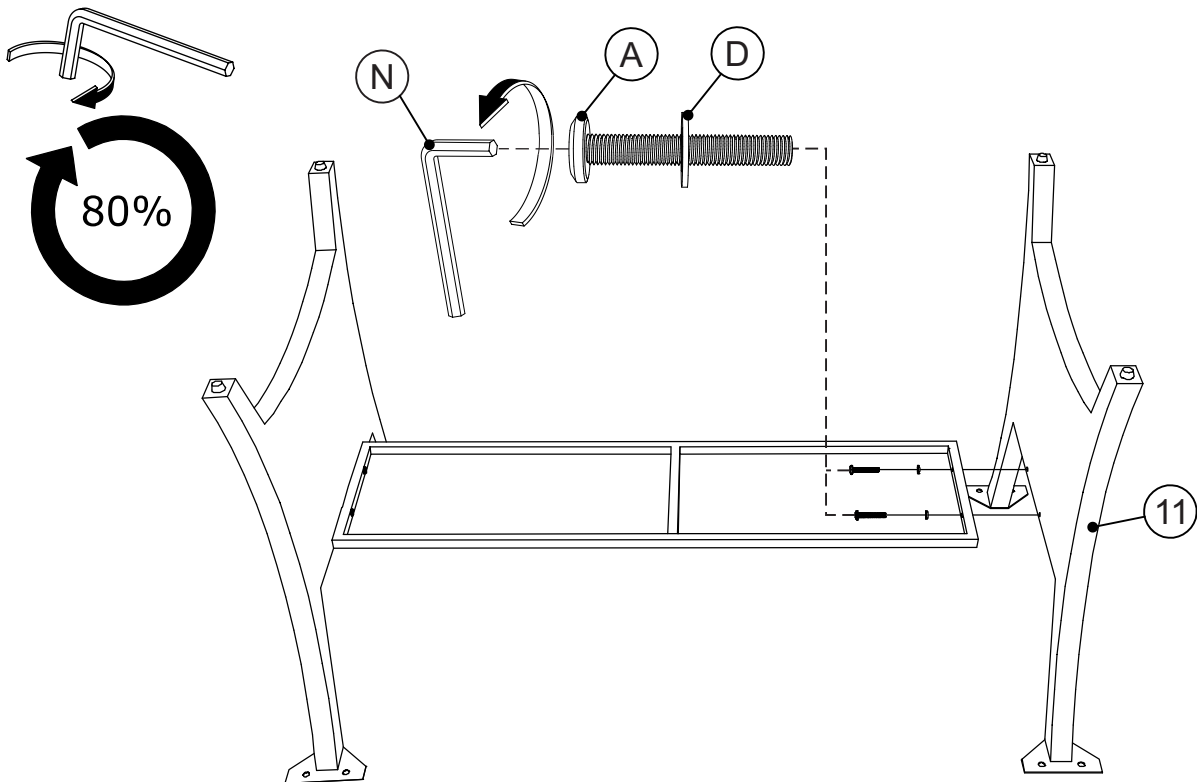
32 N x 2

33

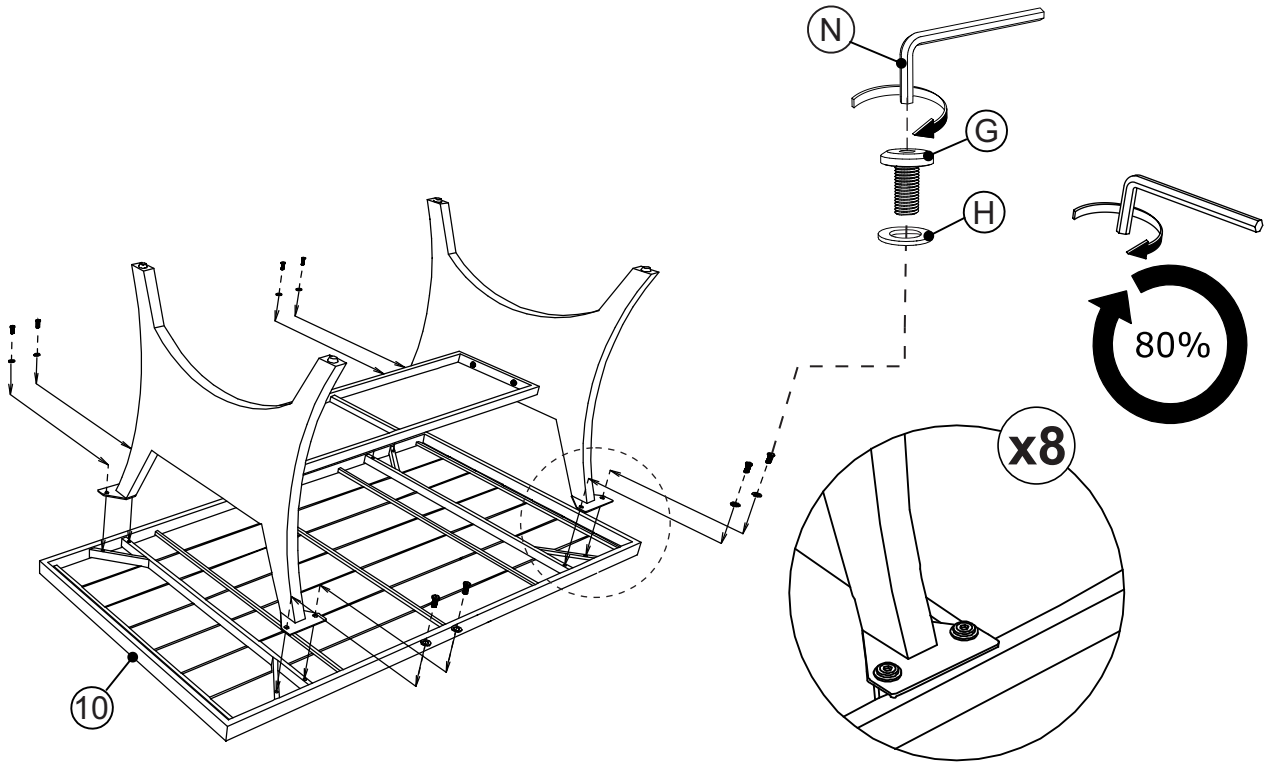

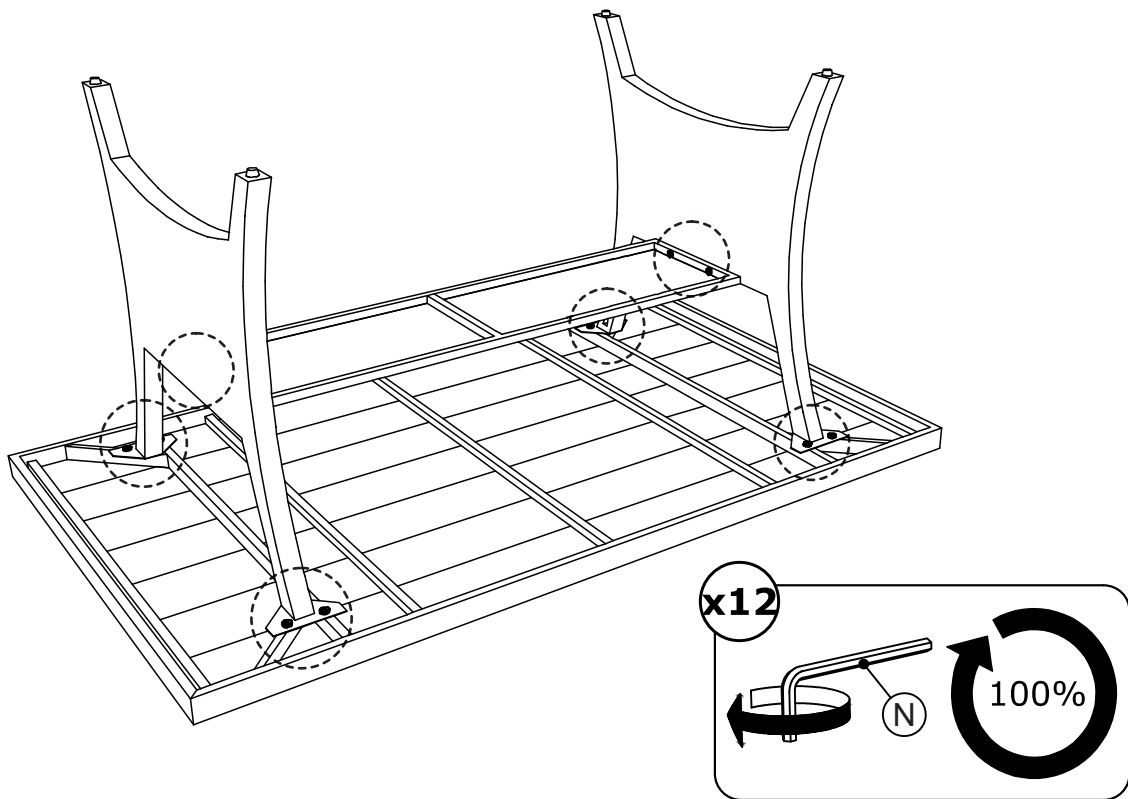
MAINTENANCE INSTRUCTIONS – OUTDOOR FURNITURE

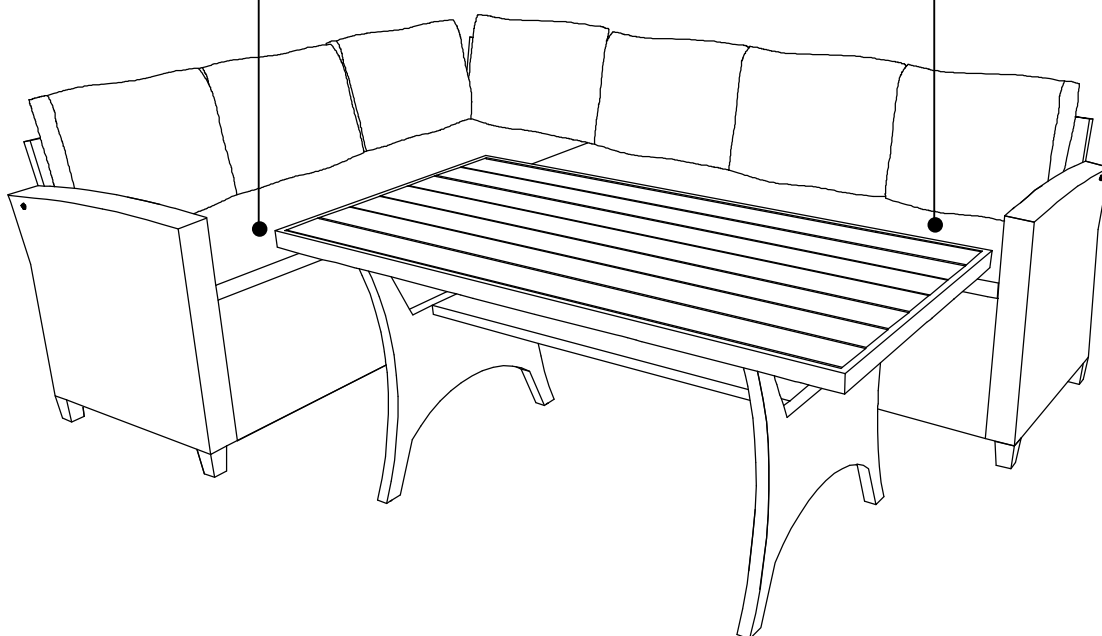
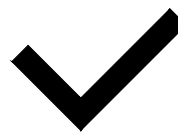
Congratulations on your new outdoor furniture, which will bring many years of joy if following the below recommendations and instructions.

Generally, protect and secure your outdoor furniture from harsh weather conditions and UV exposure.

When not in season, clean the furniture and store in a protected, dry and ventilated place. Make sure of good ventilation to prevent condensation and mildew.

General cleaning instructions: wipe clean with a clean damp cloth or soft sponge wrung in clean, lukewarm water. Do not use detergents, solvents, substances containing abrasives as they may cause scratches nor use other chemicals as this may cause discoloration. For soft covers and rope vacuum off dust and dirt, stains can be cleaned with mild soapy water, then leave to air dry. If removable covers refer to washing instructions.

All furniture assembled using screws must be re-tightened 2 weeks after assembly and once every 3 months in order to assure stability throughout the lifespan of the product.

Always ensure that the feet or felt pads provided with the product are suitable for your flooring.

Periodically check the position of the feet or felt pads used to ensure your floors are protected from scratches.

Do not place very hot or very cold objects directly on any surface and use coasters or similar for protection.

Color stains from eg. red wine or food must be wiped off immediately.

Exposure to direct sunlight can cause discoloration and premature aging – protective covers are recommended.

Placement of wooden furniture on grass or soil may lead to rotting – protect legs by using rubber foot caps.

CUSHIONS:

Seat cushions need to be turned, rotated and switched around to prevent deformation. Back cushions need to be plumped up frequently to keep their full and airy shape and to prevent deformation. Store in a dry, ventilated indoor space when not in use.

ARTIFICIAL WOOD SURFACES:

Glass items placed on artificial wood in direct sun can lead to burn marks and discoloration.

CONSIGNES D'ENTRETIEN – MOBILIER D'EXTÉRIEUR

Félicitations pour votre nouveau mobilier d'extérieur, qui vous donnera de nombreuses années de joie si vous suivez les recommandations et les consignes ci-dessous.

D'une manière générale, protégez et sécurisez votre mobilier d'extérieur des conditions météorologiques adverses et de l'exposition aux UV.

En fin de saison, nettoyez le mobilier et rangez-le dans un lieu abrité, sec et aéré. Assurez-vous qu'il y ait une bonne ventilation pour éviter la condensation et la moisissure.

Consignes générales de nettoyage : essuyez avec un chiffon propre et humide ou avec une éponge douce plongée dans de l'eau propre et tiède puis essorée. N'utilisez pas de détergents, de solvants ou de substances contenant des agents abrasifs, car ils peuvent provoquer des rayures. N'utilisez pas d'autres produits chimiques, car cela peut provoquer une décoloration. Aspirez la poussière et la saleté des housses souples et des cordes. Effacez les taches avec de l'eau savonneuse douce, puis laissez sécher à l'air libre. Si les housses sont amovibles, consultez les instructions de lavage.

Il est important de revisser tous les meubles montés avec des vis, 2 semaines après le montage et tous les 3 mois afin de garantir la stabilité pendant toute la durée de vie du produit.

Assurez-vous toujours que les pieds ou les patins en feutre fournis avec le produit conviennent à votre revêtement de sol. Vérifiez régulièrement la position des pieds ou des patins en feutre utilisés pour vous assurer que vos sols sont protégés des rayures.

Ne placez pas d'objets très chauds ou très froids directement sur une surface, et utilisez des sous-verres ou similaires pour la protéger.

Les taches de couleur causées par exemple par du vin rouge ou de la nourriture doivent être essuyées immédiatement.

L'exposition directe au soleil peut provoquer une décoloration et un vieillissement prématuré : il est recommandé d'utiliser des housses de protection.

L'installation de meubles en bois sur l'herbe ou la terre peut entraîner leur pourriture. Protégez les pieds avec des couvre-pieds en caoutchouc.

COUSSINS :

Les coussins de siège doivent être tournés, retournés et échangés pour éviter toute déformation. Les coussins de dossier doivent être fréquemment tapés pour les faire regonfler et éviter toute déformation. Entreposez-les dans un espace intérieur sec et aéré lorsqu'ils ne sont pas utilisés.

SURFACES EN BOIS ARTIFICIEL :

Les articles en verre posés sur du bois artificiel en plein soleil peuvent provoquer des marques de brûlure et une décoloration.

INSTRUCCIONES DE MANTENIMIENTO – MUEBLES DE EXTERIOR

Enhorabuena por su nuevo mueble de exterior, que le proporcionarán muchos años de alegría si sigue las siguientes recomendaciones e instrucciones.

En general, proteja y asegure sus muebles de exterior de las condiciones climáticas adversas y la exposición a los rayos UV. Cuando no los vaya a utilizar con asiduidad, limpie los muebles y guárdelos en un lugar protegido, seco y ventilado. Asegúrese de tener una buena ventilación para evitar la condensación y el moho.

Instrucciones generales de limpieza: limpie con un paño limpio y húmedo, o una esponja suave escurrida en agua limpia y tibia. No use detergentes, disolventes, sustancias que contengan abrasivos, ya que pueden causar rasguños. Tampoco utilice otros productos químicos, ya que esto puede causar decoloración. Para las fundas suaves y cordajes, aspire el polvo y la suciedad. Las manchas se pueden limpiar con agua jabonosa suave y luego deje secar al aire. Si las fundas son desmontables, consulte las instrucciones de lavado.

Todos los muebles montados con tornillos deben volver a apretarse 2 semanas después del montaje y una vez cada 3 meses para garantizar su estabilidad durante toda la vida útil del producto.

Asegúrese siempre de que las patas o almohadillas de fieltro proporcionadas con el producto sean adecuados para su tipo de suelo.

Revise periódicamente la posición de las patas o almohadillas de fieltro utilizadas para asegurarse de que su suelo esté protegidos de arañazos.

No coloque objetos muy calientes ni muy fríos directamente sobre ninguna superficie, y use posavasos o similares para proteger los muebles.

Las manchas de color del vino tinto o de la comida se deben limpiar inmediatamente.

La exposición directa a la luz solar puede causar decoloración y envejecimiento prematuro: se recomienda utilizar fundas protectoras.

La colocación de muebles de madera en el césped o el suelo puede hacer que la madera en contacto con el suelo se pudra; proteja las patas usando capuchones de goma.

COJINES:

Los cojines de los asientos se deben girar, rotar e intercambiar para evitar la deformación. Los cojines de espalda se deben rellenar con frecuencia para mantener su forma completa y aireada y para evitar su deformación. Cuando no los esté utilizando, almacénelos en un espacio interior seco y ventilado.

SUPERFICIES DE MADERAARTIFICIALES:

Los artículos de vidrio colocados sobre madera artificial bajo el sol directo pueden provocar marcas de quemaduras y decoloración.