

IRONAX™ ALL-IN-ONE

Smith Machine | Power Rack | Leg Press | Functional Trainer

The IRONAX All-In-One Trainer combines four essential training systems into a single, compact footprint, making it the ultimate home and light commercial gym solution. Whether you're focusing on strength, functional fitness, or muscle sculpting, this machine delivers unmatched versatility and durability.

Key Features

- Comprehensive Workout Options – Train every major muscle group with cable crossovers, leg presses, low rows, and more.
- Smooth Weight Stacks – 2 x 120 lbs stacks (equivalent to 240 lbs each at a 2:1 ratio) with high-tensile aircraft-grade cables for consistent performance.
- Smith Machine & Power Rack – Includes spotter arms for safety and J-hooks for free-weight training.
- Leg Press Attachment – Oversized, slip-resistant footplate with adjustable height settings.
- Low Row Footplate – Anti-slip texture ensures stability during rowing exercises.
- Heavy-Duty Construction – Black powder-coated steel frame for long-lasting durability.

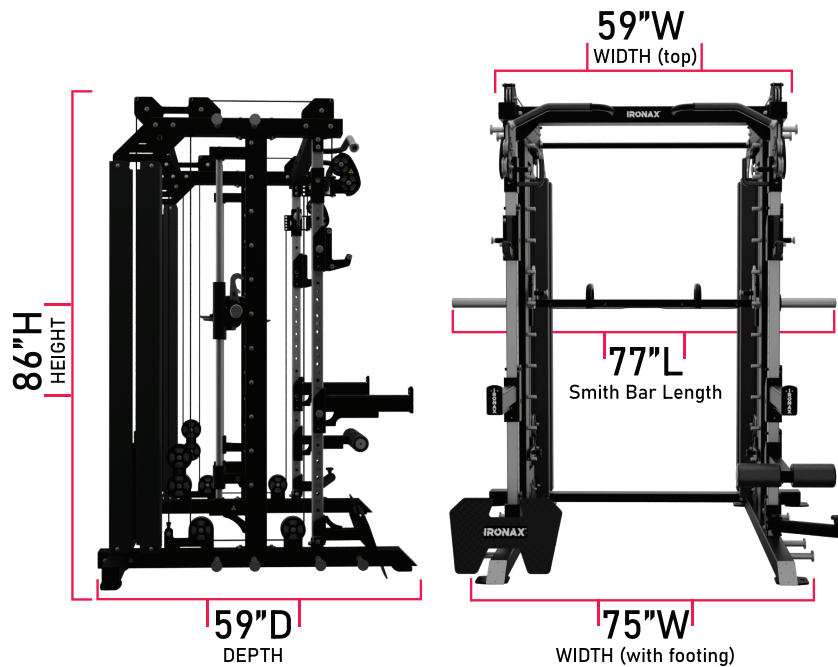

Specifications

- Dimensions: 58" W x 75" D (77.5" with Smith bar) x 86" H
- Weight Stack: 2 x 120 lbs (equivalent to 2 x 240 lbs at 2:1 ratio)
- Total Weight: 990 lbs
- Cable Ratio: 2:1 for smooth, controlled resistance
- Cable Strength: 2000 lbs tensile rating
- Usage: Light Commercial & Residential

The Ultimate Home Gym Solution

The IRONAX All-In-One is designed to replace multiple machines with one space-saving system. Whether you're a beginner or an advanced lifter, this powerhouse maximizes your workout potential while minimizing space—everything you need for full-body training in one machine.