

# MS19DG8500MTAC

SAMSUNG

## 1.9 cu. ft. Countertop Microwave and Trim Kit for Built-in Applications

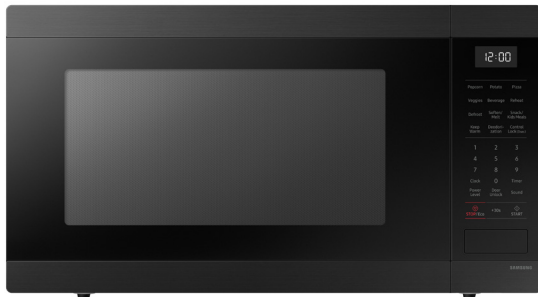

### Available Colours



Matte Black Stainless Steel (shown)



Stainless Steel

### Signature Features

#### 1.9 cu. ft. Capacity

- Accommodates a variety of dishes so you can prep large meals quickly.

#### SensorCook

- Automatically adjusts cooking time for optimal results.

#### Easy Clean Interior

- The smooth and durable Ceramic Enamel is easy to keep clean without scrubbing and won't discolour over time. It is highly rust and scratch-resistant, so it lasts longer.

#### Door AutoLock

- The Door AutoLock, which is compliant with the CSA standards, automatically locks the microwave oven door when it begins cooking and prevents it from being opened until 10 seconds after the unlock button on the control panel is pressed.\*



Sensor Cook

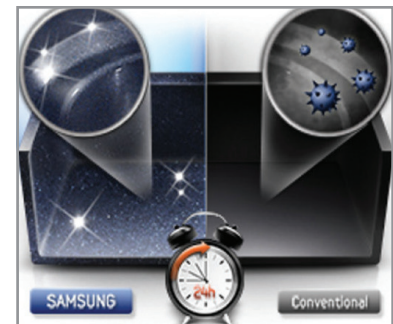

Ceramic Enamel Interior

### Features

- Eco Mode
- Cooking Presets
- 900W of Cooking Power
- 10 Power Levels
- Door AutoLock
- Auto Defrost
- LED Display
- 30" Matching Trim Kit (see next page for details.)

### Convenience

- Kitchen Timer
- Clock (12hr/24hr) with Daylight Saving Time Adjustment
- Child Safety Lock
- Reminder End Signal

# MS19DG8500MTAC

## 1.9 cu. ft. Countertop Microwave and Trim Kit for Built-in Applications

### Dimensions



### Side View

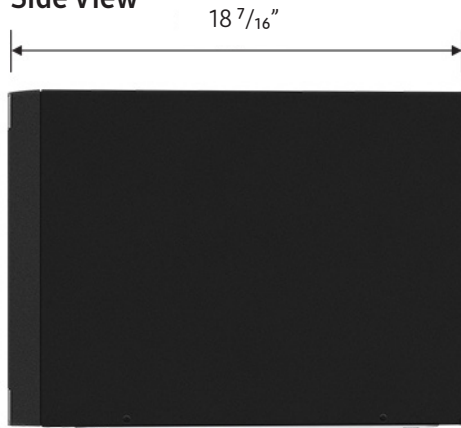

### Trim Kit

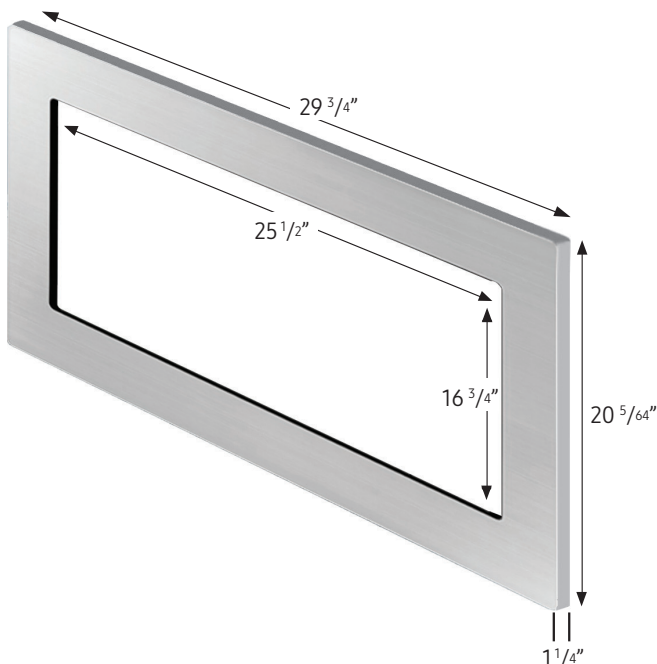

### Specifications

- Oven Cavity: 1.9 cu. ft.
- Power Output: 900W
- Power Consumption: 1500W/13.3 A
- Power Source: 120V / 60 Hz
- Control Method: Electronic Touch
- Display: LED (Ice Blue)
- Cooking Control: 10 Power Levels Including Defrost
- Cooking Timer: Digital, up to 99 Minutes, 99 Seconds
- Microwave Distribution System: Turntable

### Warranty

One (1) Year Parts and Labour  
Five (5) Years on Magnetron Microwave Technology

### Microwave Product Dimensions & Weight (WxHxD)

Outside Dimensions: 23 5/8" x 13 5/16" x 18 7/16"  
Interior Cavity Dimensions: 17 2/3" x 10 5/6" x 17 5/6"  
Weight: 44.1 lb. (20.0 kg)

### Trim Kit Dimensions (WxHxD)

Outside Dimensions: 29 3/4" x 20 5/64" x 1 1/4"  
Cut Out (WxH): 25 1/5" x 16 3/4"  
Weight: 12.83 lb. (5.81 kg)

### Microwave Shipping Dimensions & Weight (WxHxD)

Dimensions: 26 1/4" x 16 7/16" x 20 1/4"  
Weight: 48.9 lb. (22.2 kg)

### Trim Kit Shipping Dimensions (WxHxD)

Dimensions: 22 3/4" x 6 3/4" x 33 5/32"  
Weight: 16.78 lb. (7.6 kg)

### Countertop Microwave and Trim Kit for Built-in Applications

For installation with Wall Ovens, respective codes must be paired together:

Colour	Product:	Model #	UPC Code
Matte Black	Microwave	MS19DG8500MTAC	887276868875
Stainless Steel	Microwave	MS19DG8500SRAC	887276868899
Matte Black	Trim Kit	MA-TK8020TG	887276263021
Stainless Steel	Trim Kit	MA-TK8020TS	887276263038