

30" Electric Slide-in Range



100 Series – Stainless Steel HEF1050MC



HEF1050MC
Stainless Steel

Experience culinary precision with the NEW Bosch 100 Series electric slide-in range which seamlessly blends cutting edge performance and timeless design for any budget, all with Bosch quality.

Features & Benefits

Rapid pre-heat reaches 350°F before you finish your prep.

All-in-One Range delivers all the cooking versatility without the countertop clutter: Air Fry, Quick Meal, Bake, Broil, Pizza Oven, Convection Bake, Convection Roast, Dough Proof, Keep Warm.

Powerful center oval burner is ideal for large pans and griddles.

Steam-assist cleaning cycle for quick upkeep, and self-clean cycles for deep cleaning.

Easy installation: the slide-in design replaces existing range cutouts and slides back against the wall for a finished look.

Sleek backlit user interface wakes up when prompted.

General Properties

Cooking modes	Air Fry, Bake, Broil, Convection Bake, Convection Broil, Pizza, Proof, Quick Meal, Keep Warm
Cleaning type	Self-clean (2h, 3h, 5h) & Steam-assist clean
Type of surface	Ceramic Glass
Interior light	1
Kitchen timer	Yes
Drawer type	Storage

Oven Performance

Bake / broil element watts	3,000 / 3,400 W
Convection element watts	1,500 W

Element Performance

Total cooktop elements	4 + warming zone
Power of front left element watts	3,000 W
Power of back left element watts	1,200 W
Power of center element watts	Warming zone 100 W
Power of back right element watts	1,200 W
Power of front right element watts	3,000 W

Element Size

Dimension of front left heating element	9"
Dimension of back left heating element	6"
Dimension of center heating element	6"
Dimension of back right heating element	6"
Dimension of front right heating element	12"



Technical Details

Watts	13,500 / 10,200 W
Circuit breaker	40 A
Volts	208 V / 240 V
Frequency	60 Hz
Plug type / Cord length	4-prong plug / 1.4m
Energy source	Electric

Dimensions & Weight

Overall appliance dimensions (HxWxD)	36" x 29 7/8" x 26 1/2" w/o handle
Required cutout size (HxWxD)	36" x 30" x 25"
Adjustable range height	3/4"
Oven cavity size	5.8 cu. ft.
Overall oven interior dimensions (HxWxD)	24 3/16" x 21 1/8" x 19 13/16"
Usable oven interior dimensions (HxWxD)	23 5/8" x 20 3/16" x 18 3/8"
Net weight	153.4 lbs

Accessories – Included

Use and care manual, installation guide, 2 standard racks, anti-tip protection kit

† To be fully ADA compliant, these units must be installed according to ADA guidelines. Please check current ADA requirements for guidance on installation.

Accessories: To purchase Bosch accessories, cleaners & parts please call 1-800-944-2904 (Mon to Fri 5 am to 6 pm PST, Sat 6 am to 3 pm PST).

Notes: All height, width and depth dimensions are shown in inches. BSH reserves the absolute and unrestricted right to change product materials and specifications, at any time, without notice. Consult the product's installation instructions for final dimensional data and other details prior to making cutout.

Warranties: Please see Use & Care manual or Bosch website for statement of limited warranty.

For more information on our entire line of products, go to www.bosch-home.ca or call 1-800-944-2904

© BSH Home Appliances Corporation. All rights reserved. Bosch is a registered trademark of Robert Bosch GmbH.

12/24 CA

30" Electric Slide-in Range



100 Series – Stainless Steel HEF1050MC

Installation Details

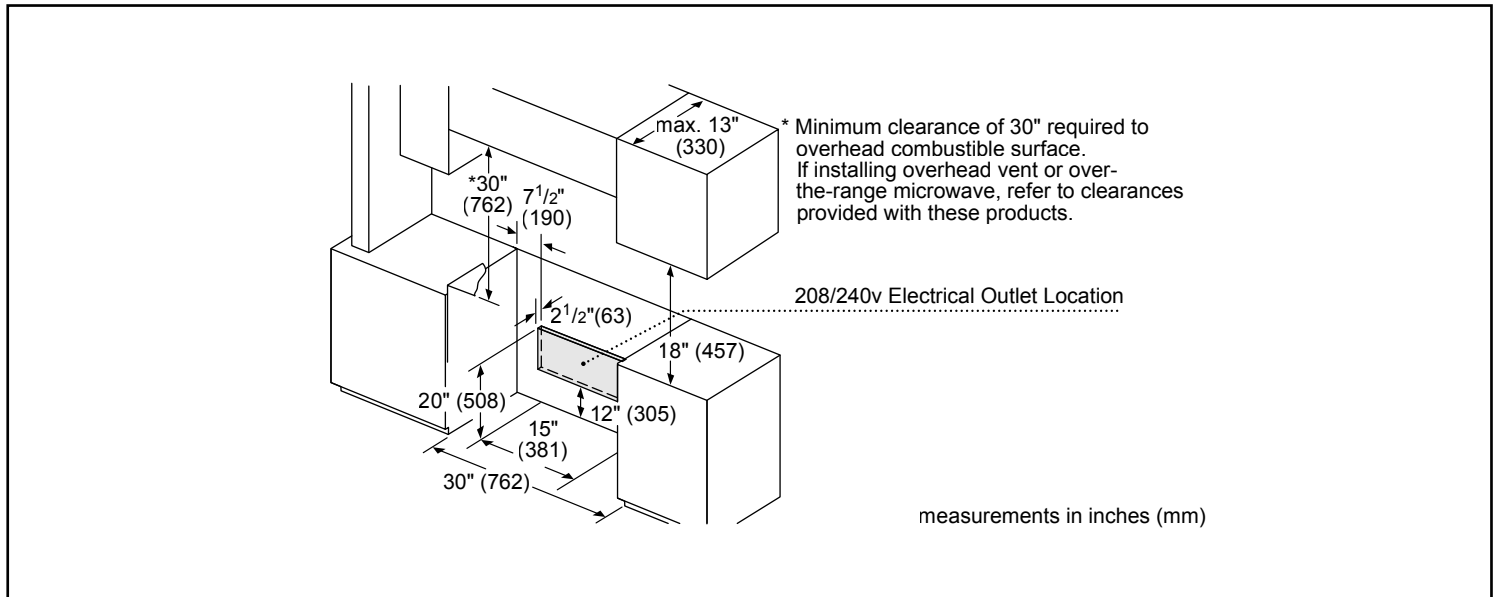
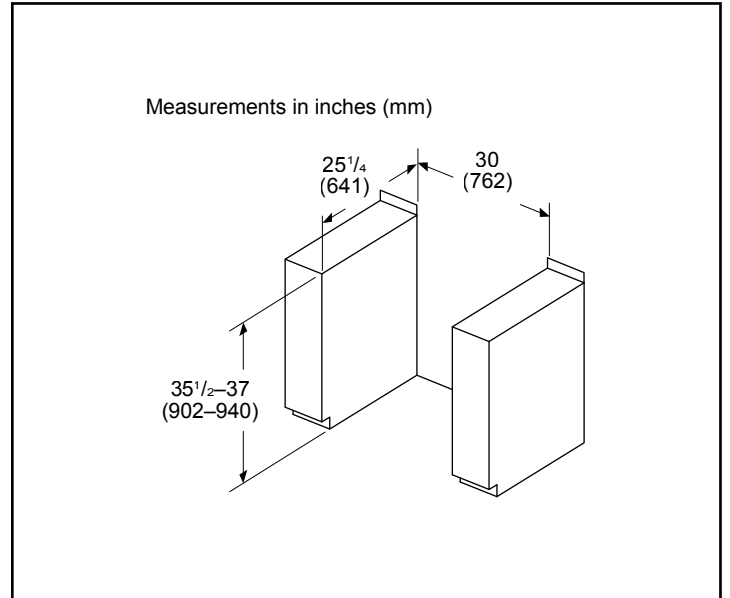
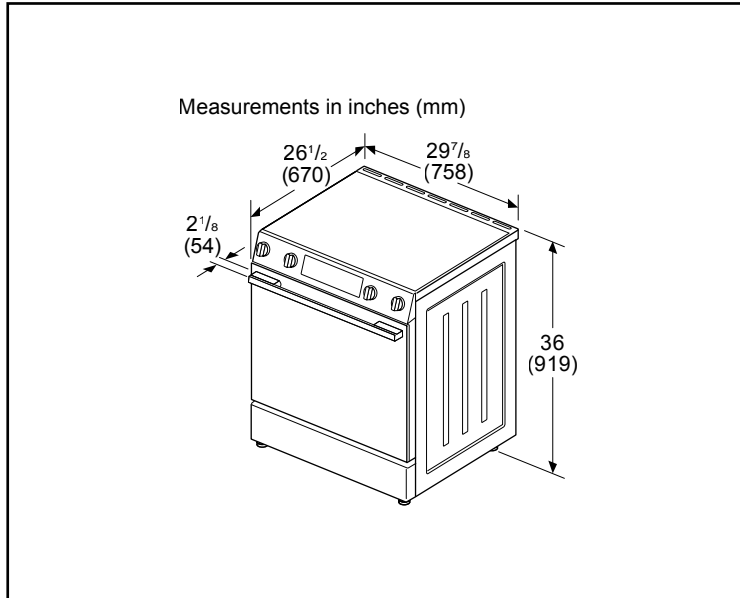

Accessories: To purchase Bosch accessories, cleaners & parts please call 1-800-944-2904 (Mon to Fri 5 am to 6 pm PST, Sat 6 am to 3 pm PST).

Notes: All height, width and depth dimensions are shown in inches. BSH reserves the absolute and unrestricted right to change product materials and specifications, at any time, without notice. Consult the product's installation instructions for final dimensional data and other details prior to making cutout.

Warranties: Please see Use & Care manual or Bosch website for statement of limited warranty.

For more information on our entire line of products, go to www.bosch-home.ca or call 1-800-944-2904

© BSH Home Appliances Corporation. All rights reserved. Bosch is a registered trademark of Robert Bosch GmbH.