

# SOU2300TX

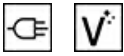

Category	60cm
Product Family	Oven
Power supply	Electric
Cooking method	Thermo-ventilated
Cleaning system	Vapor Clean
EAN code	8017709341954



## Aesthetics

Aesthetic	Classica	Type of steel	Brushed
Colour	Stainless steel	Serigraphy colour	Black
Finishing	Fingerproof	Serigraphy type	Symbols and wordings
Design	Flat	Handle Colour	Inox
Material	Stainless steel	Logo	Embossed

## Controls



Display name	DigiScreen	Display technology	LED
--------------	------------	--------------------	-----

## Programs / Functions

No. of cooking functions 8

Traditional cooking functions

Static	Fan assisted	Circulaire
Turbo	Eco	Large grill
Fan grill (large)	Base	

Other functions

Defrost by time
-----------------

## Cleaning functions

 Vapor Clean

## Options



**Time-setting options** Delay start and automatic end cooking

**Minute minder** Yes

**Timer** 1

**Rapid pre-heating** Yes

## Technical Features



**Minimum Temperature** 100 °F

**Maximum temperature** 500 °F

**No. of shelves** 5

**N. of fans** 1

**No. of lights** 2

**Light type** Halogen

**User-replaceable light** Yes

**Light Power** 40 W

**Light when door is opened** Yes

**Lower heating element power** 1200 W

**Upper heating element - Power** 1000 W

**Grill element - power** 1700 W

**Large grill - Power** 2700 W

**Circular heating element - Power** 1550 W

**Heating suspended when door is opened** Yes

**Door** Temperate door

**Removable inner door** Yes

**Total no. of door glasses** 3

**Cooling system** Tangential

**Cooling duct** Double

**Speed Reduction** Yes

**Cooling System**

**Cavity material** Ever clean Enamel

## Performance / Energy Label



**Net volume of the cavity** 2.54 cu. ft.

## Accessories Included



**Rack with back stop** 2

**Enamelled deep tray (40mm)** 1

**Insert gird** 1

**Telescopic Guide rails, partial Extraction** 1

## Electrical Connection

**Plug** Cable with free ends

**Voltage** 120/240 V

**Nominal power** 3400 W

**Current 2** 13 A

**Frequency (Hz)** 60 Hz

Voltage 2

120/208 V

Power supply cable  
length

59 1/16 "

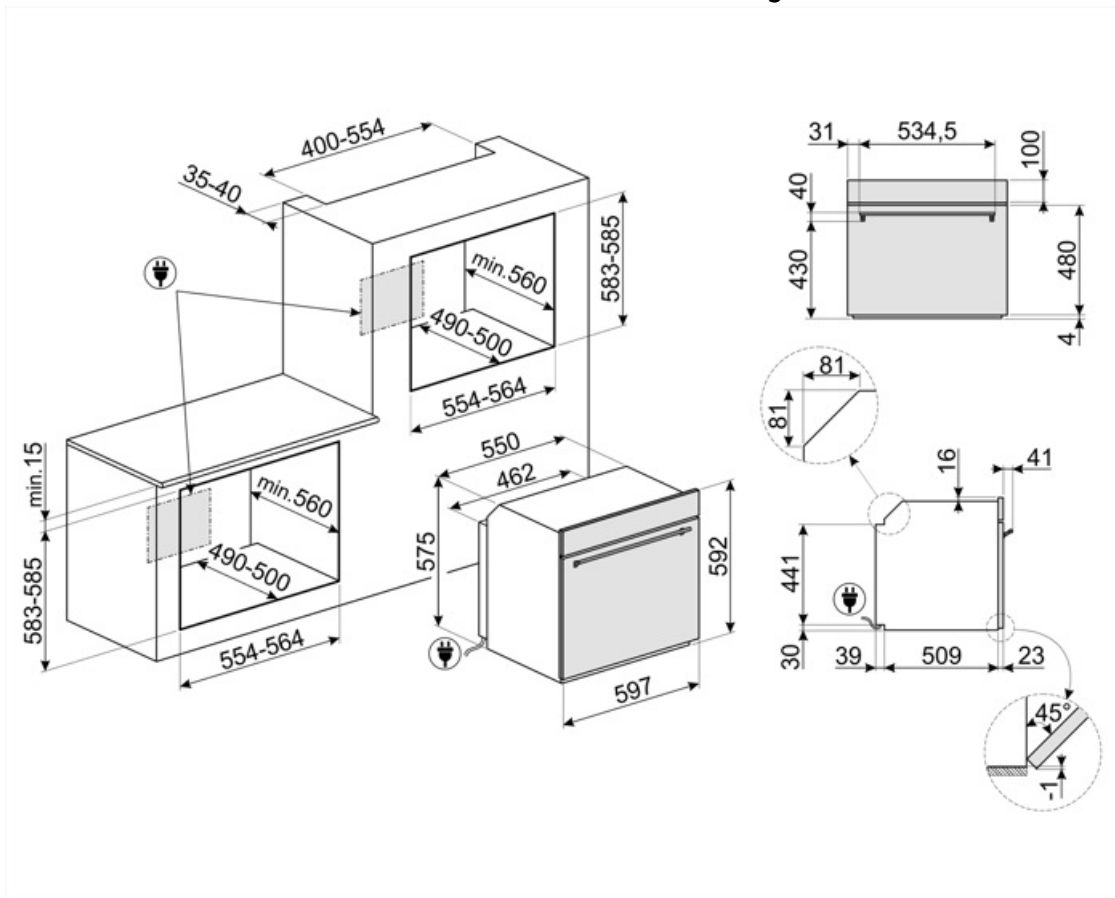

---

## Compatible Accessories

---

### BN620-1



Enamelled tray suitable for 45cm and 60cm ovens. Depth 20 mm. Perfect for a wide range of savoury and sweet baking.

### GTP



Partially extractable telescopic guides (1 level), suitable for traditional ovens. Made in stainless steel, they guarantee stability and facilitate the smooth extraction of the trays.

### PALPZ



Pizza shovel with folding handle. Dimensions L31.5 x H32.5 cm. Easy and convenient to use and store. Perfect for serving pizza, bread and savory pastries in a safe and professional way.

### BN640



Enamelled tray suitable for 45cm and 60cm ovens. Depth 540 mm. Perfect for cooking and roasting meat and fish in sauces. Also ideal for experimenting with lighter and crunchy side dishes

### GTT

















Totally extractable telescopic guides (1 level), suitable for traditional ovens. Made in stainless steel, they guarantee stability and facilitate the smooth extraction of the trays.











### PR3845X



Antifingerprint stainless steel. Cover for furniture in column installation of more ovens

## Symbols glossary

 <p>A: Product drying performance, measured from A+++ to D / G depending on the product family</p>	 <p>Air cooling system: to ensure a safe surface temperatures.</p>
 <p>Defrost by time: Manual defrost function. At the end of the set duration, the function stops.</p>	 <p>Triple glazed doors: Number of glazed doors.</p>
 <p>Electric</p>	 <p>Ever Clean Enamel: Ever Clean enamel is applied electrostatically, corner to corner and edge to edge to prevent cracking or cracks over time. It is a particular pyrolytic enamel, resistant to acids which, in addition to being pleasantly bright, promotes greater cleaning of the oven walls, thanks to its lower porosity. It is baked at over 850 ° C and slowly polymerized at a scientifically determined rate to ensure uniform depth and strength Ever Clean enamel creates an impeccable finish both on the inside of the oven and on the trays, making the surfaces of the oven incredibly easy to maintain over time as it reduces the adhesion of fat during cooking</p>
 <p>Fingerprint proof stainless steel: Fingerprint proof stainless steel keeps stainless steel looking as good as new.</p>	 <p>Fan assisted: Intense and homogeneous traditional cooking, also suitable for complex recipes. The fan is active and the heat comes from below and from above at the same time. Ventilated cooking ensures a faster and more homogeneous result, leaving fragrant foods outside and moister inside. Ideal for baked pasta, biscuits, roasts and cobblers.</p>
 <p>Static: Traditional cooking suitable for the preparation of one dish at a time. The fan is not active and the heat comes from below and from above at the same time. Static cooking is slower and more delicate, ideal in order to get well cooked and dry dishes even inside. Ideal for cooking all types of roasts, fatty meats, bread, filled cakes.</p>	 <p>Base: the heat comes only from the bottom of the cavity. The fan is not active. Ideal for sweet and savory pies, cobblers and pizzas. Designed to complete cooking and make food more crunchy This symbol in gas ovens indicates the gas burner.</p>
 <p>Circulaire: it is the perfect function for cooking all types of dishes in a more delicate way. The heat comes from the back of the oven and is distributed quickly and evenly The fan is active. It is also ideal for cooking on multiple levels without mixing smells and flavors.</p>	 <p>ECO: low energy consumption cooking: this function is particularly suitable for cooking on a single shelf with low energy consumption. It is recommended for all types of food except those that can generate a lot of moisture (for example vegetables). To achieve maximum energy savings and reduce time, it is recommended to put the food in the oven without preheating the cooking compartment</p>
 <p>Grill: Very intense heat coming only from above from a double heating element. The fan is not active. Provides excellent grilling and gratinating results. Used at the end of cooking, it gives a uniform browning to dishes.</p>	 <p>Fan grill: very intense heat coming only from above from a double heating element The fan is active. It allows the optimal grilling of thickest meats. Ideal for large cuts of meat.</p>

- 
- |   |   |
|---|---|
|  <p>Turbo: the heat comes from 3 directions: above, below and from the back of the oven The fan is active. It allows quick cooking, even on several shelves without mixing the aromas. Ideal for large volumes or foods that require intense cooking.</p> |  <p>All glass inner door: All glass inner door, a single flat surface which is simple to keep clean.</p> |
|  <p>The inner door glass: can be removed with a few quick movements for cleaning.</p>   |  <p>Side lights: Two opposing side lights increase visibility inside the oven.</p>                       |
|  <p>Rapid preheating: cooking is preceded by the preheating phase which allows the cooking compartment to reach the set temperature. This option reduces the time by up to 50%.</p>   |  <p>The oven cavity has 5 different cooking levels.</p>  |
|  <p>Telescopic rails: allow you to pull out the dish and check it without having to remove it from the oven entirely.</p>   |  <p>Vapor Clean: a simple cleaning function using steam to loosen deposits in the oven cavity.</p>       |
|  <p>The capacity indicates the amount of usable space in the oven cavity in litres.</p>   |  <p>The capacity indicates the amount of usable space in the oven cavity in litres.</p>                  |
|  <p>4.3 inch display with LED technology, usability with knobs + 3 touch keys</p>  |   |