

Cuisinart®

ESPRESSO BAR™

Espresso Machine

EM-320 SERIES



Instruction
& Recipe
Booklet

For your safety and continued enjoyment of this product, always read the instruction book carefully before using.

Important Safeguards

We at Cuisinart are very safety conscious. We design and manufacture consumer products with the safety of you, our valued customer, foremost in mind. In addition we ask that you exercise a degree of care when using electrical appliances and adhere to the following precautions.

When using electrical appliances, basic safety precautions should always be followed, including the following:

1. **CAREFULLY READ ALL INSTRUCTIONS BEFORE OPERATING APPLIANCE AND SAVE FOR FUTURE REFERENCE.**
2. To protect against fire, electrical shock, and injury to persons, do not immerse the appliance, cord, or plug in water or any other liquid.
3. This appliance is for household use only.
4. Do not use this appliance for anything other than its intended use.
5. Do not leave the appliance unattended when in use.
6. Do not touch hot surfaces. Use handles or knobs.
7. Always use the appliance on a dry, level surface.
8. To disconnect, turn all controls off, then remove plug from power outlet.
9. Do not place this appliance on or near a hot gas or electric burner, or where it could touch a heated oven.
10. Do not let the cord hang over the edge of a table or counter, touch hot surfaces, or become knotted.
11. The use of accessory attachments not recommended by Cuisinart may cause a risk of injury to persons, fire, or electrical shock.
12. Strictly follow cleaning and care instructions.
13. Do not use outdoors.
14. An extension cord is not recommended. However, if one is needed, the extension cord should be a grounded type and its electrical rating must be the same or higher wattage as the appliance. Regularly inspect the supply cord, plug, and actual appliance for any damage. If damaged in any way, immediately cease use of the appliance and call Cuisinart Customer Service at 1-800-726-0190.
15. Refer servicing to qualified personnel.
16. Do not operate any appliance with a damaged cord or plug, or after the appliance malfunctions or has been damaged in any manner. Return appliance to the nearest authorized service facility for examination, repair, or adjustment.
17. Unplug from outlet when not in use and before cleaning. Allow to cool before putting on or taking off parts, and before cleaning the appliance.
18. Do not operate your appliance in an appliance garage or under a wall cabinet. **When storing in an appliance garage, always unplug the unit from the electrical outlet.** Not doing so could create a risk of fire, especially if the appliance touches the walls of the garage or the door touches the unit as it closes.
19. This appliance is not intended for use by persons (including children) with reduced physical, sensory, or mental capabilities, or lack of experience and knowledge, unless they have been given supervision or instruction concerning use of the appliance by a person responsible for their safety.
20. Children should be supervised to ensure that they do not play with the appliance.
21. The heating element surface is subject to residual heat after use.
22. User Maintenance instruction shall warn a user that any other servicing should be performed by an authorized service representative.
23. Scalding may occur if the lid is removed during the brewing cycles.
24. **WARNING:** To avoid the risk of injury, do not open the brew chamber during the brew process.
25. To unplug, grasp the plug and pull from the outlet. Never pull from the power cord.
26. This appliance should not be used by or near children or individuals with certain disabilities .

Save These Instructions For Household Use Only

Warning: Risk of Fire or Electric Shock



The lightning flash with arrowhead symbol within an equilateral triangle is intended to alert the user to the presence of uninsulated dangerous voltage within the product's enclosure that may be of sufficient magnitude to constitute a risk of fire or electric shock to persons.



The exclamation point within an equilateral triangle is intended to alert the user to the presence of important operating and maintenance (servicing) instructions in the literature accompanying the appliance.

Special Safety Instructions

1. Use only cold water in the water reservoir.
Do not use any other liquid.
2. Never use the machine without water in it.
3. Ensure the portafilter holder is firmly secured when using the machine.
4. Never remove the portafilter holder during the brewing operation as the machine is under pressure.
WARNING: To avoid the risk of injury, do not open the brew chamber during the brew process.

NOTE: For safety reasons it is recommended you plug your Cuisinart appliance directly into the power outlet. Use in conjunction with a power strip or extension cord is not recommended.

Special Cord Set Instructions

A short power-supply cord is provided to reduce the risks resulting from becoming entangled in or tripping over a longer cord.

Longer extension cords are available and may be used if care is exercised in their use.

If a long extension cord is used, the marked electrical

rating of the extension cord must be at least as great as the electrical rating of the appliance, and the longer cord should be arranged so that it will not drape over the countertop or tabletop, where it can be pulled on by children or tripped over.

Notice

This appliance has a polarized plug (one blade is wider than the other). To reduce the risk of electric shock, this plug will fit in a polarized outlet only one way. If the plug does not fit fully in the outlet, reverse the plug. If it still does not fit, contact a qualified electrician. Do not modify the plug in any way.

When brewing coffee into a travel mug, you will need to remove the drip tray.

NOTE: There may be water found in the drip tray as a result from normal brewing.

Contents

Important Safeguards	2
Unpacking Instructions	4
The Quest for the Perfect Cup of Espresso.....	5
Features and Benefits.....	6
Getting to Know Your Control Panel.....	7
Accessories	8
Charcoal Water Filter	9
Preparing Your Espresso Machine.....	9
Programming Your Espresso Machine	10
Guide to the Perfect Espresso	11
Cold Extraction	12
Guide to Milk Texturing	12
Using the Hot Water Function	13
Cleaning and Maintenance	14
Warranty	17
Recipes	18

Important Unpacking Instructions

1. Place the box on a large, sturdy, flat surface.
2. Remove literature.
3. Turn the box so that the back side of the box is face down and slide the inner contents out on to a flat surface.
4. After the unit has been removed, place the box out of the way and lift off the top polyfoam insert.
5. Remove the portafilter and the white box labeled Espresso Accessories Box from the polyfoam.
6. Unwrap the portafilter and place to the side.
NOTE: The portafilter is packed with the double shot filter basket in place.
7. Open the Espresso Accessories Box and remove all contents.
NOTE: Accessories packed inside the Frothing Pitcher, Tamper Tool and Single shot Espresso Filter. Steam Wand Cleaning Pin is packed inside the storage tray. See page 8 of the instruction manual for reference and integrated storage instructions.
8. Remove the espresso maker from the polyfoam and remove the polybag covering the machine.
9. Place unit on a flat surface and remove all other packaging materials and tape.
NOTE: Charcoal Water Filter and Filter Holder are stored inside the water tank.
10. Add the filters and coffee scoop in storage tray behind drip tray. See images on page 6 and 8 for reference.

We suggest you save all packing materials in the event that future shipping of the machine is needed. Keep all plastic bags away from children.

KEEP ALL PLASTIC BAGS AWAY FROM CHILDREN.

The Quest for The Perfect Cup of Espresso

It is generally agreed that there are four basic elements critical to the perfect cup:

Element 1: Water

When brewing espresso, make sure the water flows through the filter at the correct pace. The water flow can be adjusted by varying the pressure with which the coffee is tamped (pressed down) in the filter or by altering the grind of the coffee. If the speed of the water flow is too slow, the coffee will be overextracted and will be very dark and bitter, with a spotted and uneven crema (froth) on the top. If the speed of the water flow is too fast, the coffee will be underextracted and the supreme flavor will not develop. The coffee will be diluted and there will be an inadequate amount of crema on the top.

Element 2: Coffee

While the bulk of the liquid is water, all of the flavor should be from the coffee. To achieve the same great quality of coffee you receive at a café, you need to use the same quality beans. If you choose to grind your own beans, buy the beans fresh and whole, only about a two-week supply at a time for maximum freshness. Once the coffee bean is broken, its flavor degrades very quickly. If it is not practical to buy smaller supplies, we recommend you separate larger amounts of beans and store them in airtight containers in a cool, dry area. They should not be kept for longer than 1 month as flavor will diminish. Do not refrigerate or freeze coffee beans.

Element 3: Grind

The grind of the coffee is critical for proper flavor extraction. If using a pre-ground coffee, be sure to purchase an espresso grind that is specifically for espresso/cappuccino machines. If the grind is too fine, overextraction and bitterness will occur with a spotted and uneven crema on the top. If the grind is too coarse, the water will pass through too rapidly, and there will be an inadequate amount of crema on the top of the espresso.

Element 4: Tamping the Coffee Grounds

If you choose to use ground espresso, tamping the coffee is a very important part of the coffee making process. Using the provided tamping tool, tamp (press down) the grounds with moderate pressure. Add more coffee and tamp again if necessary to bring coffee to level. Do not overfill the filter basket. If the coffee is not tamped securely, there is a chance that the water will flow through

the coffee too rapidly and the coffee will be underextracted. If the coffee is tamped too firmly, the water will flow through the coffee too slowly and the coffee will be overextracted and may overflow through the portafilter.

Features and Benefits

- 1. Water Reservoir Access Door**
- 2. Removable 48-ounce Water Reservoir**
Front-loaded for easy filling. Easy-view water level window.
- 3. Charcoal Water Filter and Holder**
- 4. Control Panel**
See detailed illustration on next page.
- 5. Cup-Warming Plate**
Used to warm the espresso cups.
- 6. Bottomless Portafilter**
54mm stainless steel bottomless portafilter.
- 7. Steam & Hot Water Wand**
Steams milk for cappuccinos and lattes or dispenses hot water.
- 8. Group Head/Brew Head**
For easy fit of the portafilter holder. Has two positions, lock and unlock, for ease of cleaning.
- 9. Adjustable Shelf**
Flip-down shelf to accommodate smaller cups.
- 10. Removable Drip Tray**
Removes for easy cleaning and to accommodate up to a 20 oz. travel mug.
- 11. Storage Compartment**
Integrated tray holds accessories when not in use. See next page for details.
- 12. Removable Drip Tray Plate**
- 13. 20 Bar Pump (not shown)**
20 bars of pressure for balanced extraction.

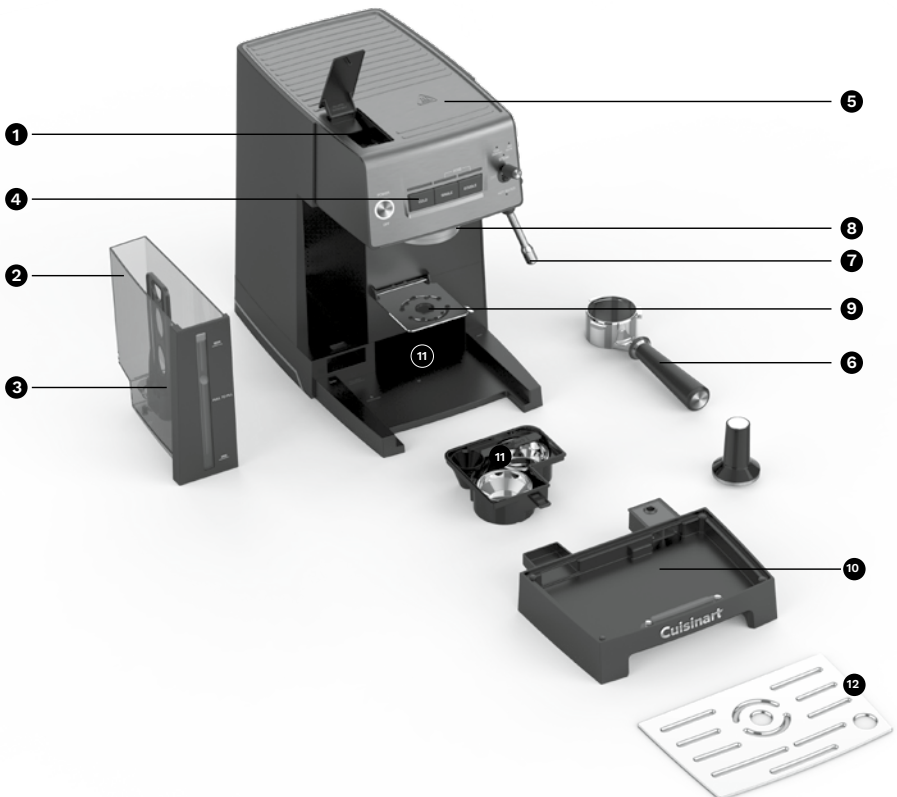

Getting to Know Your Control Panel

1. Power/Off Button

Use to turn the espresso maker on and off.
This button illuminates when pressed.

2. Cold Button

Used to activate cold extraction function.

3. Single Dose Button

Use for a single serving of espresso –
1.0 ounces.

4. Double Dose Button

Use for a double serving of espresso –
2.0 ounces.

5. Clean/Descale Indicator

6. Add Water Indicator

7. Steam or Hot Water Control Switch

Use to activate steam or hot water.

7A. Steam

Use when making cappuccinos and lattes.
Will breathe until ready for use.

7B. Hot Water

Use to dispense hot water.

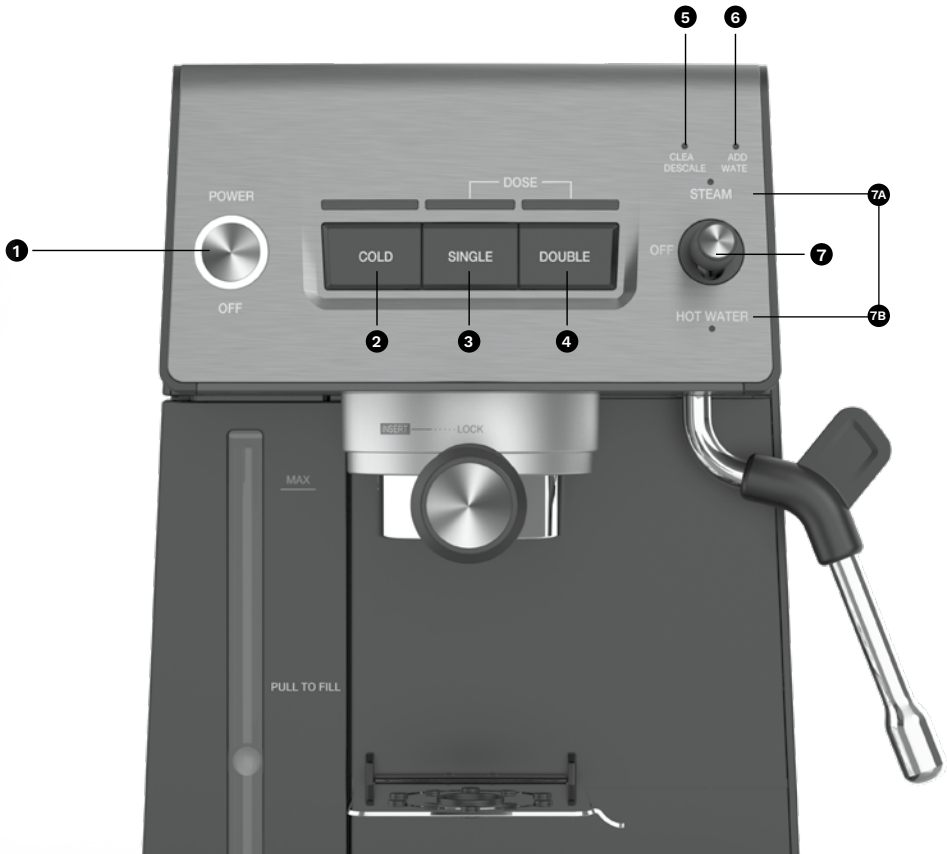

Accessories

1. **Coffee Scoop**
2. **Steam Wand Cleaning Pin**
3. **Tamping Tool**
4. **Single Shot Espresso Filter**
Use the 1-cup filter basket for a single espresso.
5. **Double Shot Espresso Filter**
Use the 2-cup filter basket for a double espresso.

6. **54mm Bottomless Portafilter**
7. **Accessory Storage Tray**
8. **Frothing Pitcher**
9. **Charcoal Water Filter**
10. **Charcoal Water Filter Holder**



Charcoal Water Filter

Inserting the Water Filter

- Remove the filter from polybag and soak it, fully immersed, in cold tap water for 15 minutes.
- Lift the water filter holder out of the water reservoir.
- Press down on the filter compartment and pull toward you to open.
- Place filter into the holder and snap it closed. Be careful – improper placement can tear the filter skin.
- Flush filter by running cold tap water through holes in bottom of compartment for 10 seconds.
- Allow the filter to drain completely.
- Slide the water filter holder back into the channel in the water reservoir, pushing it down to the base of the reservoir.



NOTE: We recommend changing the water filter every 60 days or after 60 uses, and more often if you have hard water.

Replacement filters can be purchased in stores, by calling Cuisinart Customer Service, or at www.cuisinart.com.

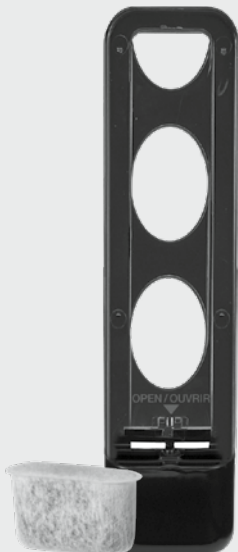

Preparing Your Espresso Machine

Place the espresso machine on a dry, stable countertop or other surface where you will be using the machine.

IMPORTANT: For first-time use or if the machine has not been used for some time, it is important that the machine is rinsed. See instructions outlined below.

Remove the red plug from the back of the water reservoir.

Insert Drip Tray

1. To access the Accessories Storage Compartment, slide the drip tray all the way out of the unit.
2. Remove the desired filter basket from the compartment and replace back into position.
3. Slide drip tray back into position ensuring the drip tray and drip tray plate are securely in place.

Add Water

To fill the espresso machine with water, simply press the reservoir door at the top of the espresso machine, and fill with fresh cold water or filtered water or remove the reservoir by pulling it towards you and replace back into the unit until the reservoir is firmly in place.



NOTE: The unit will not function unless the water reservoir is properly in place and has water in the reservoir.

Run a Rinse Cycle

1. Insert the plug into a power outlet. Press the power button once to turn the espresso machine on. The light around the power button is solid; this is to indicate that your espresso machine is on. The Dose buttons will breathe slowly to indicate that your espresso maker is heating up.



NOTE: Before turning on the espresso machine, ensure that the Steam and Hot Water Control Switch is in the OFF position. If not, the Steam light or Hot Water light will flash until the switch is returned back to the Off position.



2. Make sure the drip tray and drip tray plate are in place.
3. Make sure water has been added to the water reservoir.

NOTE: If the water reservoir is empty, the unit will not function. The ADD WATER indicator will illuminate until the reservoir is filled.

4. Fit the portafilter holder with either the Single or Double Shot Espresso Filter Baskets. Secure the portafilter handle to the brew head.

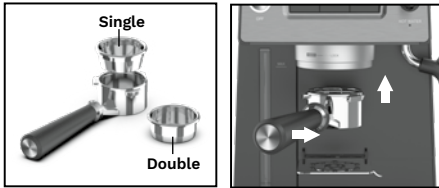

5. Place a sufficiently large container under the bottomless portafilter.
6. Press the SINGLE DOSE button and allow the water to run through for approximately 20 to 25 seconds.

Programming Your Espresso Machine

The Cuisinart Espresso Bar™ Espresso Machine has programming capabilities. Based on café settings, the Single and Double Dose Brew Start Button espresso functions are set at 1.0 and 2.0 oz. However, by following a few simple steps, you can program your perfect serving size down to the ounce. See Default/Programmable Setting chart on page 11 for reference.

Programming Single Espresso

1. Prepare the portafilter holder with the Single Shot Espresso Filter basket and fill with finely ground espresso. Using the tamping tool, tamp the coffee

grounds. Secure the portafilter holder to the brew head.



2. Place a cup under the bottomless portafilter.



3. To begin programming, press and hold the single espresso button for 3 seconds, until the Single Dose light is breathing. The espresso machine will start the espresso pour.

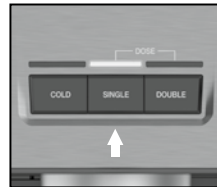

4. Allow the espresso to pour until it reaches the desired level. Once that is reached, stop the espresso pour by releasing the single espresso button. A beep will signify that the new setting for the single espresso operation has been programmed and stored in the machine's memory.
5. The espresso machine will then return to normal operation mode and is ready to make another espresso at the push of a button.

Programming Double Espresso

1. Prepare the portafilter holder with the Double Shot Espresso Filter basket and fill with finely ground coffee. Using the tamping tool, tamp the coffee grounds. Secure the portafilter holder to the brew head.
2. Place a cup under the bottomless portafilter.
3. To begin programming, press and hold the double espresso button for 3 seconds, until the Double Dose light is breathing. The espresso machine will start the espresso pour.

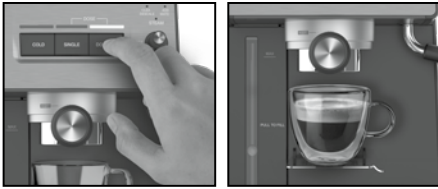

4. Allow the espresso to pour until it reaches the desired level. Once that level is reached, stop the espresso pour by releasing the double espresso button. A beep will signify that the new setting for the double espresso operation has been programmed and stored into the machine's memory.
5. The espresso machine will then return to normal operation mode and is ready to make another espresso at the push of a button.

Resetting the Factory Settings

To revert to the original factory settings:

1. Press and hold down the POWER button and COLD button for approximately 3 seconds or 1 beep sound. The POWER light, COLD light, and DOSE light will flash 1 time.
2. The espresso machine has now returned to the original factory settings. The default programming for each function will be used for the next brew. See chart below for default settings by function for reference.



Defaults for each function are as follows:

	Default Program Settings	Amount	Programmable Range
Brew Volume	Single	1.0 oz.	1.0 oz. - 2.7 oz.
	Double	2.0 oz.	1.7 oz. - 4.0 oz.

3. The espresso machine will then return to normal operation mode and is ready to make another espresso at the push of a button.

Guide to the Perfect Espresso

1. Placing cups on the warming plate before brewing will help preserve the crema of the espresso. Remove cups when ready to brew.
2. Select the appropriate filter basket and insert it into portafilter. Use the Single Shot filter basket for a single espresso, and the Double Shot filter basket for a double espresso.

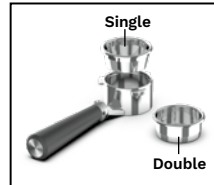

3. Using the coffee scoop, spoon finely ground coffee in the filter basket holder. Use 2 scoops for single espresso cup and 3 scoops for double espresso.

TIP: If portafilter seems to be getting overfilled, gently tap the portafilter on counter to level the grounds.



4. Using the tamping tool, apply a moderate packing pressure.



IMPORTANT: Be sure not to overfill the filter basket with coffee as this can cause the portafilter holder to overflow.

Single Dose: recommended 9-11g (min. 6g)

Double Dose: recommended 17-19g (min. 12g)

NOTE: Check to see that the espresso machine is ready for use. Remember that if the power light is solid and the Cold, Single & Double LEDs are solid, the espresso machine is on and is heating up and ready to brew coffee.

- Brush any excess coffee grounds from around the edge of the filter basket.
- Secure the portafilter holder to the brew head.

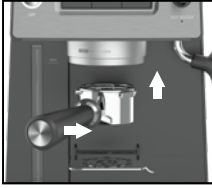

- Place a cup under the portafilter.
- Press the Single or Double Dose Brew Start button to begin brewing.

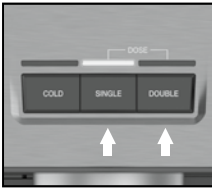

- Check the espresso pour. The ideal pour is dark and caramel with reddish reflections.
- Serve espresso immediately.
- Remove the portafilter handle from the brew head.
- Discard the used coffee grounds.

Cold Extraction

Cold extraction pulls a heatless shot that uses ambient temperature water to extract the full flavor of the coffee. Convenient for on-the-go lattes or cold coffee drinks.

- Follow steps 3-7 under Guide to the Perfect Espresso above on page 11.
- Press Cold button then the Single and Double will flash until desired size is chosen.

NOTE: Cold Single Brew is 3.45 ounces and Double Brew is 5 ounces.

- For on-the-go drinks, remove the drip tray and place your travel mug under brew head instead of the a cup.

Sleep Mode

After 30 minutes of nonuse, the espresso machine will automatically power off.

Guide to Milk Texturing

Milk texturing is the steaming of milk. The steam does two things: It heats the milk and mixes air with the milk to form a foamy texture. As with learning to make an espresso, perfecting the art of milk texturing takes time and practice.

- Determine how much milk is needed based on the number of cups being made.

TIP: Keep in mind that the volume of milk will increase during the texturing.

- Pour cold refrigerated milk into the stainless frothing pitcher, approximately half full, but not over the MAX mark.
- Move the Steam/Hot Water switch up to Steam position. The Steam light will be breathing.
- Purge the steam wand of any water with the steam wand positioned over the drip tray.
- When the Steam light becomes solid, the steam function is activated. Once any water has been purged, stop the steam by turning the Steam/Hot Water switch to the OFF position.
- Swing the steam wand to the side of the espresso machine.



- Place the steam wand into the milk so that the nozzle is about a half-inch below the surface and activate the steam function by turning the Steam/Hot Water control switch to the Steam position.
- Angle the pitcher so that the steam wand is resting on the spout of the pitcher, and lower the pitcher until the tip of the steam nozzle is just below the surface of the milk. This will start to create a whirlpool action in the milk.

NOTE: Do not allow the steam to spurt unevenly or it will create aerated froth/large bubbles. If this is happening, raise the pitcher so that the steam nozzle is lowered farther into the milk.

- As the steam heats and textures the milk, the level of the milk in the pitcher will begin to rise. As this happens, follow the level of the milk by lowering the pitcher, always keeping the tip of the steam nozzle just below the surface.
- Once the foam is created, raise the pitcher until the steam nozzle is in the center of the milk.

TIP: The amount of foam required will vary depending on the drinks being made. For example, a cappuccino requires more foam than a latte.

- Stop the steam immediately by moving the Steam/Hot Water control switch to the OFF position.

IMPORTANT: Do not boil the milk.

- Remove the pitcher, immediately wipe the steam nozzle and wand with a clean damp cloth, and purge a small amount of steam.



Using the Hot Water Function

- Place the cup or container under the steam/hot water wand and activate the hot water function by moving the Steam/Hot Water control switch to the Hot Water position.
- Once you have dispensed the required amount



of
hot

water into the cup or container, stop the hot water by switching the Steam/Hot Water control switch to the OFF position. The Hot Water feature will be stopped after 1 minute.

- Remove the cup or container and swing the Steam/Hot Water wand over the drip tray to catch any drips of water.

Cleaning and Maintenance

Always turn the espresso maker off and remove the plug from the electrical outlet before cleaning.

Never immerse unit in water or other liquid. To clean, simply wipe with a clean damp cloth and dry before storing.

Cleaning the Filters, Portafilter Holder, and Brew Head

- The stainless steel filters and portafilter holder should be rinsed under water immediately after use to remove all coffee particles. You may also use the gray cleaning pin (smaller pin) to clear the opening.
- Periodically run water through the machine with the portafilter holder in place, but without any ground coffee, to rinse out any lingering coffee particles.
- The inside of the brew head should be wiped with a damp cloth to remove any coffee particles.

Cleaning the Outer Housing/Cup Warming Plate

- The outer housing and cup warming plate can be cleaned with a soft, damp cloth. Do not use any scouring agents or harsh cleaners.

Cleaning the Drip Tray Plate

- The drip tray plate should be removed, emptied, and cleaned frequently, particularly when the drip tray is full.
- The drip tray plate can be washed in warm soapy water and rinsed thoroughly. Use a nonabrasive washing liquid (do not use abrasive cleaners, pads or cloths, which can scratch the surface).

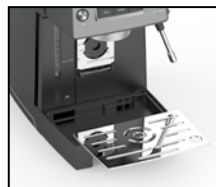

Cleaning the Drip Tray

- The drip tray can be removed after the drip tray plate is removed and then cleaned with a soft, damp cloth (do not use any scouring agents or harsh cleaners).

NOTE: Do not clean any parts or accessories in the dishwasher.

Cleaning the Steam Wand

- The steam wand should always be cleaned after steaming milk.
- Wipe the steam wand with a damp cloth, then swing the steam wand back into the drip tray. Momentarily switch the Steam/Hot Water control switch to the hot water position. This will release any remaining milk from inside the steam wand.



- Make sure the Steam/Hot Water control switch is in the OFF position. Press the power button off, unplug the power cord, and allow the machine to cool.
- If the steam wand remains blocked, use the Steam Wand Cleaning Pin to clear the opening.

Maintenance: Any other servicing should be performed by an authorized service representative.



Decalcification

Decalcification refers to the removal of calcium deposits that form over time on the metal parts of the coffeemaker.

For best performance from your espresso maker, decalcify the unit from time to time.

The frequency depends on the hardness of your tap water and how often you use the coffeemaker.

The machine will remind to clean by switching on the DESCALE light,.

To run a Clean/Descal cycle, follow the instructions below.

1. Place 2 large 1.5L (50 oz.) containers under the brew head and steam wand.
2. Fill the water reservoir to capacity with a mixture of one-third white vinegar and two-thirds water or with the mixture of 1 descale tablet and water at max level.
3. Press and hold COLD & SINGLE button for 3 seconds, then the CLEAN DESCALE LED will flash.
4. Move the Steam/Hot Water switch down to the Hot Water position. The CLEAN DESCALE light will be breathe. The cleaning program has started.
 - Descaling: Hot water will flow from the steam wand, then switch to the brew head automatically. When water tank is empty, the CLEAN DESCALE light will flash and ADD WATER light will go on. Fill the water tank with water to max level. Empty the drip tray and 2 large containers and replace them in the unit. Move the Steam/Hot Water switch up to the Steam position and the CLEAN DESCALE light will be on.
 - Cleaning: Hot water will flow from the brew head, then switch to the steam wand automatically. When water tank is empty, the CLEAN DESCALE light will turn off. The ADD WATER light will go on, STEAM light will be flashing, and the Descale is finished.

Warranty

Subject to the exclusions and limitations contained herein, Conair LLC dba Cuisinart ("Cuisinart") warrants that the Cuisinart Espresso Bar™ Espresso Machine ("Product") will be free from material defects in materials and workmanship under normal home use conditions for a period of three (3) years beginning on the date the Product was purchased in its original, sealed packaging, unless otherwise specified in this Limited Warranty. This Limited Warranty is only for U.S. consumers (defined herein as purchasers at retail for personal, family, or household use) who originally purchase the Product from Cuisinart or an authorized Cuisinart® reseller (if you are unsure whether a retailer or other point of sale is an authorized or unauthorized Cuisinart reseller, contact Cuisinart).

This Limited Warranty does NOT cover:

- Normal wear and tear;
- Any Product purchased by commercial purchasers or for commercial or nonhousehold uses;
- Accessories, parts, or software added to the Product after the system is shipped from Cuisinart;
- Any costs associated with the replacement or repair of the Product, including labor, installation, or other costs incurred by you without prior Cuisinart approval;
- Damage to the Product, defective conditions, or nonconformities due to: (1) external causes, including shipping, accidents, problems with electrical power (Product designed only for use with 120-volt outlets), abnormal conditions (such as mechanical or environmental); (2) usage not in accordance with Product instructions; (3) misuse, neglect, unauthorized alteration, unauthorized repair; and (4) acts of god or other events beyond Cuisinart's control;
- Though necessary repairs and maintenance might be performed by any company, damage caused by you or any nonauthorized third party may void this Limited Warranty;
- Damage caused by accessories or replacement parts not specifically authorized by Cuisinart may void this Limited Warranty; and
- Any Product where the original Product identification markings (trademark or serial number) have been removed, altered, or obliterated from the Product.

It is recommended that you visit the website <https://cuisinart.registria.com> for a fast, efficient way to complete your product registration. However, product registration does not eliminate the need for the consumer to maintain the original proof of purchase in order to obtain the warranty benefits. In the event that you do not have proof of purchase date, the

purchase date for purposes of this Limited Warranty will be the date of manufacture.

HASSLE-FREE WARRANTY

If the Product that is the subject of this Limited Warranty fails during the warranty period for reasons covered by this Limited Warranty, Cuisinart will, at its option, repair the Product, replace the Product with another identical or reasonably equivalent product, or if Cuisinart is unable to repair or replace the Product, refund the purchase price, less the amount directly attributable to the consumer's prior usage of the Product. To obtain a return shipping label, email us at <https://www.cuisinart.com/customer-care/product-assistance/product-inquiry/>, or call our Consumer Service Center toll-free at **1-800-726-0190** to speak with a representative.

Upon receipt of the Product, Cuisinart will inspect the Product and, if required under this Limited Warranty, attempt to repair, replace, or refund the Product within thirty (30) days. However, there may be delays beyond Cuisinart's control, in which case that time period may be extended as reasonably necessary.

IMPORTANT: If the nonconforming Product is to be serviced by someone other than Cuisinart's Authorized Service Center, please remind the servicer to call our Consumer Service Center at **1-800-726-0190** to ensure that the problem is properly diagnosed, the Product is serviced with the correct parts, and the product is still under warranty.

CALIFORNIA RESIDENTS ONLY

The three (3) year Limited Warranty period begins on the date the Product was delivered, which may be different than the date the Product was purchased. California residents also have the option of obtaining the benefits of this Limited Warranty by bringing the Product to (A) the store where it was purchased or (B) another retail store that sells Cuisinart products of the same type. The retail store shall then, according to its preference, either repair the Product, refer the consumer to an independent repair facility, replace the Product with another identical or reasonably equivalent product, or refund the purchase price less the amount directly attributable to the consumer's prior usage of the Product. California residents may also, according to their preference, return nonconforming products directly to Cuisinart for repair or, if necessary, replacement with another identical or reasonably equivalent product by calling our Consumer Service Center toll-free at **1-800-726-0190**. Cuisinart will be responsible for the cost of such repair, replacement, and/or shipping and handling for such nonconforming products under warranty.

THIS LIMITED WARRANTY GIVES YOU SPECIFIC LEGAL RIGHTS, AND YOU MAY ALSO HAVE OTHER RIGHTS THAT VARY FROM STATE TO STATE OR BY JURISDICTION. IN THE EVENT THIS LIMITED WARRANTY IS BREACHED, YOU MAY HAVE CLAIMS FOR REPLACEMENT, DAMAGES, OR OTHER PENALTIES.

LIMITATIONS OF LIABILITY/ADDITIONAL LIMITATIONS AND EXCLUSIONS

ALL EXPRESS AND IMPLIED WARRANTIES ARE LIMITED IN DURATION TO THE LIMITED WARRANTY PERIOD. NO WARRANTIES APPLY AFTER THAT PERIOD. SOME STATES DO NOT ALLOW LIMITATIONS ON HOW LONG AN IMPLIED WARRANTY LASTS, SO THIS LIMITATION MAY NOT APPLY TO YOU. CUISINART'S RESPONSIBILITY UNDER THIS OR ANY OTHER WARRANTY, IMPLIED OR EXPRESS, IS LIMITED TO REPAIR, REPLACEMENT, OR REFUND, AS SET FORTH ABOVE. THESE REMEDIES ARE THE SOLE AND EXCLUSIVE REMEDIES FOR ANY BREACH OF WARRANTY. TO THE MAXIMUM EXTENT PERMITTED BY LAW, CUISINART IS NOT RESPONSIBLE FOR ANY DIRECT, INDIRECT, SPECIAL, INCIDENTAL, OR CONSEQUENTIAL DAMAGES RESULTING FROM ANY BREACH OF WARRANTY OR UNDER ANY OTHER LEGAL THEORY (INCLUDING, BUT NOT LIMITED TO, LOST PROFITS, DOWNTIME, GOODWILL, DAMAGE TO OR REPLACEMENT OF EQUIPMENT AND PROPERTY, AND ANY COSTS OF RECOVERING, REPROGRAMMING, OR REPRODUCING ANY PROGRAM OR DATA STORED IN OR USED WITH A SYSTEM CONTAINING THE PRODUCT), EVEN IF CUISINART HAS BEEN ADVISED OF THE POSSIBILITY OF SUCH DAMAGES. SOME STATES DO NOT ALLOW THE EXCLUSION OR LIMITATION OF INCIDENTAL OR CONSEQUENTIAL DAMAGES, SO THE ABOVE LIMITATIONS OR EXCLUSIONS MAY NOT APPLY TO YOU. ALL EXPRESS AND IMPLIED WARRANTIES ARE LIMITED IN DURATION TO THE LIMITED WARRANTY PERIOD. NO WARRANTIES APPLY AFTER THAT PERIOD. SOME STATES (OR JURISDICTIONS) DO NOT ALLOW LIMITATIONS ON HOW LONG AN IMPLIED WARRANTY LASTS, SO THIS LIMITATION MAY NOT APPLY TO YOU.

This Limited Warranty is issued by:

Conair LLC
1 Cummings Point Road
Stamford, CT 06902
1-800-726-0190

Recipes

Americano	17
Macchiato	17
Cappuccino	17
Café Latte	18
Flat White	18
Cortado.....	18
Café au Lait	18
Autumn Spice Latte.....	18
Salted Caramel Latte	19
Golden Latte	19
Café con Leche.....	19
Hazelnut Mocha Latte.....	20
Iced Brown Sugar & Oat Shaken Espresso	20
Espresso Tonic	20
Vietnamese Iced Latte.....	20
Mexican Espresso Martini	20
Irish Espresso.....	21
Espresso Mudslide.....	21
Affogato.....	21
Espresso Gelato.....	21
Tiramisu	22

Americano

Simply stated, an Americano is an espresso with extra hot water. It's a great halfway point between the assertive flavor of an espresso and a full cup of coffee.

Makes 1 serving

**Ground espresso for a double shot
2/3 to 3/4 cup hot water**

1. Brew a double espresso into a heatproof mug.
2. Select Hot Water and, using the steam wand, brew hot water on top of the espresso.
3. Serve immediately.

Macchiato

A macchiato is a smaller espresso drink topped with a little bit of foamed milk. There are many interpretations around the world, but here at Cuisinart, we are staying traditional, starting with the perfect espresso.

Makes 1 serving

**Ground espresso for a single shot
1/4 cup milk (dairy or nondairy)**

1. Brew a single espresso into a heatproof — preferably demitasse — cup.
2. Put the milk into the frothing pitcher. Using the steaming wand, steam the milk until the foam has formed and you can feel that the milk is quite hot. Tap the pitcher a few times to remove any larger bubbles.
3. Spoon 1 tablespoon of the frothed milk on the espresso.
4. Serve immediately.

Cappuccino

Traditionally, a cappuccino is made by layering equal parts espresso, steamed milk, and foam.

Makes 1 serving

**Ground espresso for a single shot
1/3 cup milk (dairy or nondairy)**

1. Brew a double espresso into a heatproof mug.
2. Put the milk into the frothing pitcher. Using the steaming wand, steam the milk until the foam has reached two-thirds of the way up the pitcher and you can feel that the milk is quite hot. Tap the pitcher a few times to remove any larger bubbles.

3. Slowly pour about 3 ounces of the steamed milk into the mug with the espresso and then spoon 3 to 4 tablespoons of frothed milk on top.
4. Serve immediately.

Café Latte

The classic coffee shop beverage made simple at home — just steam your milk, pour over your freshly brewed espresso, and top with a thin layer of foam.

Makes 1 serving

Ground espresso for a double shot cup milk (dairy or nondairy)
½

1. Brew a double espresso into a heatproof mug.
2. Put the milk into the frothing pitcher. Using the steaming wand, steam the milk until the foam has almost reached the top of the pitcher and you can feel that the milk is quite hot. Tap the pitcher a few times to remove any larger bubbles.
3. Slowly pour the steamed milk into the mug with the espresso.
4. Serve immediately.

Flat White

A simple way to describe this increasingly popular coffee shop drink would be “a small strong latte.” It typically has a higher proportion of espresso to milk and slightly less foam than a latte.

Makes 1 serving

Ground espresso for a double shot cup milk (dairy or nondairy)
¼

1. Brew a double espresso into a heatproof mug.
2. Put the milk into the frothing pitcher. Using the steaming wand, steam the milk until the foam has reached two-thirds of the way up the pitcher and you can feel that the milk is quite hot. Tap the pitcher a few times to remove any larger bubbles.
3. Slowly pour a small amount of the steamed milk, about half the volume of the espresso, into the mug with the espresso, holding back the foam with a spoon. Top with a very thin layer of foam.
4. Serve immediately.

Cortado

A cortado is similar to a latte, but instead of being heavy on milk, it uses equal parts espresso and milk and has no foam on top.

Makes 1 serving

Ground espresso for a single shot cup milk (dairy or nondairy)
¼

1. Brew a single espresso into a small heatproof cup.
2. Put the milk into the frothing pitcher. Using the steaming wand, steam the milk until the foam has almost reached the top of the pitcher and you can feel that the milk is quite hot. Tap the pitcher a few times to remove any larger bubbles.
3. Slowly pour ½ to 2 ounces of the steamed milk into the mug with the espresso.
4. Serve immediately.

Café au Lait

Translated from French as “coffee with milk,” this simple beverage calls for equal parts coffee and steamed milk. Here, we use espresso in place of drip coffee to give some extra flavor.

Makes 1 serving

Ground espresso for a double shot cup milk
½

1. Brew a double espresso into a heatproof mug.
2. Put the milk into the frothing pitcher. Using the steaming wand, steam the milk until the foam has almost reached the top of the pitcher and you can feel that the milk is quite hot. Tap the pitcher a few times to remove any larger bubbles.
3. Slowly pour all of the milk, holding back the foam, into the mug with the espresso.
4. Serve immediately.

Autumn Spice Latte

A warm cup of this latte will get you in the fall mood any time of the year.

Makes 1 latte

Autumn Spice Simple Syrup:

2 cinnamon sticks
1 star anise pod
3 cardamom pods
 ½ teaspoon whole cloves
 ½ teaspoon black peppercorns
1 ½-inch piece fresh gingerroot, sliced

- ½ cup water
- ½ cup granulated sugar

Latte:

- 4 ounces milk
- 2 tablespoons Autumn Spice Simple Syrup (see above)

1. Combine the syrup ingredients in a small saucepan. Set over medium-low heat. Bring to a slight simmer, and cook until the sugar has dissolved. Remove from the heat and allow to steep for 30 minutes. Strain the syrup through a fine-mesh strainer into an airtight container; discard the solids. Chill completely prior to using. Note: This syrup can be prepared in advance and stored in an airtight jar for up to 2 weeks.
2. Brew the espresso for a single shot.
3. Put the milk and the 2 tablespoons syrup into the frothing pitcher. Using the steaming wand, steam the milk mixture until the foam has almost reached the top of the pitcher and you can feel that the milk is quite hot. Tap the pitcher a few times to remove any larger bubbles.
4. Slowly pour the steamed milk mixture into the mug with the espresso.
5. Serve immediately.

Salted Caramel Latte

A sweet treat that tastes like it came from the hands of a professional barista.

Makes 1 serving

- 1 tablespoon caramel sauce, plus more for drizzling (optional)
- Ground espresso for a single shot
- Pinch sea salt
- ½ cup milk (dairy or nondairy)

1. Put 1 tablespoon of the caramel sauce into a heatproof mug. Brew a single espresso into the mug with the caramel. Sprinkle with sea salt.
2. Put the milk into the frothing pitcher. Using the steaming wand, steam the milk until the foam has almost reached the top of the pitcher and you can feel that the milk is quite hot. Tap the pitcher a few times to remove any larger bubbles.
3. Slowly pour the steamed milk into the mug with the espresso.
4. Drizzle with additional caramel sauce, if desired.
5. Serve immediately.

Golden Milk Latte

There are many benefits to turmeric, and there's no better way to have it than in a warm latte.

Makes 1 serving

- Ground espresso for a single shot
- ½ cup milk (dairy or nondairy)
- 1 teaspoon honey
- ¼ teaspoon pure vanilla extract
- ½ teaspoon ground turmeric
- ¼ teaspoon ground cinnamon
- ¼ teaspoon ground ginger
- Pinch ground cardamom
- Pinch freshly ground black pepper

1. Brew a single espresso into a heatproof mug.
2. Put the milk, honey, vanilla, and spices into the frothing pitcher. Using the steaming wand, steam the milk until the foam has almost reached the top of the pitcher and you can feel that the milk is quite hot. Tap the pitcher a few times to remove any larger bubbles.
3. Slowly pour the steamed milk mixture into the mug with the espresso.
4. Serve immediately.

Café con Leche

Start your morning off right with this traditional Spanish-style espresso drink.

Makes 1 serving

- Ground espresso for a double shot
- ½ cup whole milk
- 1 teaspoon granulated sugar (optional or to taste)

1. Brew a double espresso into a heatproof mug.
2. Put the milk into the frothing pitcher. Using the steaming wand, steam the milk until the foam has almost reached two-thirds of the way up the pitcher and you can feel that the milk is quite hot. Tap the pitcher a few times to remove any larger bubbles.
3. Slowly pour the steamed milk, holding back the foam, into the mug with the espresso. Sweeten to taste.
4. Serve immediately.

Hazelnut Mocha Latte

Start your morning with a little indulgence.

Makes 1 latte

½ cup milk (dairy or nondairy)
1 tablespoon chocolate hazelnut spread
Ground espresso for a double shot

1. In a small bowl, whisk together the milk and chocolate hazelnut spread. Set aside.
2. Brew a double espresso into a heatproof mug.
3. Put the chocolate hazelnut milk into the frothing pitcher. Using the steaming wand, steam the milk until the foam has almost reached the top of the pitcher and you can feel that the milk is quite hot. Tap the pitcher a few times to remove any larger bubbles.
4. Slowly pour the steamed milk into the mug.
5. Serve immediately.

Iced Brown Sugar & Oat Shaken Espresso

Shaking this nondairy iced espresso creates a perfectly chilled and frothy refreshment.

Makes 1 serving

Brown Sugar Simple Syrup:

1 cup packed light brown sugar
1 cup (8 ounces) water

Shaken espresso:

Finely ground espresso for a double shot
1½ cups ice
½ cup unsweetened oat milk
2 tablespoons Brown Sugar Simple Syrup

1. To make the simple syrup, combine the sugar and water in a small saucepan over medium heat. Heat until the sugar has fully dissolved. Remove from the heat and let cool completely before using.
2. To make the iced espresso, brew a double espresso using the Cold Extraction setting.
3. Fill a mason jar or cocktail shaker with ice. Pour the espresso, oat milk, and simple syrup over the ice. Secure the lid of the mason jar or cocktail shaker, and vigorously shake until the outside is extremely cold, about 20 seconds.
4. To serve, pour over ice and finish with a pinch of cinnamon.
5. Serve immediately.

Espresso Tonic

Swap out gin for espresso for a carbonated drink that is both refreshing and buzzy. Experiment with flavored simple syrups and garnishes to mix it up!

Makes 1 serving

Ground espresso for a double shot
1 teaspoon simple syrup (optional or to taste)
1 to 2 dashes aromatic bitters (such as Angostura)
5 ounces tonic water
Orange or lemon twist, for garnish

1. Using the Cold Extraction setting, brew a double espresso into a small cup.
2. Fill a highball glass with ice. Add the simple syrup (if using), bitters, and tonic water, and stir. Gently pour in the cooled espresso. Drop an orange or lemon twist into the glass to garnish.
3. Serve immediately.

Vietnamese Iced Latte

Sweetened condensed milk provides a pleasant sweetness to the espresso in this iced beverage.

Makes 1 iced latte

2 tablespoons sweetened condensed milk
Ground espresso for 2 double shots
2 cups ice

1. Put the sweetened condensed milk into a mug or glass.
2. Brew two double espressos over the condensed milk using the Cold Extraction setting. When brewing is complete, stir until combined.
3. Fill a highball glass with ice. Pour the latte over the ice.
4. Serve immediately.

Mexican Espresso Martini

Substituting a good-quality reposado tequila for vodka supplies some caramel notes to this buzzworthy drink.

Makes 2 servings

2 ounces brewed espresso
2 ounces reposado tequila
3 ounces rum-based coffee liqueur
Ice

1. Put the espresso, tequila, and coffee liqueur into a

cocktail shaker filled with ice.

2. Shake vigorously and pour through a strainer* over two chilled martini glasses.
3. Serve immediately.

*A Hawthorne strainer is best if available.

Irish Espresso

With just the right amount of sweetness, this classic hot cocktail is a nice substitute for dessert at the end of a meal.

Makes 1 serving

- 1½ ounces heavy cream
- 1 tablespoon granulated sugar
- ½ teaspoon pure vanilla extract
- Pinch kosher salt
- 1 ounce Irish whiskey
- Ground espresso for a double shot

1. Put the cream, sugar, vanilla, and salt in a mixing bowl and whisk to soft peaks by hand with a whisk or with a hand mixer.
2. Put the whiskey into a mug, and then brew a double shot of espresso into the whiskey.
3. Top with the whipped cream.
4. Serve immediately.

Espresso Mudslide

Espresso gives this sweet cocktail a nice jolt. Blending this cocktail with vanilla ice cream makes a decadent adult milkshake.

Makes 2 servings

- Chocolate syrup, as needed
- Ice
- 3 ounces brewed espresso
- 2 ounces Irish cream liqueur
- 1 ounce vodka
- 1 ounce coffee liqueur

1. Drizzle chocolate syrup inside the walls of two glasses and fill with ice.
2. Put the espresso, Irish cream, vodka, and coffee liqueur into a cocktail shaker filled with ice.
3. Shake vigorously and pour through a strainer* into the prepared glasses.
4. Serve immediately.

*A Hawthorne strainer is best if available.

Affogato

Scoop your gelato in advance and save in the freezer until ready to serve.

Makes 1 serving

- Ground espresso for a double shot
- scoop vanilla gelato or ice cream

1. Brew a single espresso into a small heatproof cup.
2. Put the gelato into a small serving dish, and then pour the hot espresso over the gelato.
3. Serve immediately.

Espresso Gelato

For an extra jolt, add some chopped dark chocolate-covered espresso beans toward the end of freezing.

Makes about 4 cups (eight ½-cup servings)

- 2 cups whole milk, divided
- 1 cup heavy cream
- 1 cup brewed espresso
- 1 cup granulated sugar
- 2 tablespoons cornstarch
- Pinch sea salt
- 1 tablespoon liquid pectin

1. In a medium saucepan, combine 1½ cups of the milk and the cream. Set over medium/medium-low heat and bring to a simmer.
2. While the milk-cream mixture is heating, put the espresso, the remaining ½ cup milk, the sugar, cornstarch, and salt into a small or medium mixing bowl. Whisk to combine.
3. When the milk-cream mixture comes to a simmer, add the espresso mixture, and stir until combined. While cooking over medium/medium-low heat, stir continuously until the mixture comes to a boil and thickens enough to coat the back of a spoon, about 15 minutes.
4. Remove the pan from the heat, stir in the pectin, strain, and then let cool to room temperature. Cover and refrigerate for a minimum of 2 hours, or overnight.
5. Whisk the gelato base, and then freeze in a Cuisinart Ice Cream Maker. Churn until thickened, about 40 minutes. The gelato will have a soft, creamy texture. Serve or store in an airtight container in the freezer.

Tiramisu

Whether you call it “classic” or “retro,” you can never go wrong with tiramisu. It is creamy, deliciously intense, and a great ending to a meal any time of year. Here, we cut some corners so you can still impress your guests with a bit less work!

Makes 9 servings

- 1 container (8 ounces) mascarpone cheese, room temperature**
- 1 cup heavy cream, chilled**
- ¼ cup plus 2 tablespoons confectioners’ sugar**
- 2 tablespoons plus 1 teaspoon dark rum, divided**
- 1½ cups brewed espresso**
- 28 Savoiri (crisp Italian ladyfingers)**
- ¼ cup unsweetened cocoa powder, for garnish**

1. Put the mascarpone into a medium bowl. Using a hand mixer, beat until lightened and lightly whipped.
2. In a separate bowl, whip the cream to soft peaks, gradually adding the confectioners’ sugar while whipping the cream. Add 1 teaspoon of the rum to the whipped cream and whisk a few times to incorporate.
3. Gently fold the whipped cream into the mascarpone, one-third at a time, until completely incorporated. Reserve.
4. Using the Cold Extraction setting, brew three double espressos into a large liquid measuring cup. Add the remaining 2 tablespoons of rum.
5. Working with one cookie at a time, dip the ladyfingers into the espresso mixture, soaking each side for a few seconds, and then transfer to a 9-inch square baking pan. Repeat with 13 more of the ladyfingers, arranging in the bottom of the pan to cover the entire surface. It should be a tight fit.
6. Spread half of the mascarpone cream evenly over the ladyfingers, covering the entire surface. Dip the remaining ladyfingers and arrange in an even layer over the cream. Spread the remaining mascarpone mixture evenly over the ladyfingers. Cover with plastic wrap and chill for at least 6 hours.
7. Remove the plastic, and then sift the cocoa powder over the top of the tiramisu. Serve immediately.

©2025 Cuisinart
Glendale, AZ 85307

Printed in China

24CE93197

IB-18597