

28-11-2019

Modèle / Model:

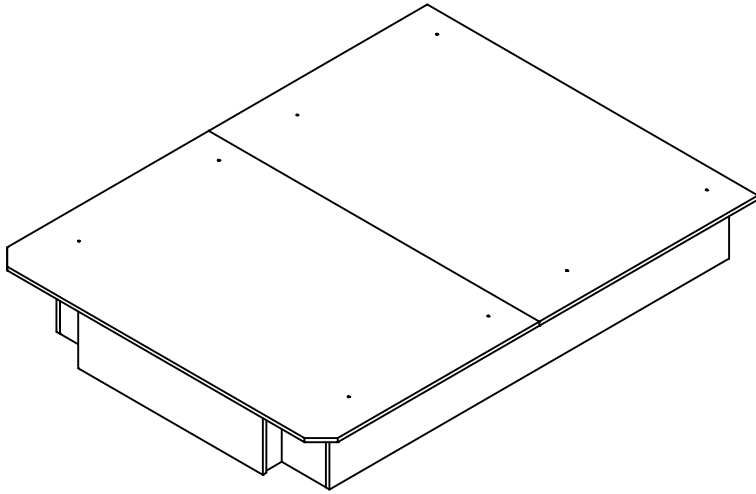







**966-60**

Plan d'assemblage  
Assembly instruction

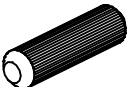

Fabriqué et imprimé au Canada/Made and printed in Canada

1/4

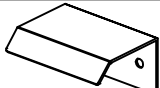
Code	Quincaillerie / Hardware	Qté / Qty
#001	VIS DIRECTA DIRECTA SCREW 	8
#002	VIS CONFIRMAT CONFIRMAT SCREW 	8
#973	FERRURE D'ASSEMBLAGE KNOCK DOWN FITTING 	16
	DOUILLE DOWEL 	
#031	GOUJON DE BOIS WOODEN DOWEL 	12
#902	PATTES À CLOU GLIDE 	12
#003	VIS À COULISSE RAIL SCREW 	6
#775	VIS 6 x 5/8" TÊTE PLATE 6 X 5/8" FLAT HEAD SCREW 	2
#887	POIGNÉE HANDLE 	1

Étape / Step #1

LISTE DES PIÈCES / PART LIST

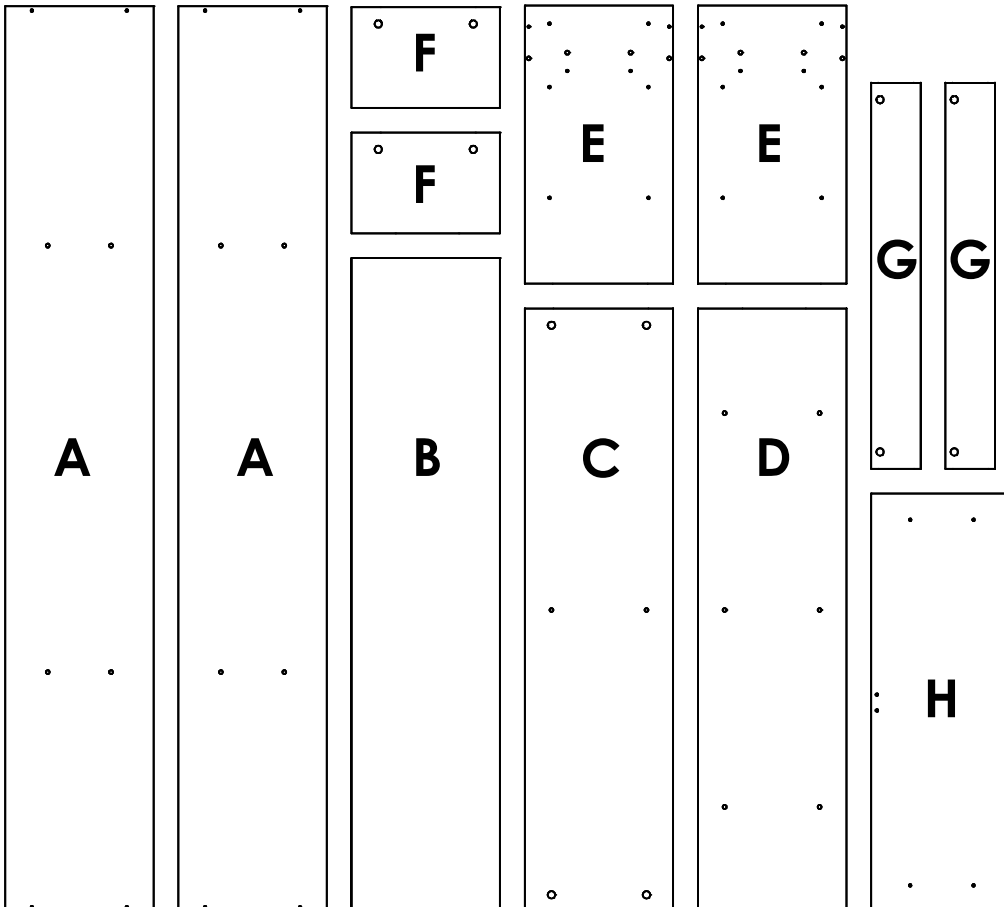

Inclus dans la  
boîte 866-2/3.

Included in the  
box 866-2/3.

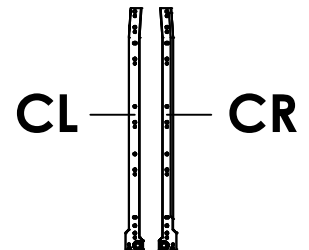

Étape / Step #2

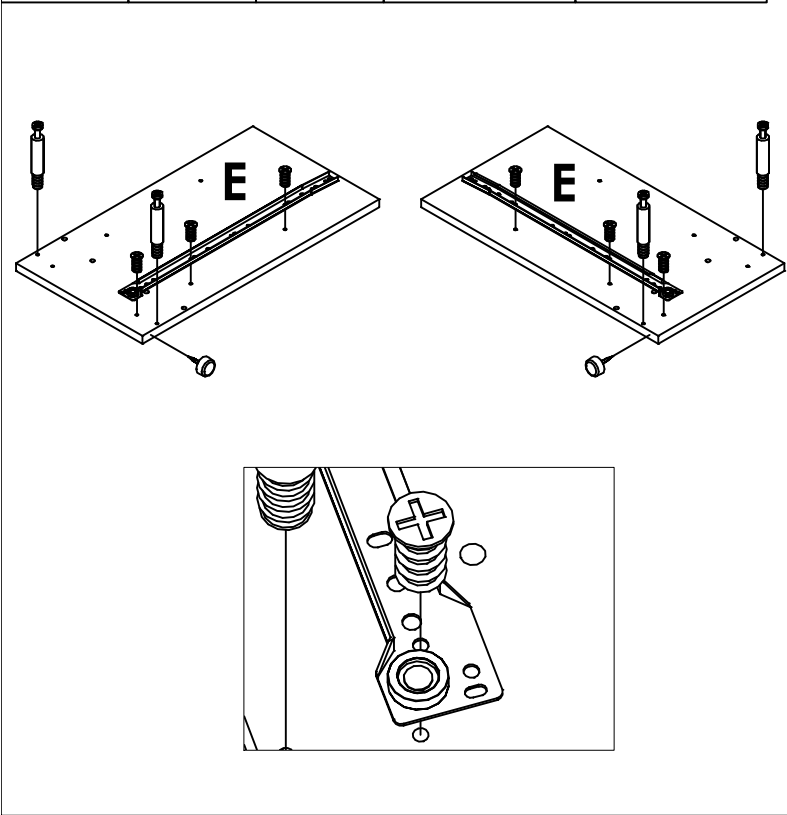
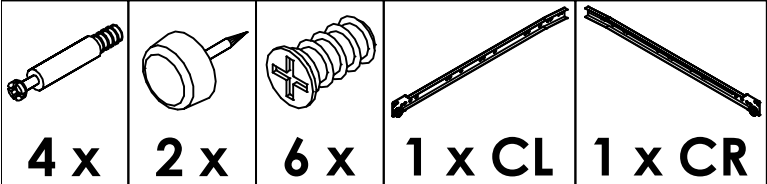

Étape / Step #3

NOTE: ASSUREZ VOUS QUE LES TROUS SONT LIBRES DE POUSSIÈRE / BE SURE THAT THE HOLES ARE FREE OF DUST

2 / 4

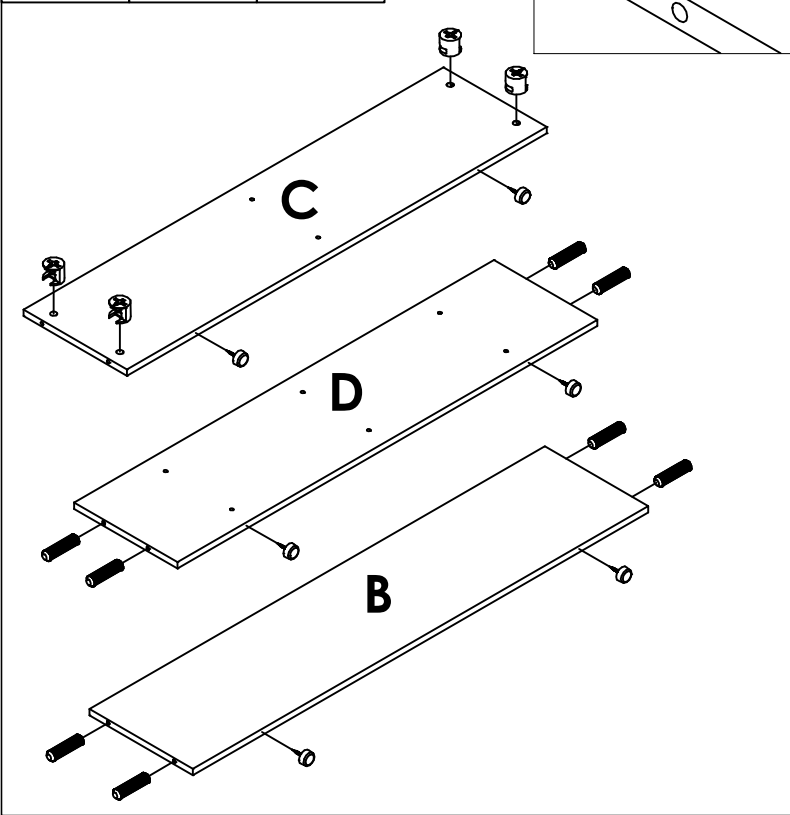
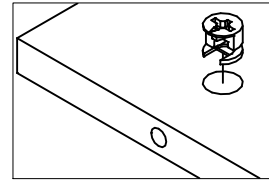
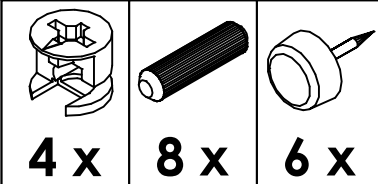

Étape / Step #4

NOTE: ASSUREZ VOUS QUE LES TROUS SONT LIBRES DE POUSSIÈRE / BE SURE THAT THE HOLES ARE FREE OF DUST

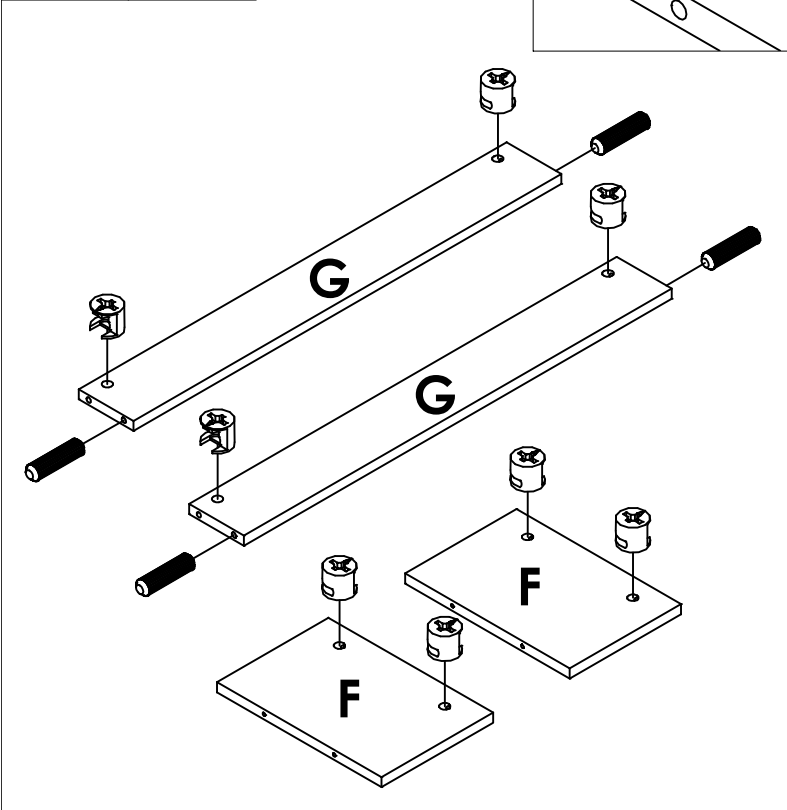
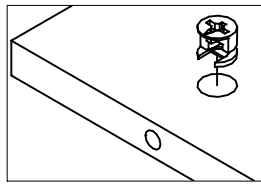
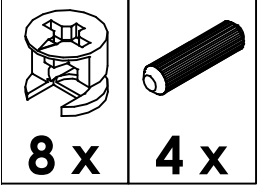

Étape / Step #5

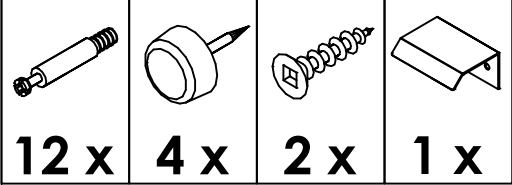

Installer sur le côté opposé des trous.  
Installed on the side opposite of holes.

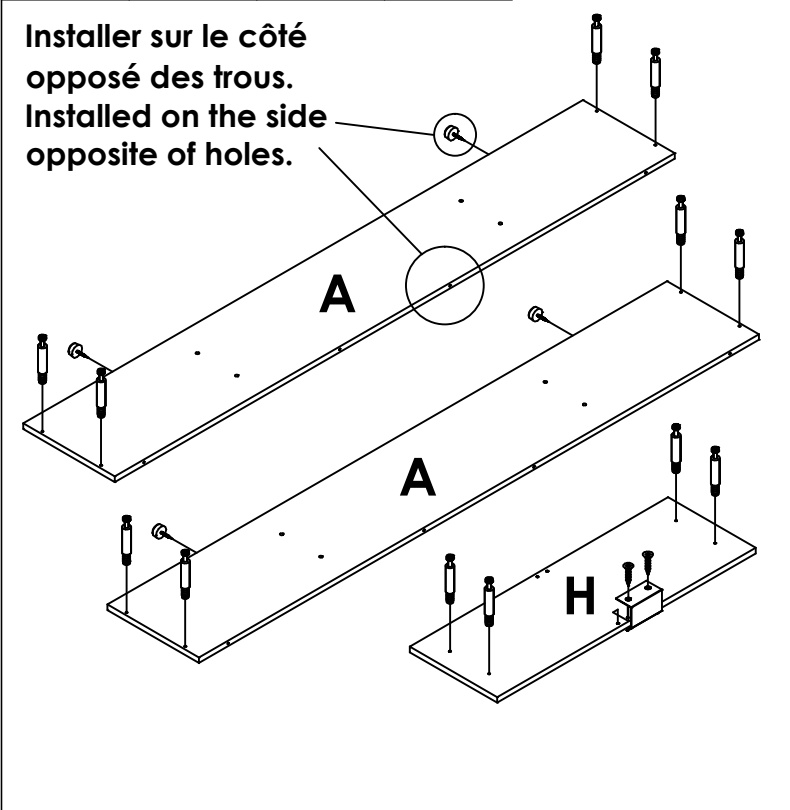

Étape / Step #6

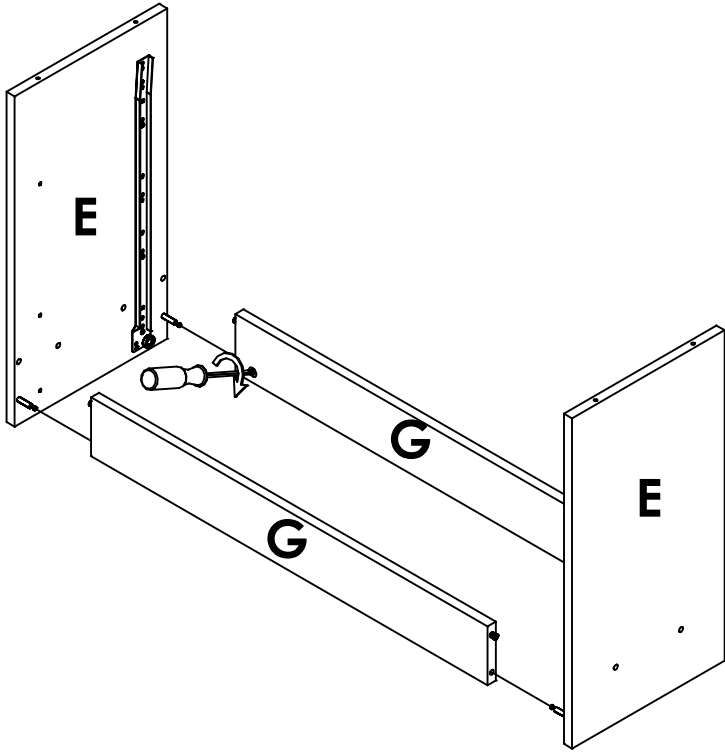

Étape / Step #7

3/4

#001  
4 x

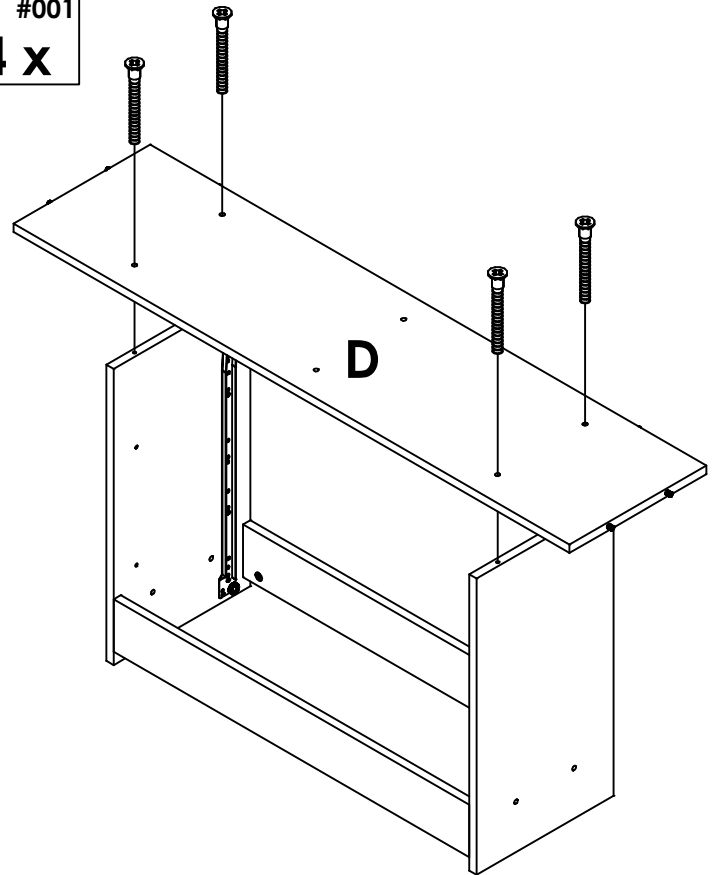

Étape / Step #8

#001  
4 x

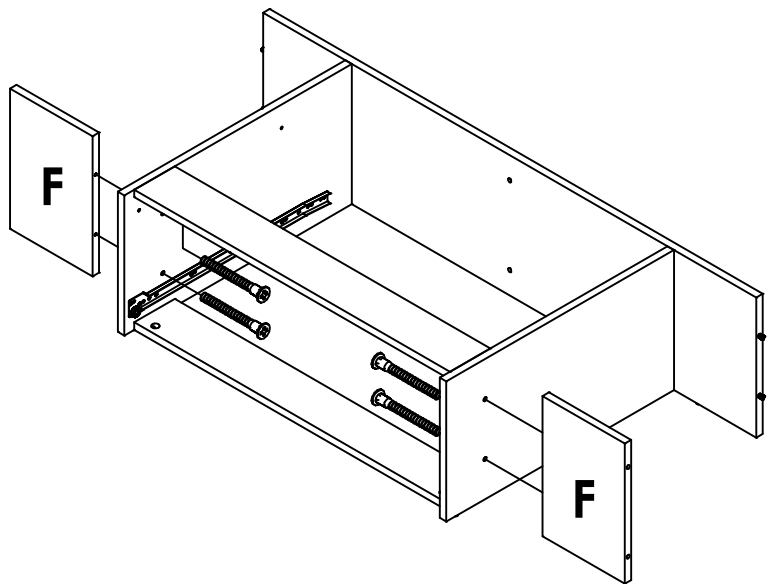

Étape / Step #9

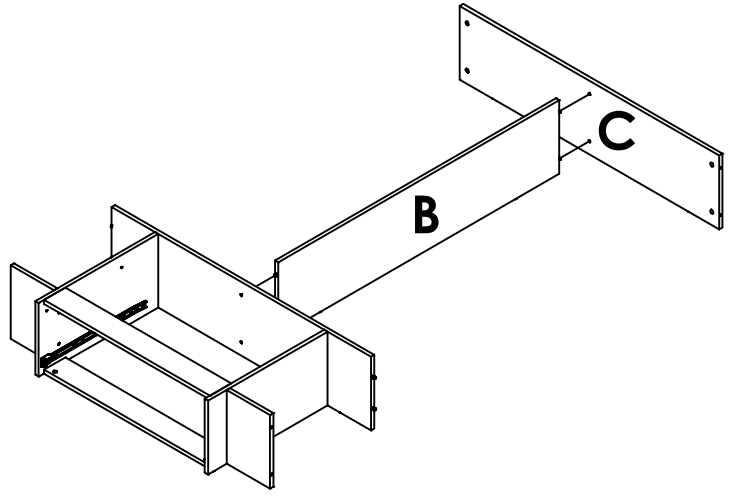

Étape / Step #10

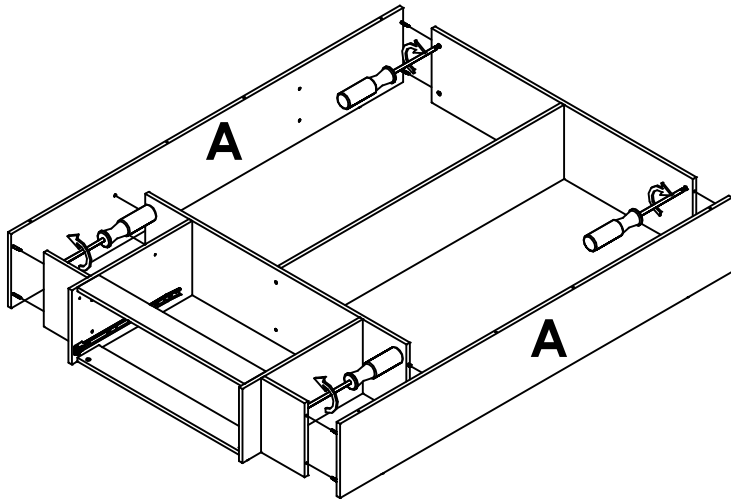

Étape / Step #11

4/4

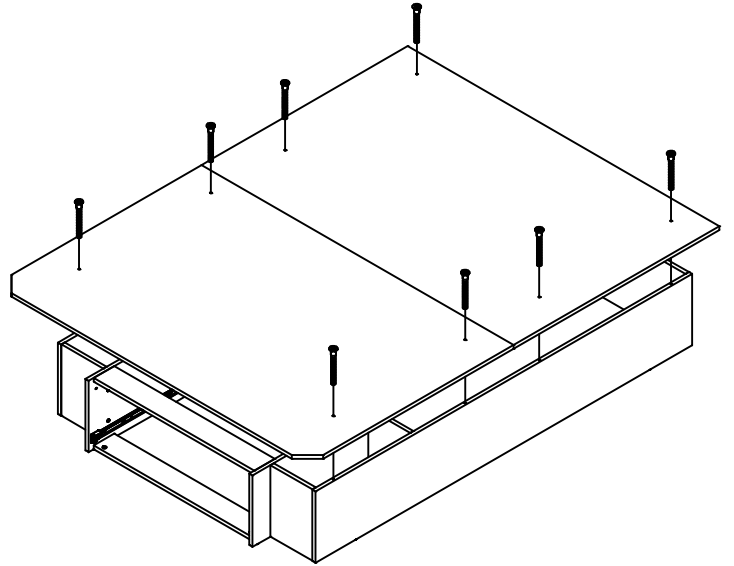

Étape / Step #12

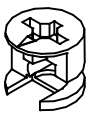

4 x

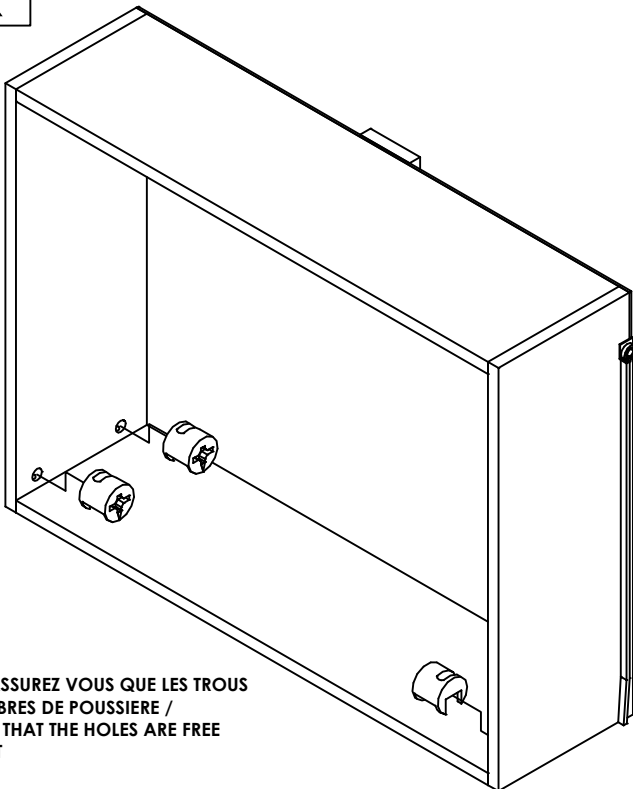

NOTE: ASSUREZ VOUS QUE LES TROUS  
SONT LIBRES DE POUSSIÈRE /  
BE SURE THAT THE HOLES ARE FREE  
OF DUST

Étape / Step #13

