

# ASSEMBLY INSTRUCTIONS

# MONTAGE INSTRUCTIONS

**Resin Series Outdoor Storage Shed • 4 x 2 Ft.**

**Abri de jardin en résine • 4 x 2 Pi.**

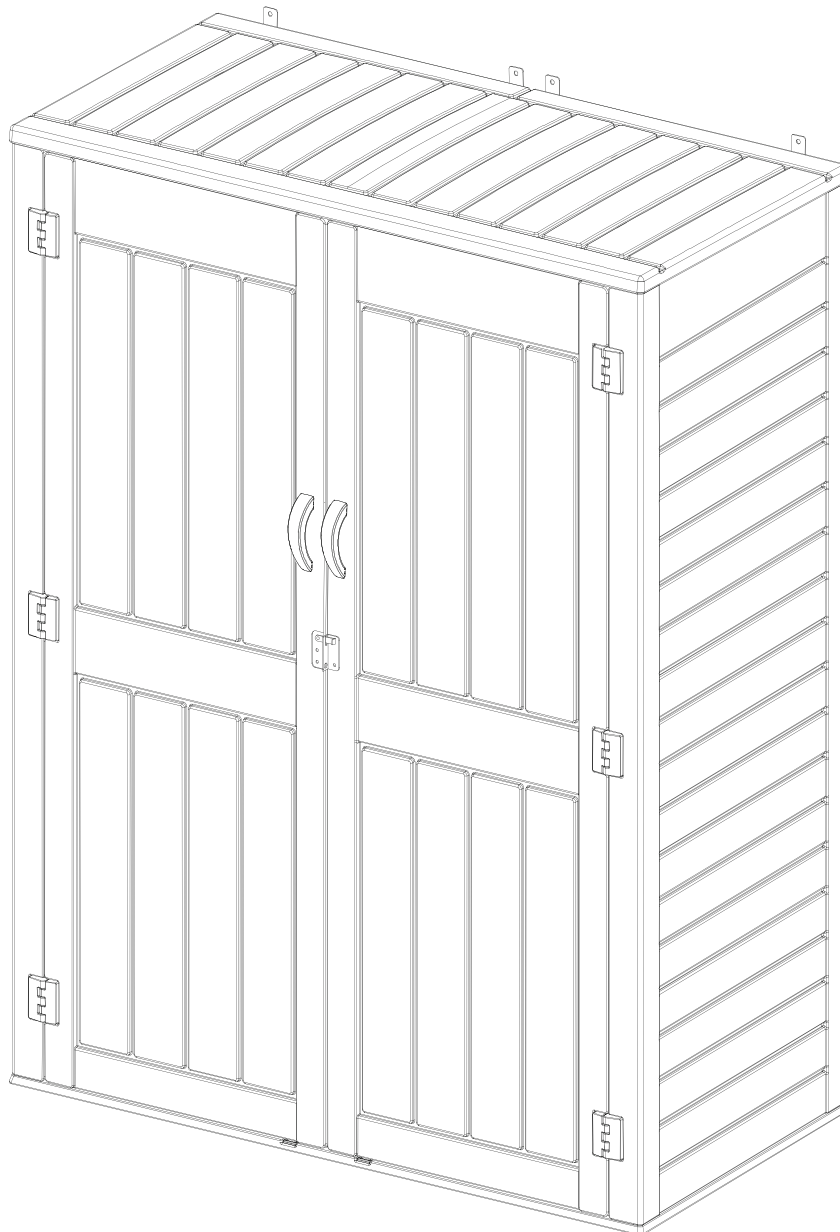



## Arrow Storage Products Limited Warranty Information

ShelterLogic Corp. warrants that our outdoor storage buildings will not fail due to perforation caused by rusting through the material. We will replace any part found to be perforated by rust under normal use, and service within that period. For your warranty to be in effect, the building must be maintained as directed in the owner's manual.

ShelterLogic Corp. warrants to the original owner that our outdoor storage products are free from defects in material and workmanship. ShelterLogic Corp. will send replacement parts free of charge found to be defective or missing.

### **The warranty period for this Arrow product is 2 years from date of purchase.**

This warranty only covers failures which occur during normal use. This warranty does not extend to color changes due to normal use, weathering or damage resulting from misuse or neglect, commercial use, failure to follow assembly instructions and/or the owner's manual (including but not limited to proper anchoring of a shed or building), painting, or forces of nature and other causes which are beyond the control of ShelterLogic Corp.'s control. Storage of pool chemicals and/or use of pressure-treated wood for the floor will cause steel corrosion and are not covered under warranty. The warranty is void if the product is modified in any way. In no event shall ShelterLogic Corp. be liable for incidental or consequential damages.

A purchase receipt or other proof of date of the original purchase will normally be required before warranty service is rendered. In no event will ShelterLogic Corp. pay for the cost of taking down the product, cost of flooring, construction labor, or any other related costs.

ShelterLogic Corp. reserves the right to request photographic proof of product defect to aid in determining extent of defect and aid in quality control efforts. ShelterLogic Corp. reserves the right to discontinue or change parts. If a part has been discontinued or is not available, ShelterLogic Corp. will substitute a part as may be compatible and available.

To file a claim, please visit: <https://www.shelterlogic.com/arrow-sheds/support/warranty/>

This warranty gives you specific legal rights, and you may also have other rights which vary from state to state / province to province.

## Informations sur la garantie limitée des produits de stockage Arrow

ShelterLogic Corp. garantit que ses abris de stockage extérieurs ne présenteront aucune défaillance due à une perforation due à la rouille. Nous remplacerons toute pièce perforée par la rouille dans des conditions normales d'utilisation et d'entretien pendant cette période. Pour que votre garantie soit valide, l'abri doit être entretenu conformément aux instructions du manuel du propriétaire.

ShelterLogic Corp. garantit au propriétaire initial que ses produits de rangement extérieurs sont exempts de défauts de matériaux et de fabrication. ShelterLogic Corp. enverra gratuitement les pièces de rechange jugées défectueuses ou manquantes.

### **La période de garantie pour ce produit Arrow est de 2 ans à compter de la date d'achat.**

Cette garantie ne couvre que les défaillances survenant lors d'une utilisation normale. Elle ne couvre pas les changements de couleur dus à une utilisation normale, aux intempéries ni les dommages résultant d'une mauvaise utilisation ou d'une négligence, d'un usage commercial, du non-respect des instructions de montage et/ou du manuel d'utilisation (y compris, mais sans s'y limiter, l'ancrage correct d'un abri ou d'un bâtiment), de la peinture, des forces de la nature et autres causes indépendantes de la volonté de ShelterLogic Corp. L'entreposage de produits chimiques pour piscine et/ou l'utilisation de bois traité sous pression pour le plancher causent la corrosion de l'acier et ne sont pas couverts par la garantie. La garantie est annulée en cas de modification du produit, de quelque manière que ce soit. ShelterLogic Corp. ne peut en aucun cas être tenue responsable des dommages accessoires ou indirects.

Un reçu d'achat ou une autre preuve d'achat originale sera généralement exigé avant toute intervention sous garantie. ShelterLogic Corp. ne prendra en charge en aucun cas les frais de démontage du produit, de revêtement de sol, de main-d'œuvre ou tout autre coût connexe.

ShelterLogic Corp. se réserve le droit de demander une preuve photographique du défaut du produit afin d'en déterminer l'étendue et de faciliter le contrôle de la qualité. ShelterLogic Corp. se réserve le droit d'interrompre la production ou de remplacer des pièces. Si une pièce est interrompue ou indisponible, ShelterLogic Corp. la remplacera par une pièce compatible et disponible.

Pour déposer une réclamation, veuillez visiter : <https://www.shelterlogic.com/arrow-sheds/support/warranty/>

Cette garantie vous confère des droits légaux spécifiques, et vous pouvez également avoir d'autres droits qui varient d'une province à l'autre / d'une province à l'autre.

**SHELTERLOGIC**  
GROUP

1101 N. Fourth St. • Breese, IL • P 618.526.4546 • F 618.526.0017

# CARE AND SAFETY GUIDELINES

# SOINS ET SÉCURITÉ INSTRUCTIONS

- This shed is intended for storage purposes only. It is not designed for habitation.
- It is strongly recommended to secure the shed to an immovable object or anchor to the ground by drilling holes in the shed floor (at the instructed locations) and inserting proper screws into the ground.
- Do not attempt assembly on windy nor cold days.
- Periodically check the shed to ensure that it is stable and that the site is level.
- Use caution when handling parts with steel edges.
- When assembling or handling the shed, use only those tools listed in this user manual.
- Always wear protective safety equipment including long sleeves when assembling or performing any maintenance on your shed.
- Avoid using a lawnmower or mechanical scythe near the shed.
- Wear safety goggles and always follow the manufacturer's instructions when using power tools.
- Wash the shed with a garden hose and a mild detergent solution. Do not use a metal brush nor abrasive cleaners, including degreasers and oil- or acetone-based cleaning materials, as these may stain or damage the shed.
- Do not store hot items, such as recently-used grills and blowtorches.
- Do not store volatile chemicals in the shed.
- Avoid placing heavy items against the walls, as this may cause distortion.
- Keep the roof clear of accumulated snow and leaves. Large amounts of snow or debris on the roof can damage the shed and make it unsafe to enter.
- Wind direction is an important factor to consider when determining the location of the shed. Reduce exposure to the wind, on the door side in particular. Keep doors closed and locked when the shed is not in use to prevent damage.
- Do not stand on the roof.
- Consult your local authorities to check if permits are required to erect the shed.

- Cet abri est destiné uniquement au rangement. Il n'est pas conçu pour l'habitation.
- Il est fortement recommandé de fixer l'abri à un point fixe ou de l'ancrer au sol en perçant des trous dans le plancher (aux endroits indiqués) et en insérant des vis appropriées dans le sol.
- N'essayez pas le montage par temps venteux ou froid.
- Vérifiez régulièrement la stabilité de l'abri et la planéité du terrain.
- Manipulez avec précaution les pièces aux rebords métalliques.
- Pour le montage ou la manipulation de l'abri, utilisez uniquement les outils mentionnés dans ce manuel d'utilisation.
- Portez toujours de l'équipement de protection individuelle, notamment des manches longues, lors du montage ou de l'entretien de votre abri.
- Évitez d'utiliser une tondeuse à gazon ou une débroussailleuse à proximité de l'abri.
- Portez des lunettes de sécurité et suivez toujours les instructions du fabricant lors de l'utilisation d'outils électriques.
- Nettoyez l'abri avec un boyau d'arrosage et une solution détergente douce. N'utilisez pas de brosse métallique ni de nettoyeurs abrasifs, y compris les dégraissants et les produits de nettoyage à base d'huile ou d'acétone, car ils pourraient tacher ou endommager l'abri.
- Ne rangez pas d'articles chauds, comme des barbecues ou des chalumeaux récemment utilisés.
- N'entreposez pas de produits chimiques volatils dans l'abri.
- Évitez de placer des objets lourds contre les parois, car cela pourrait les déformer.
- Retirez le toit de la neige et des feuilles accumulées. Une accumulation importante de neige ou de débris sur le toit peut endommager l'abri et le rendre dangereux à utiliser.
- La direction du vent est un facteur important à considérer pour choisir l'emplacement de l'abri. Réduisez l'exposition au vent, surtout du côté de la porte. Gardez les portes fermées et verrouillées lorsque l'abri n'est pas utilisé afin d'éviter tout dommage.
- Ne vous tenez pas sur le toit.
- Informez-vous auprès de votre municipalité pour savoir si des permis sont nécessaires pour installer l'abri.

# Assembly Preparation

# Préparation de l'assemblage

## 1. Site preparation

Leveling the ground.

## Préparation du site

Nivellement du terrain.



## 2. Leave enough space

Give yourself plenty of room to build and leave space around the shed.

## Laissez suffisamment d'espace

Prévoyez suffisamment d'espace pour construire et laissez de la place autour du cabanon de jardin.

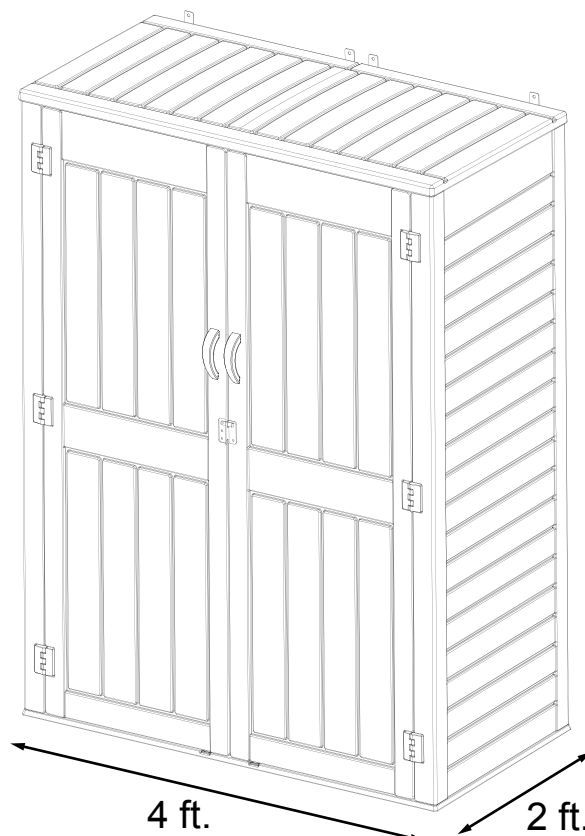

## REQUIRED TOOLS • OUTILS REQUIS

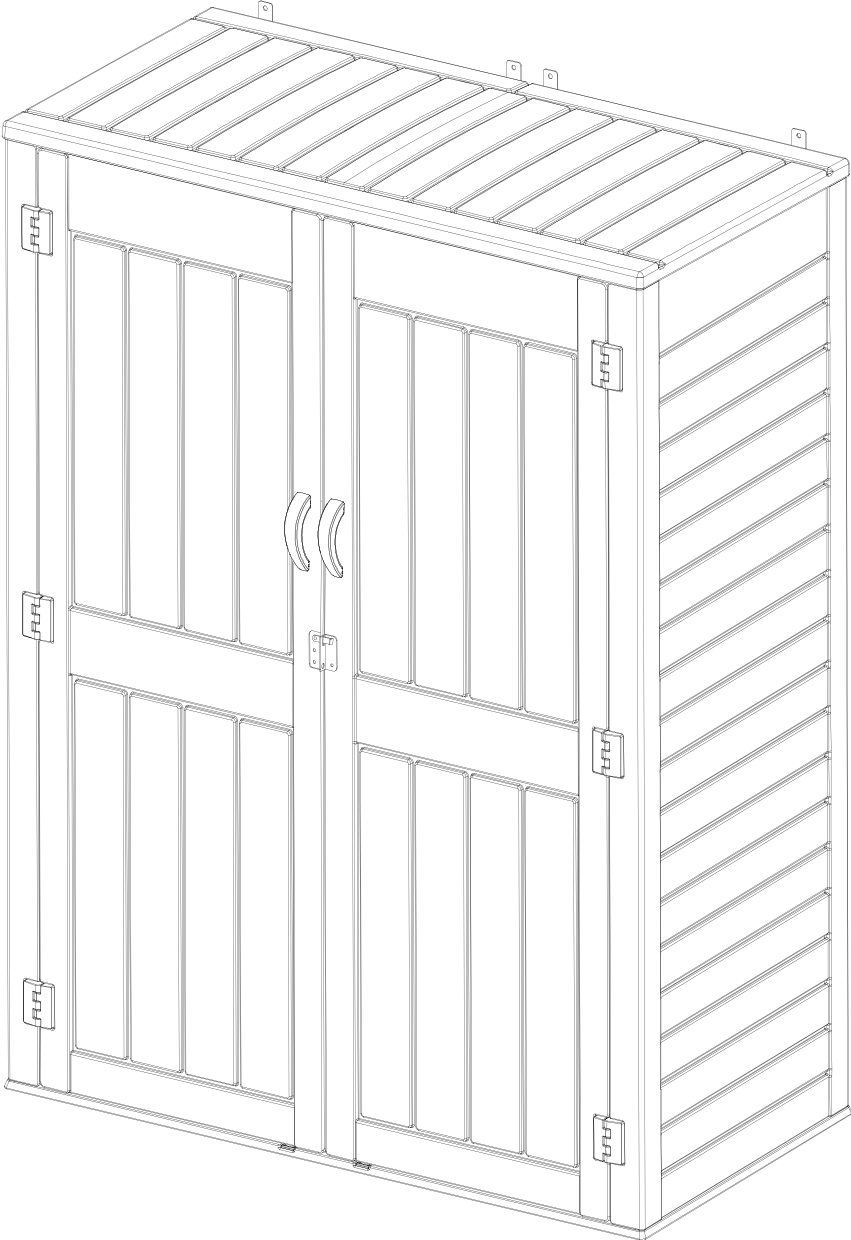
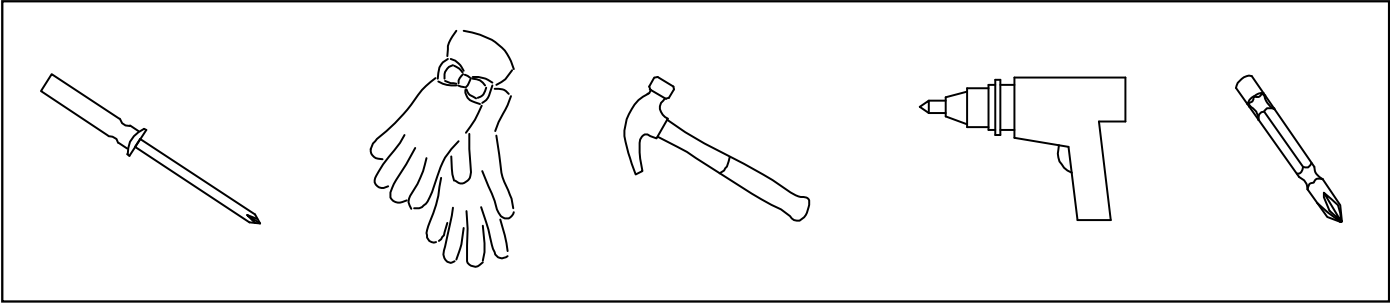











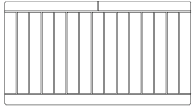





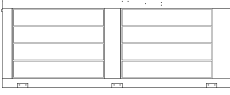

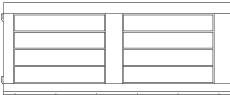

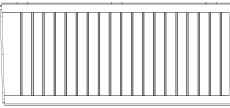
# Accessories & Parts

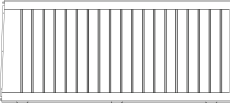
## Accessoires et pièces

**! IMPORTANT, RETAIN FOR FUTURE REFERENCE: READ CAREFULLY**  
**! IMPORTANT, À CONSERVER POUR LA CONSULTATION ULTÉRIEURE : LIRE ATTENTIVEMENT**

1. Organize and check all required parts before assembling.
2. Assemble shed on a base on a flat, level surface.
3. Two or more people will be needed for assembly.

1. Organisez et vérifiez toutes les pièces nécessaires avant l'assemblage.
2. Assemblez l'abri sur une base posée sur une surface plane et de niveau.
3. Deux personnes ou plus seront nécessaires pour l'assemblage.

| Item No.<br>No. d'article | Reference Image<br>Image de référence   | Qty.<br>Qté. | Item No.<br>No. d'article | Reference Image<br>Image de référence  | Qty.<br>Qté. |
|---------------------------|---|--------------|---------------------------|--|--------------|
| <b>A</b>                  |    | X1           | <b>1</b>                  |               | X1           |
| <b>B</b>                  |    | X1           | <b>2</b>                  |               | X12          |
| <b>C</b>                  |  | X1           | <b>3</b>                  |               | X4           |
| <b>D</b>                  |  | X1           | <b>4</b>                  |             | X6           |
| <b>E</b>                  |  | X2           | <b>5</b>                  |             | X12          |
| <b>G</b>                  |  | X1           | <b>6</b>                  |             | X2           |
| <b>H</b>                  |  | X1           | <b>7</b>                  | <br>M4x30mm | X2           |
| <b>GB</b>                 |  | X2           | <b>8</b>                  | <br>M4x40mm | X4           |
|                           |   |              | <b>9</b>                  |             | X4           |
|                           |   |              | <b>10</b>                 | <br>M5x16mm | X76          |
|                           |   |              | <b>11</b>                 | <br>M6x16mm | X40          |
|                           |   |              | <b>12</b>                 | <br>M4x20mm | X16          |
|                           |   |              | <b>13</b>                 | <br>M6x25mm | X4           |

**1**

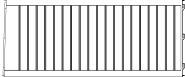
|   |   |
|---|---|
|  |  |
| <b>ⓑ</b> 1pc  | <b>ⓓ</b> 1pc  |

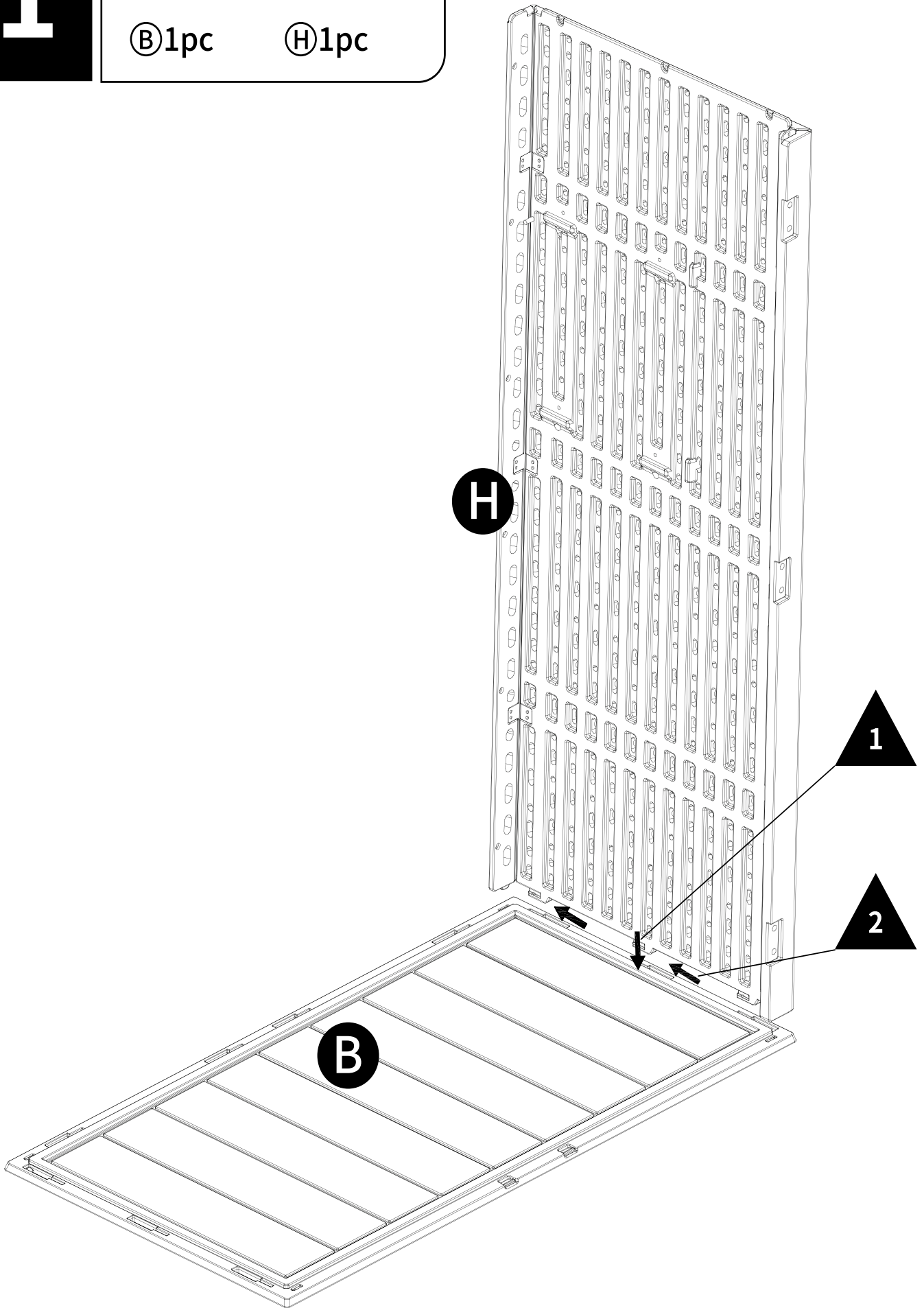

2

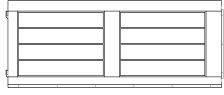

ⓔ 1pc

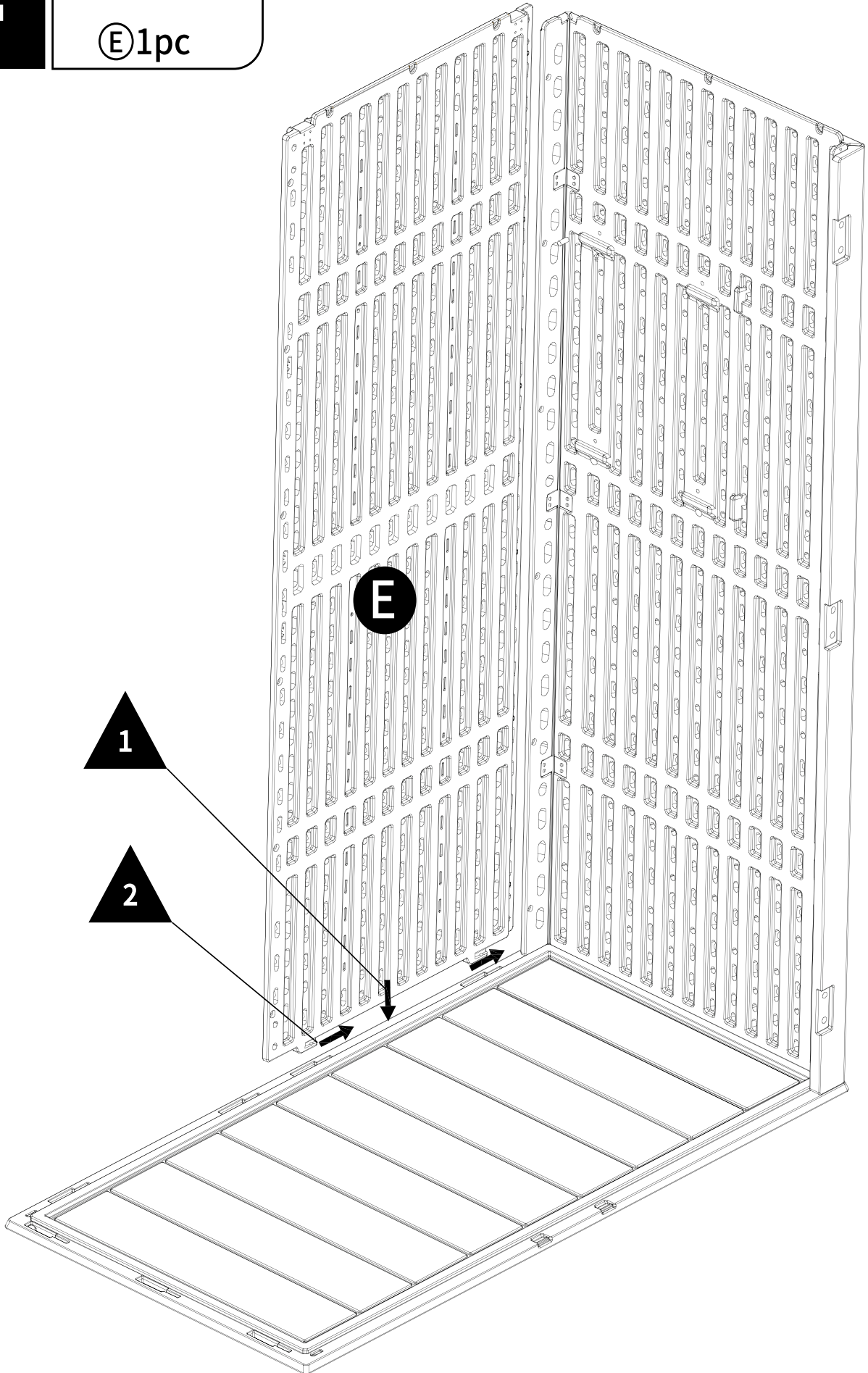

3

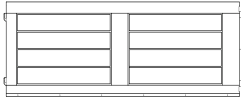

ⓔ 1pc

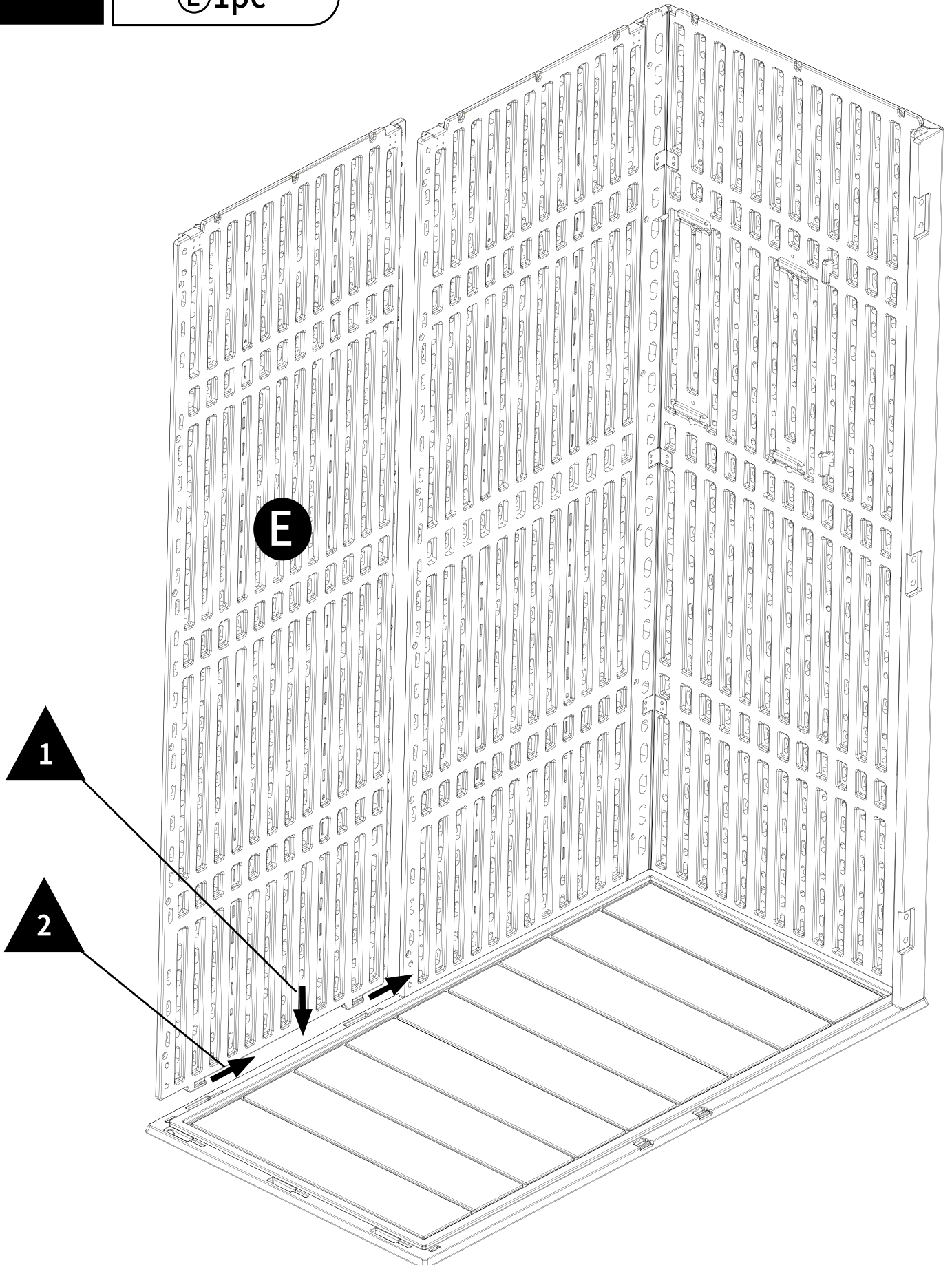

**4**

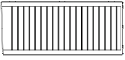

Ⓒ1pc

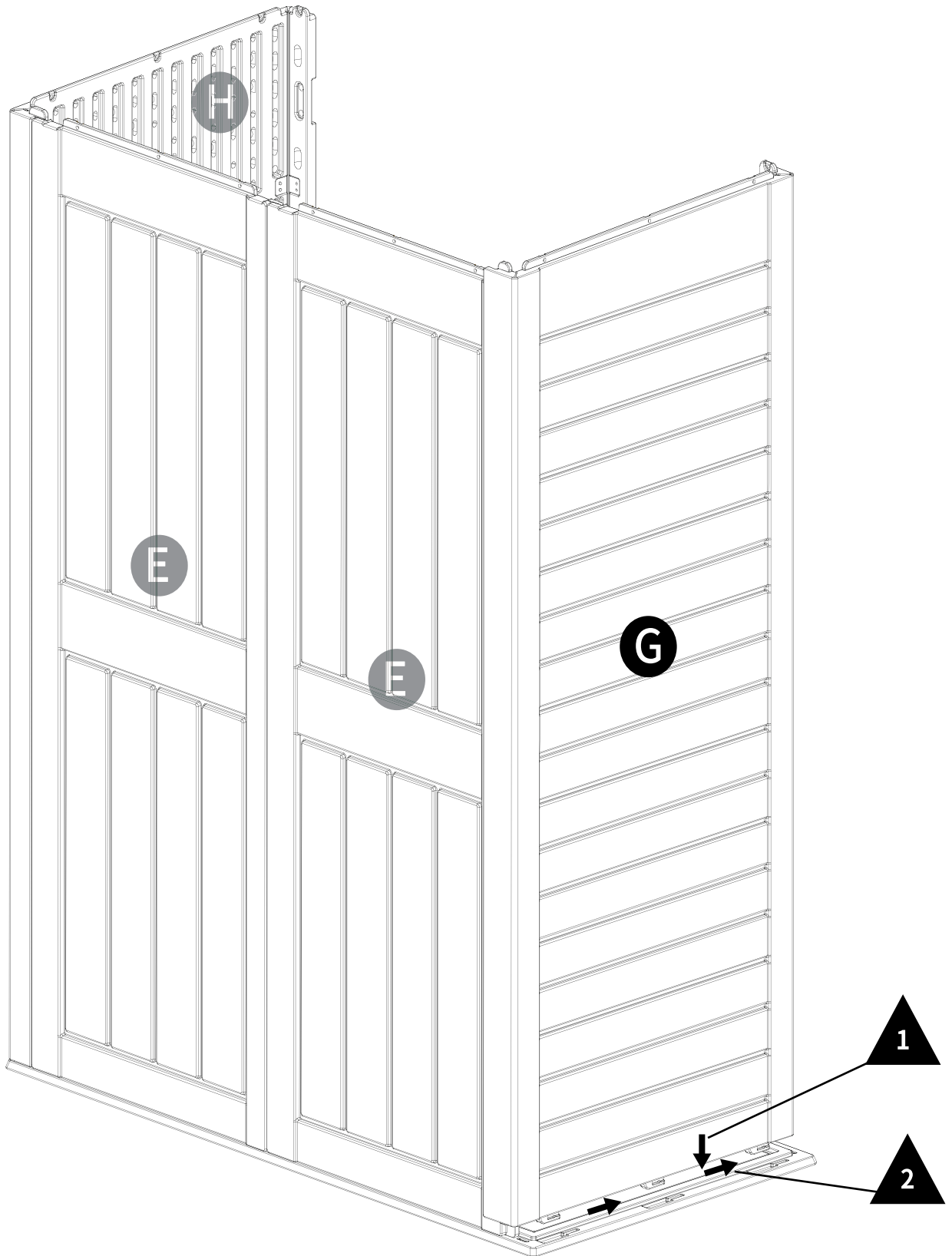

5



⑪ 18pcs

11

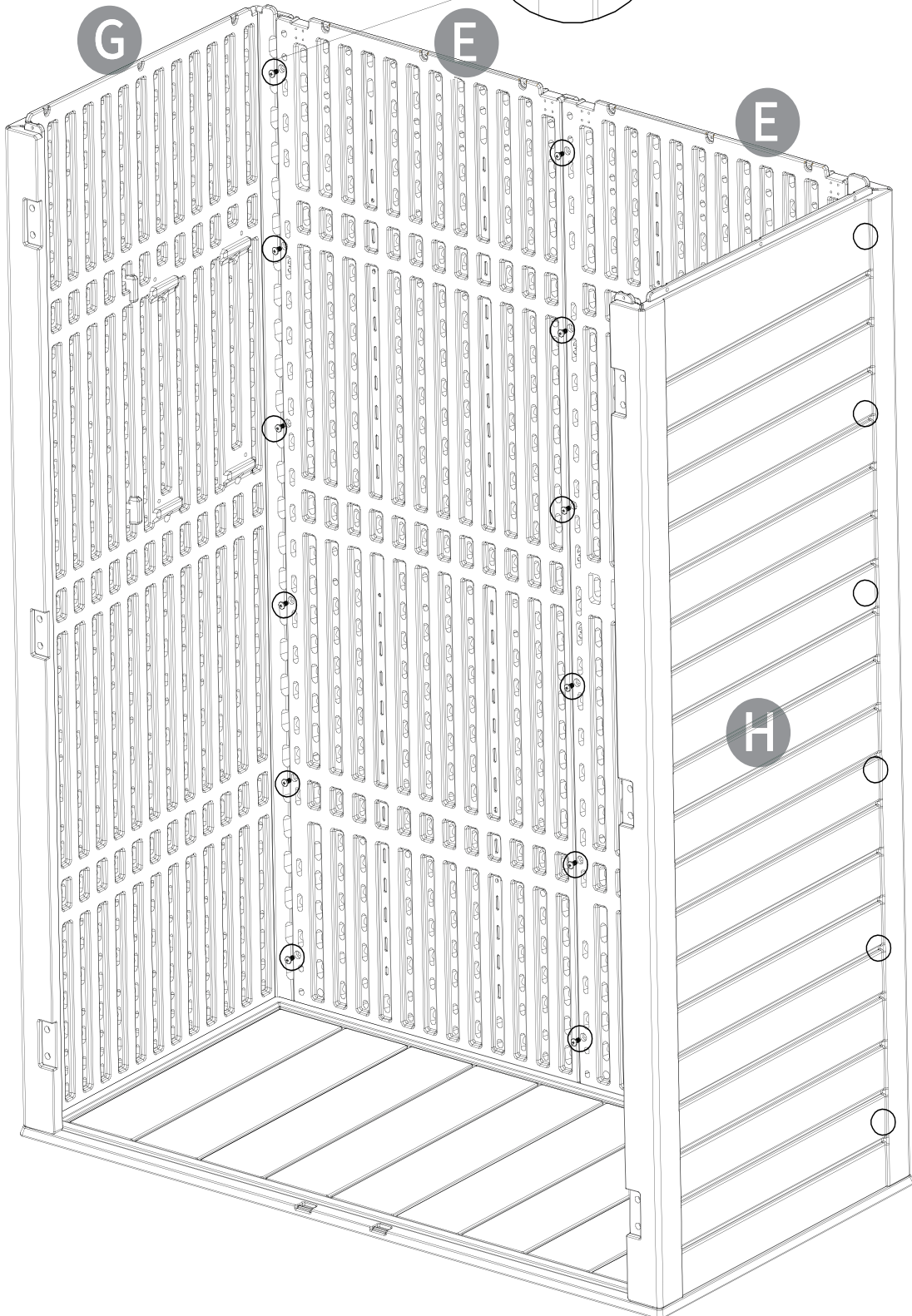
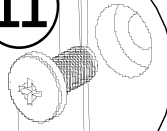

6



③ 4 pcs



⑫ 16 pcs

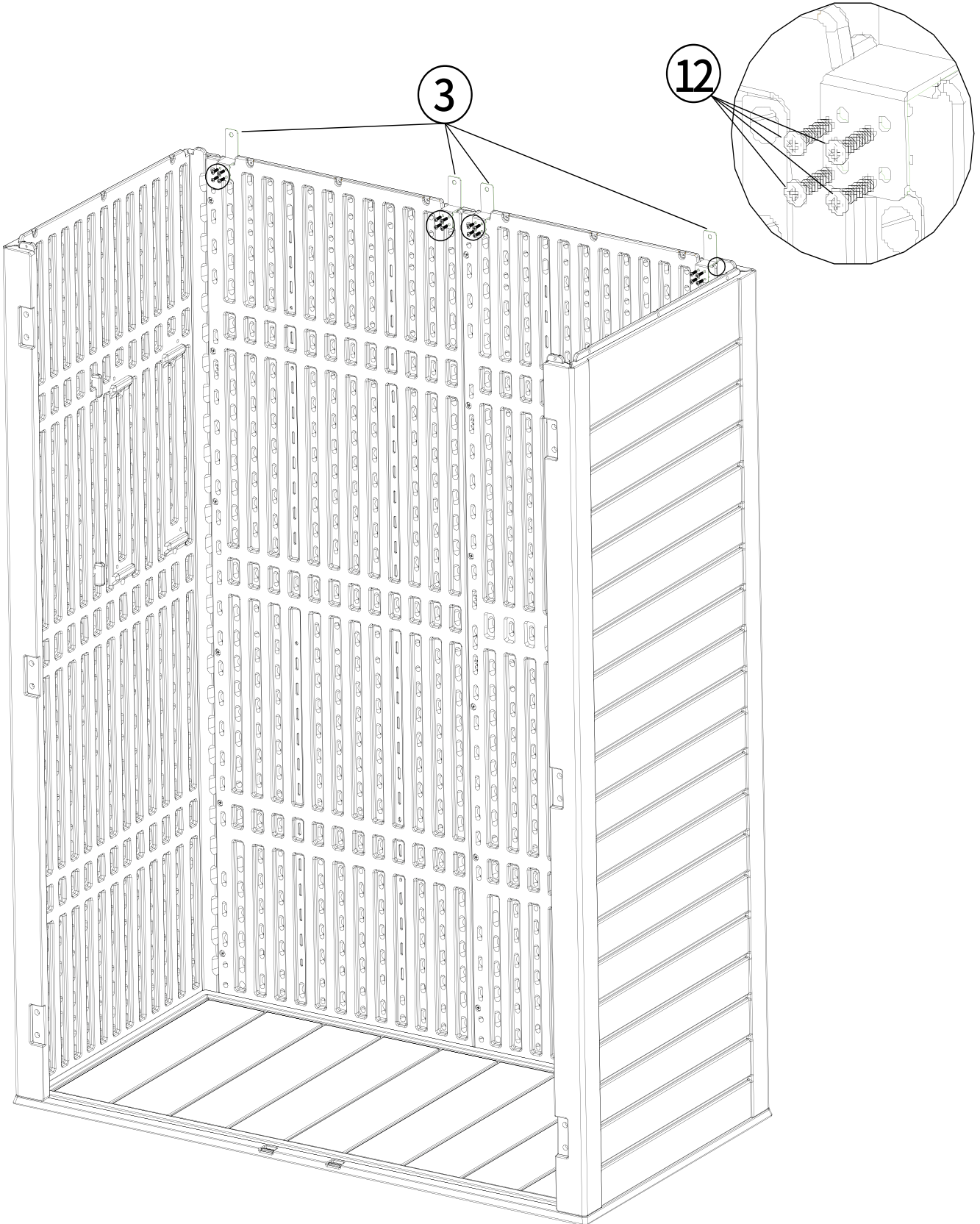

7

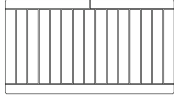

Ⓐ 1pc

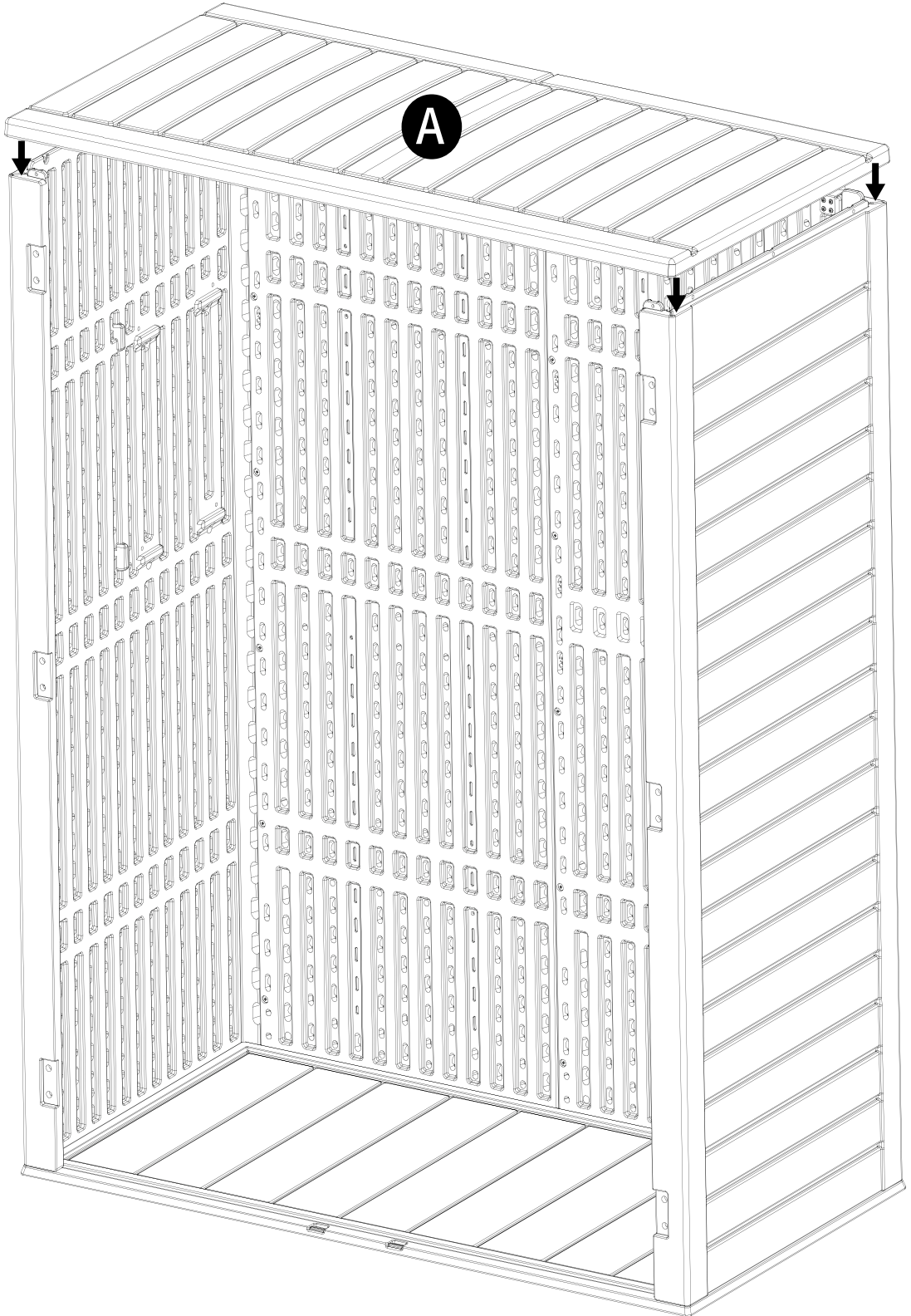

8

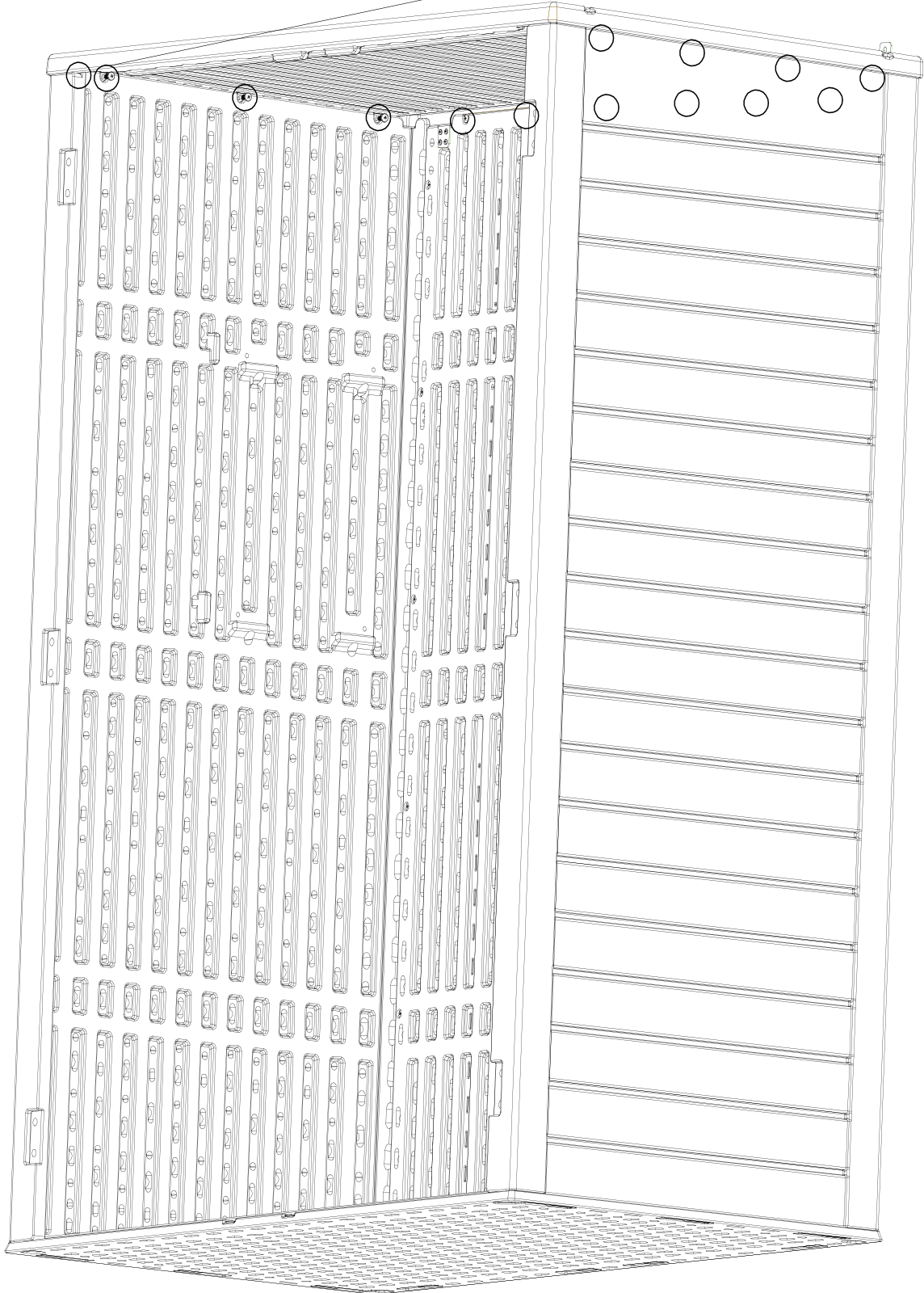
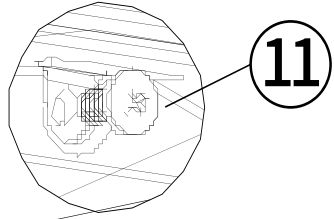
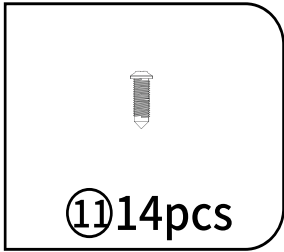

# 9

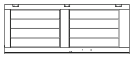

© 1pc ① 1pc ② 3pcs ④ 3pcs ⑥ 1pc ⑦ 1pc ⑧ 2pcs ⑩ 8pcs

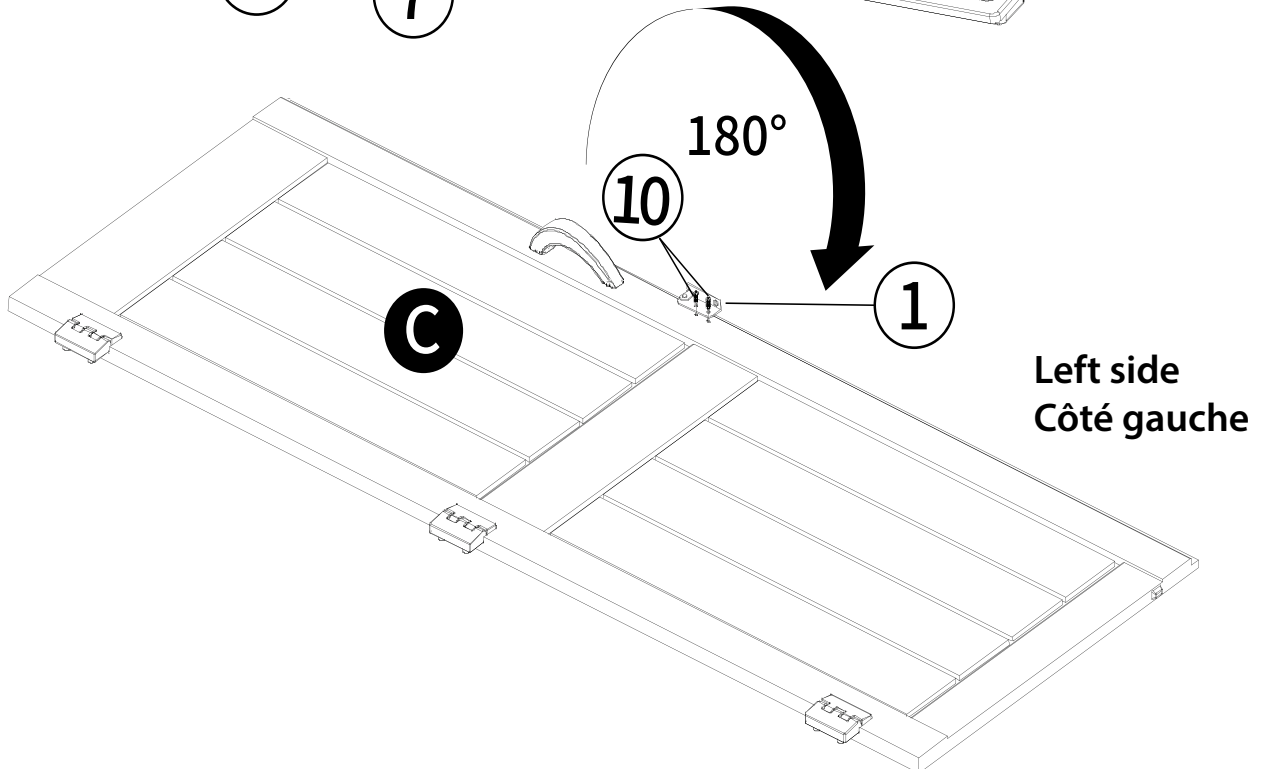
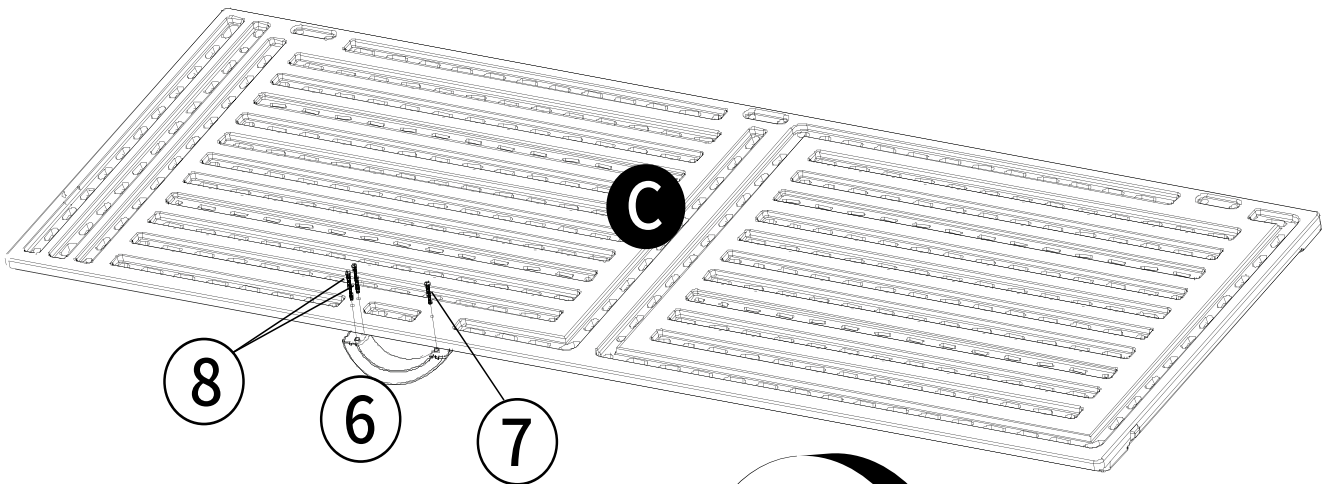
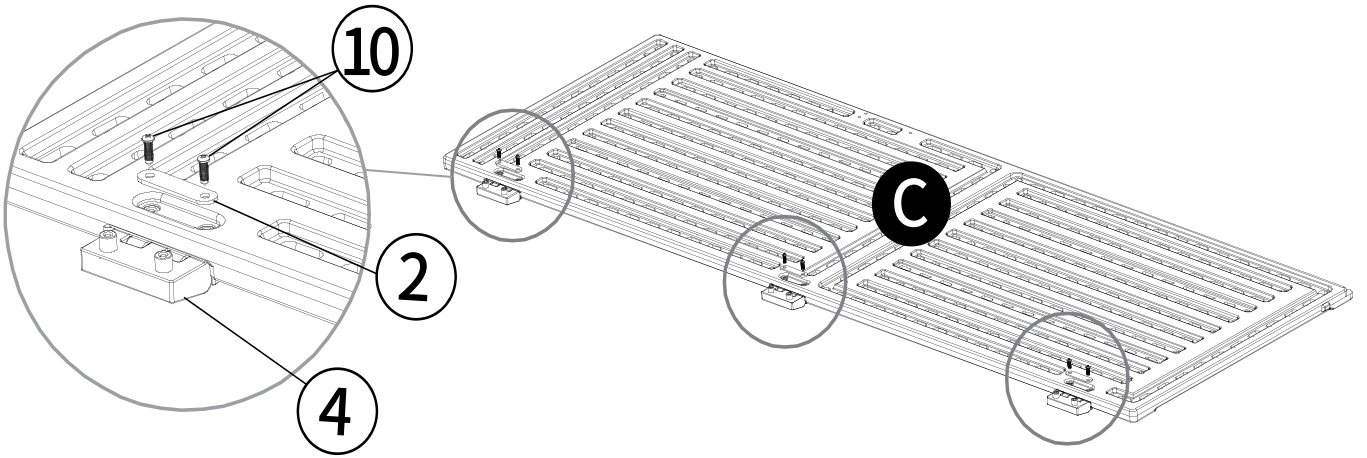

# 10

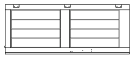

⑩ 1pc



④ 3pcs



② 3pcs



⑥ 1pc



⑦ 1pc



⑧ 2pcs



⑩ 8pcs

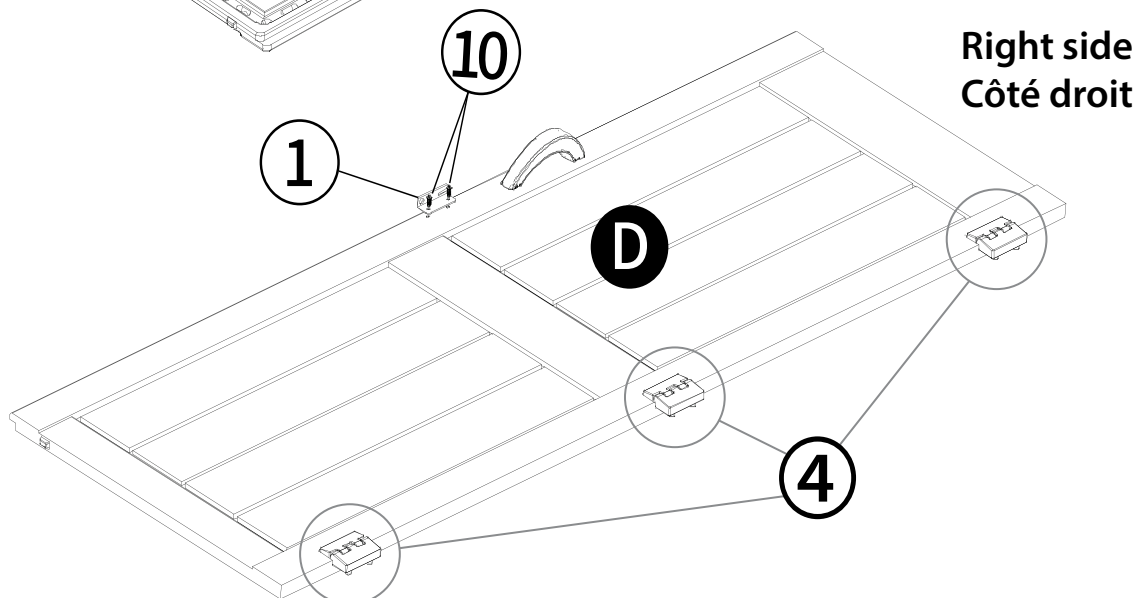
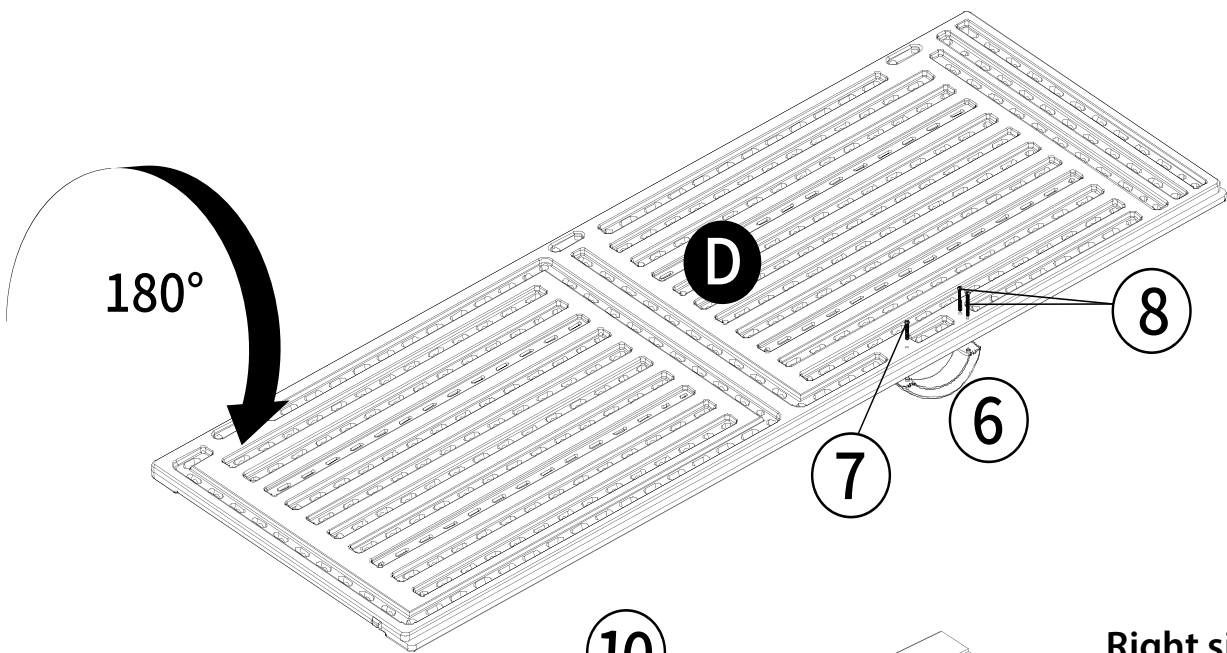
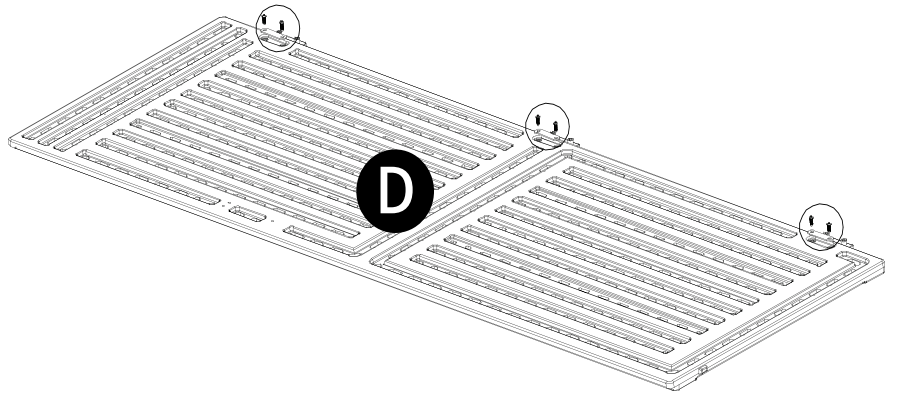
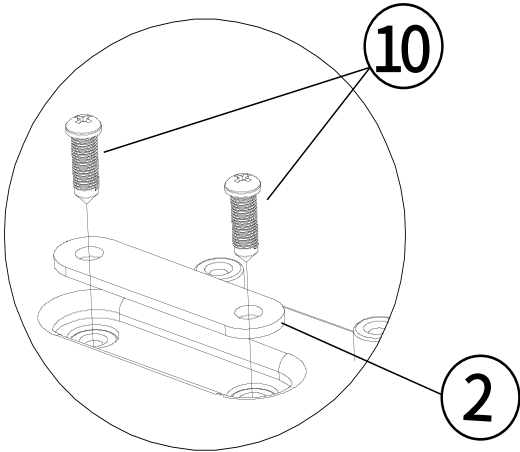

# 11

②3pcs    ⑩6pcs

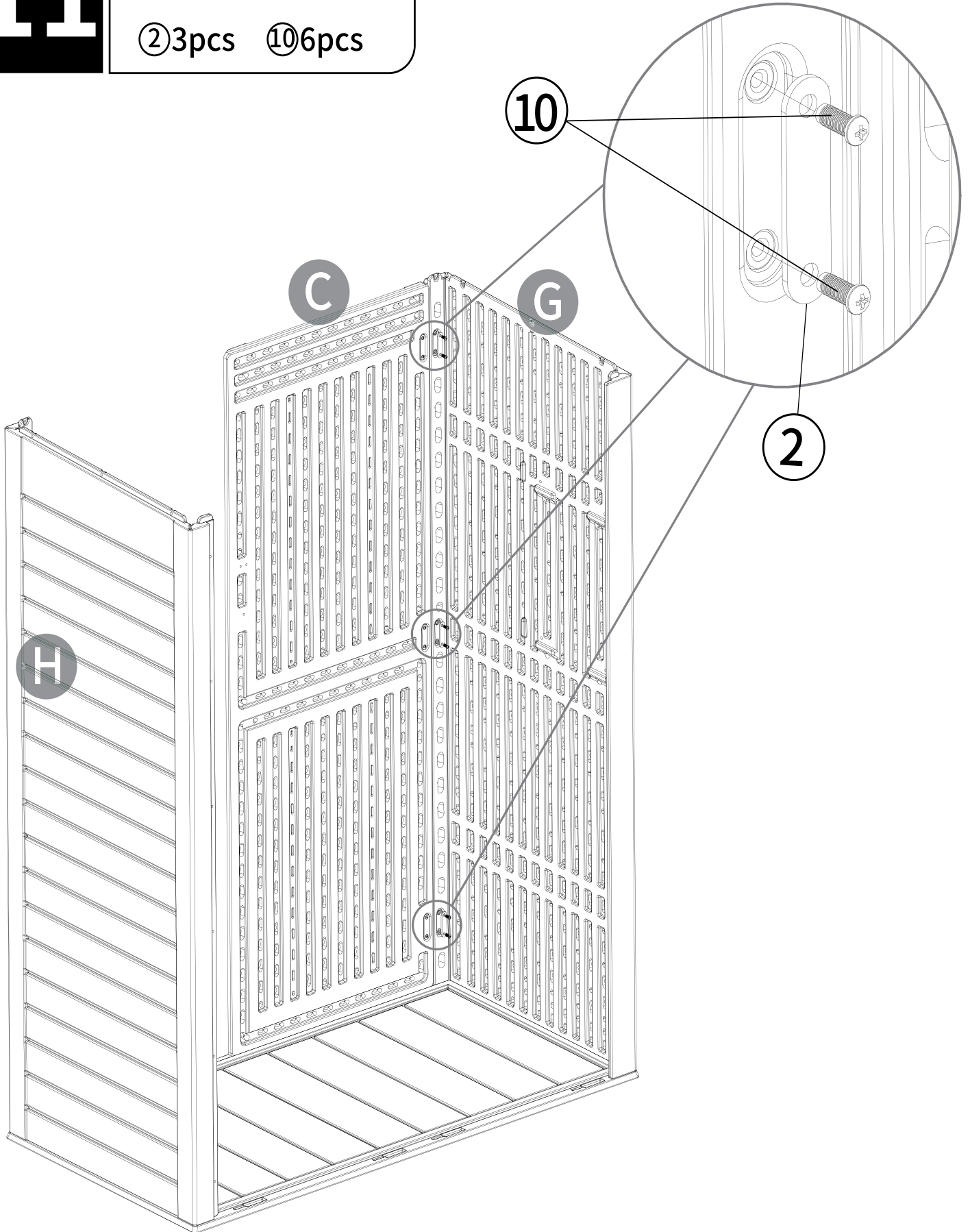

# 12



② 3pcs



⑩ 6pcs

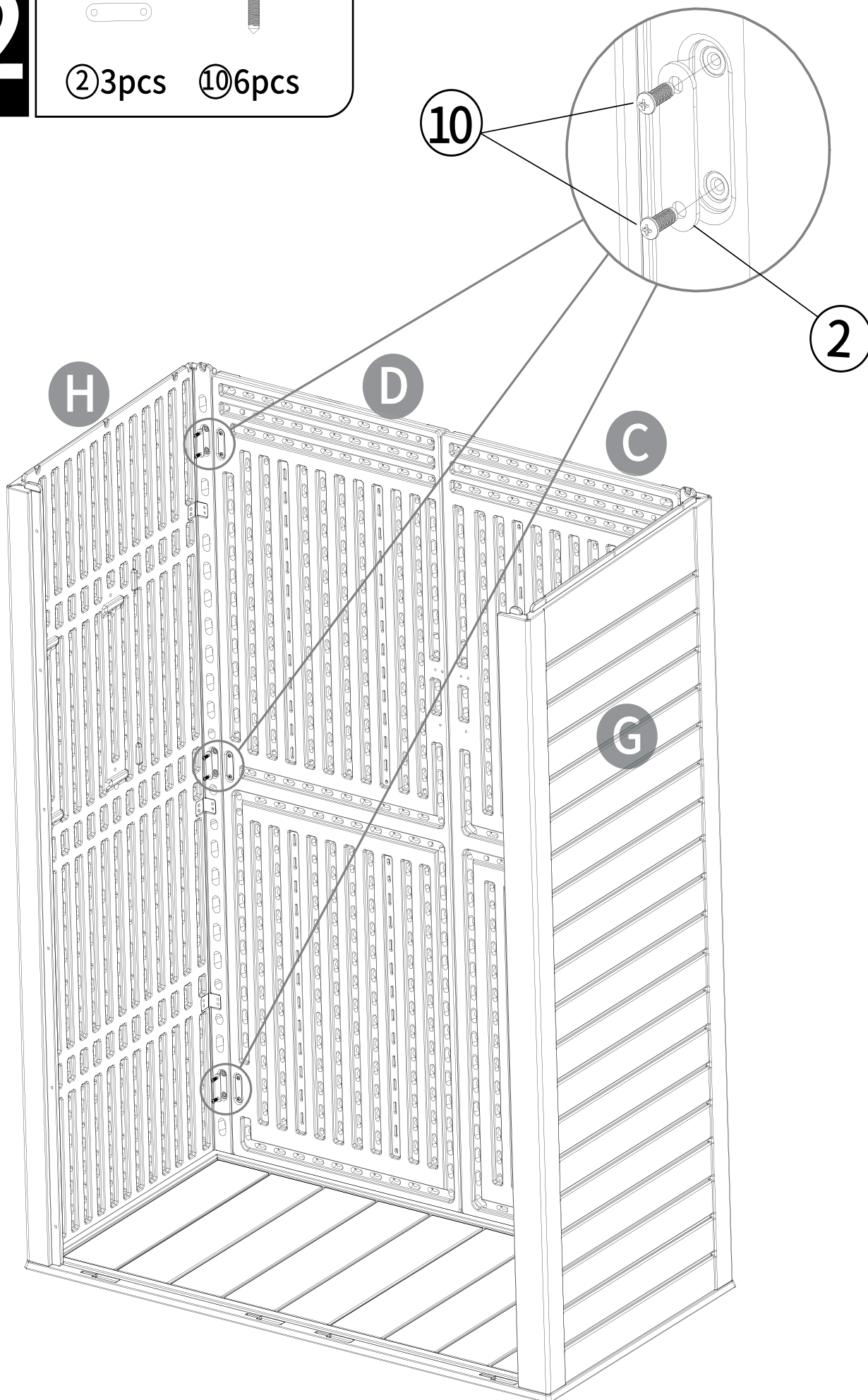

# 13



⑤ 12pcs ⑩ 48pcs

5

x12

10

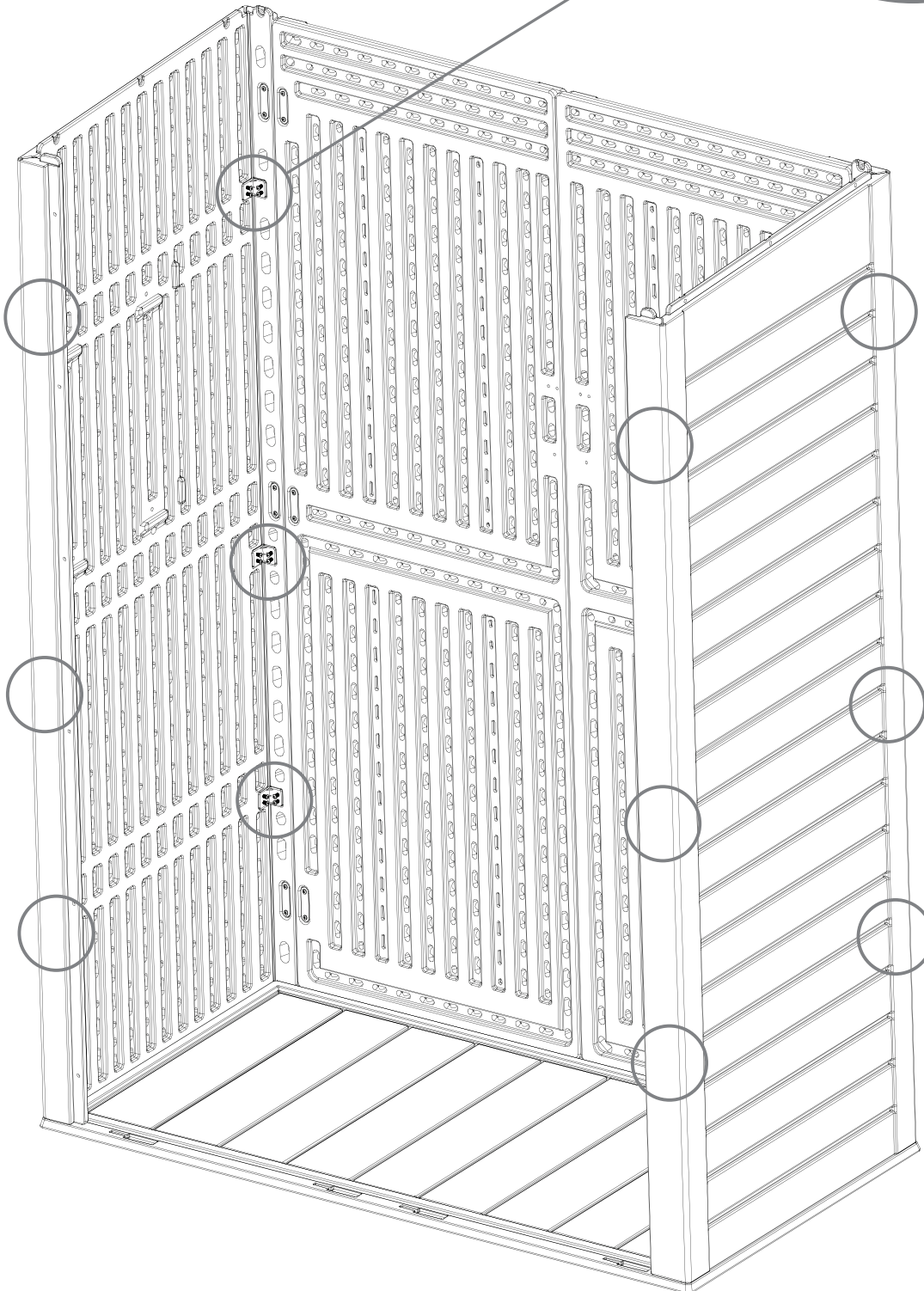

# 14



⑨4pcs    ⑬4pcs

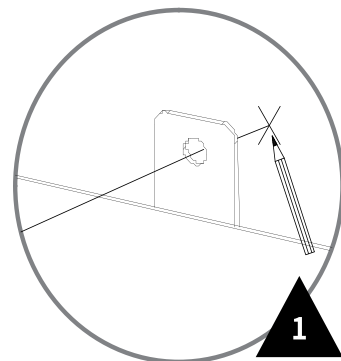

1

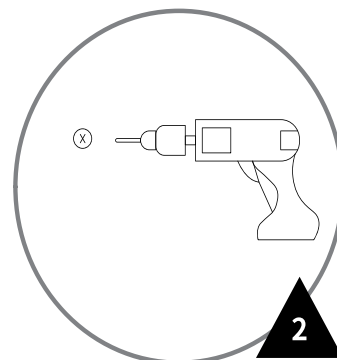

2

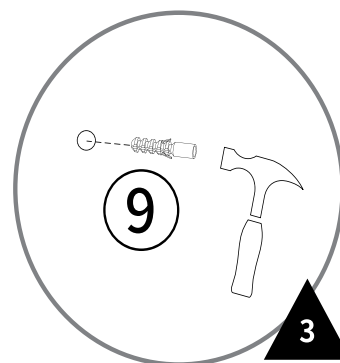

9

3

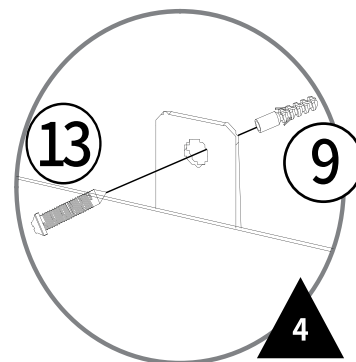

13

9

4

15



GB 2pcs 11 8pcs

GB

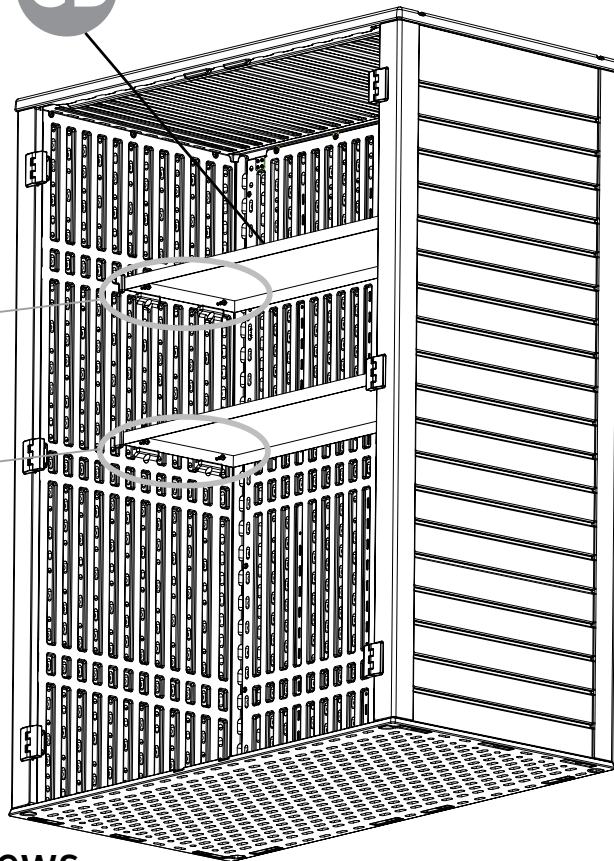

11

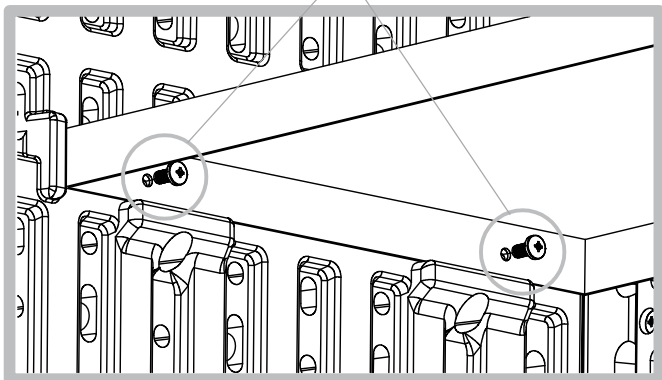

Affix the shelves with screws  
Fixez les tablettes avec des vis.

GB

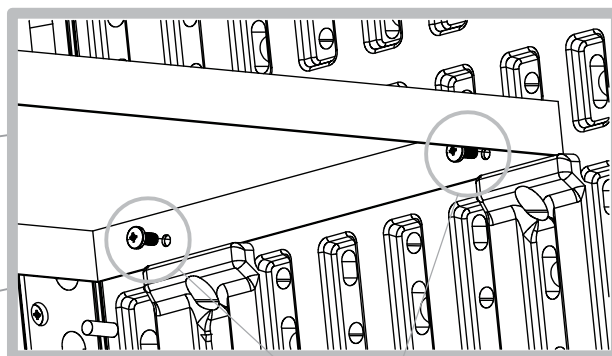
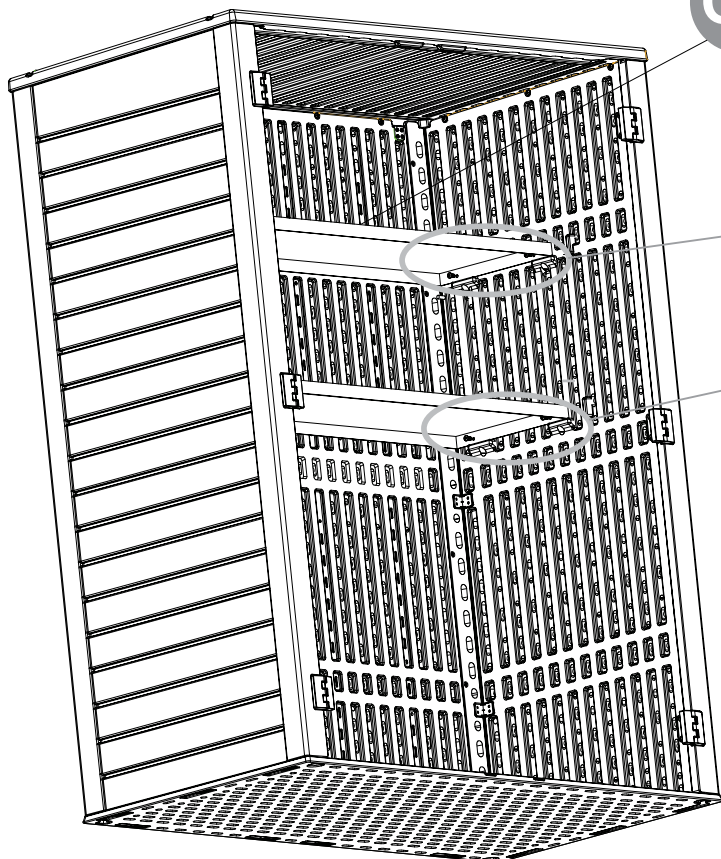

11

16



Installation Completed

Installation terminée